

FEAL

FEAL d.o.o za preradu aluminija-Široki Brijeg, Trnska cesta 146

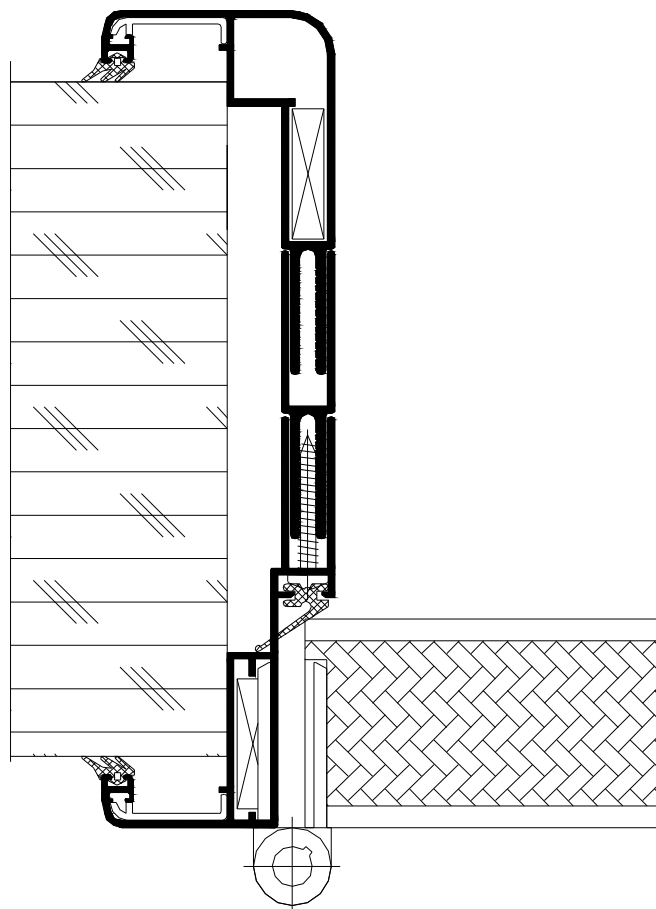



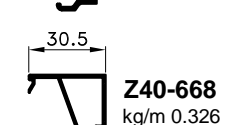
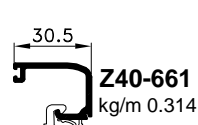
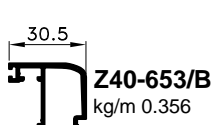
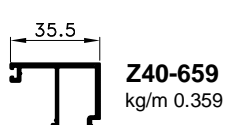
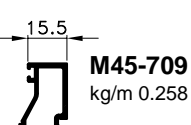
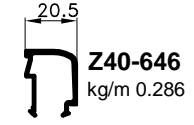
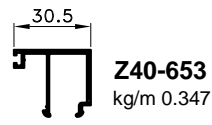
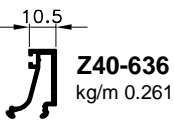
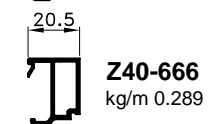
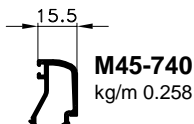
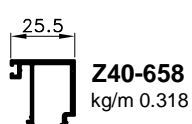
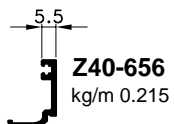
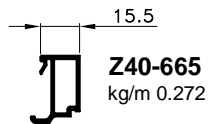
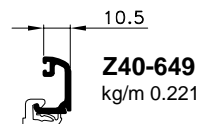
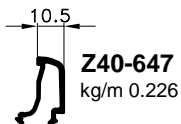
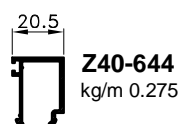
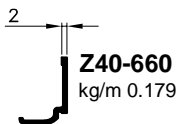
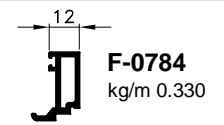
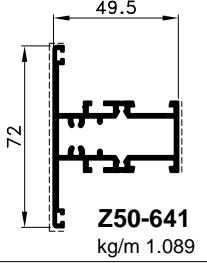
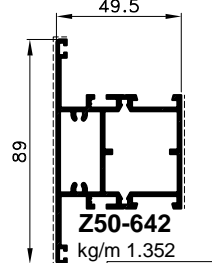
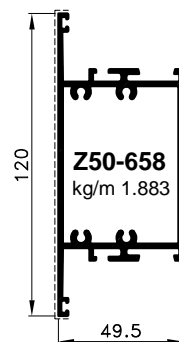
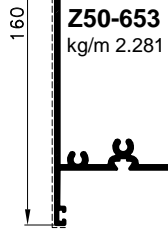
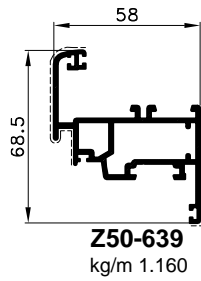
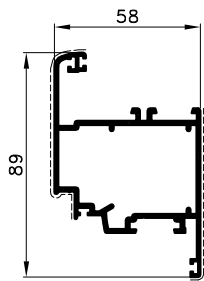
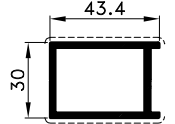
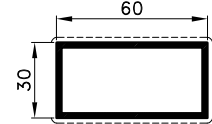
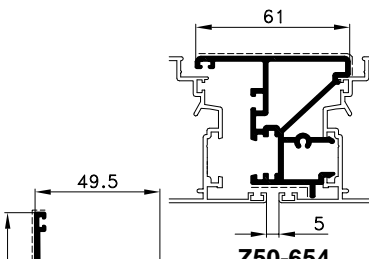
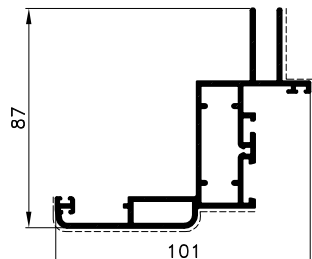
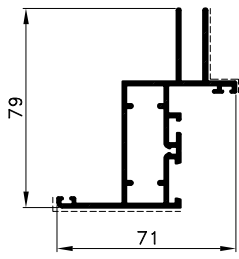
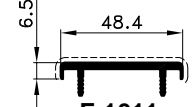
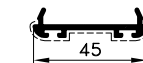
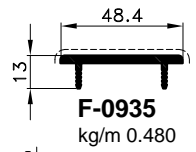
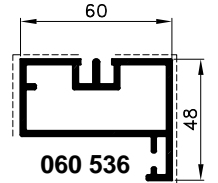
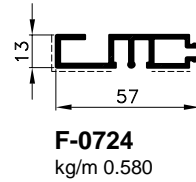
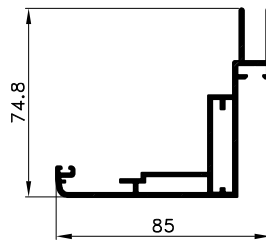
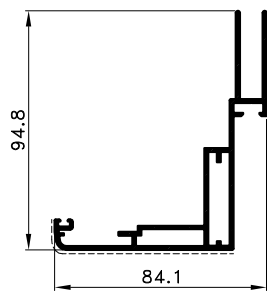
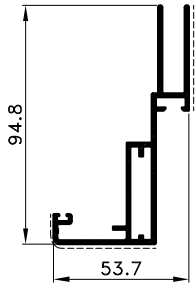
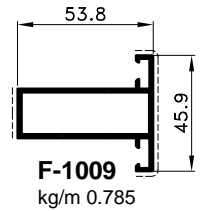
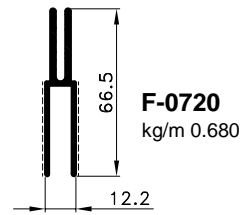
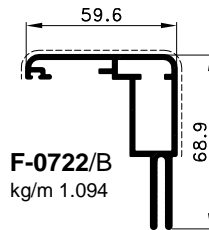
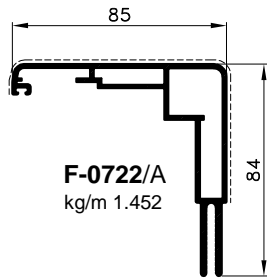
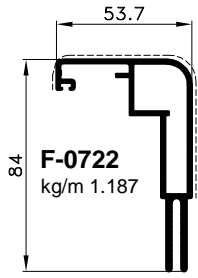

PREGRADNA VRATA **AD 60**



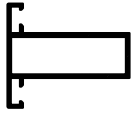

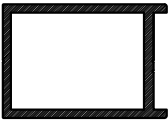
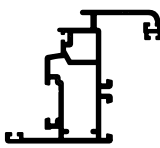
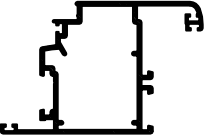
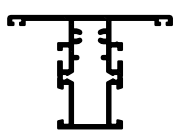
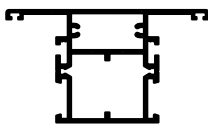
PROFILI





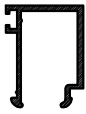

Oznaka	Izgled-presjek	Težina /kg/ml/	Opseg /mm/	I_x /cm ⁴ /	W_x /cm ³ /
F-0720		0.680	282		
F-0721		1.111	435		
F-0721/A		1.360	511		
F-0721/B		1.220	431		
F-0722		1.187	380		
F-0722/A		1.452	446		
F-0722/B		1.094	362		
F-0724		0.580	281		
F-0935		0.480	149		

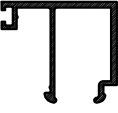
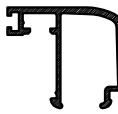
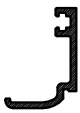
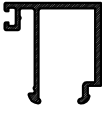
Oznaka	Izgled-presjek	Težina /kg/ml/	Opseg /mm/	I_x /cm ⁴ /	W_x /cm ³ /
F-1009		0.785	240		
F-1011		0.44	165		
P45-644		0.32	153		
F-1102		0.839	154		
Z50-639		1.160	413		
Z50-640		1.368	433		
Z50-641		1.089	368		
Z50-642		1.352	403		
Z50-653		2.281	560		

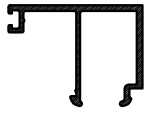
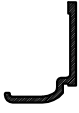
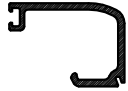
Oznaka	Izgled-presjek	Težina /kg/ml/	Opseg /mm/	I_x /cm ⁴ /	W_x /cm ³ /
Z50-654		1.019	315		
Z50-658		1.883	473		
Z50-659		1.171	434		
Z50-659/30		1.514	542		
060 536		1.320	291		
F-0201		0.929	180		
M45-709		0.258	153		
M45-740		0.258	148		
Z40-636		0.261	141		

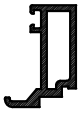
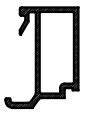
Oznaka	Izgled-presjek	Težina /kg/ml/	Opseg /mm/	I_x /cm ⁴ /	W_x /cm ³ /
Z40-644		0.275	166		
Z40-646		0.286	157		
Z40-647		0.226	137		
Z40-648		0.268	125		
Z40-649		0.221	105		
Z40-653		0.348	201		
Z40-653/B		0.356	199		
Z40-656		0.215	107		
Z40-658		0.318	184		

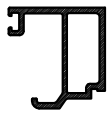
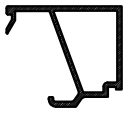
naka	Izgled-presjek	Težina /kg/ml/	Opseg /mm/	I_x /cm ⁴ /	W_x /cm ³ /
40-659		0.359	204		
40-660		0.179	89		
40-661		0.314	146		
40-662		0.245	116		
0784		0.330	105		
40-665		0.272	112		
0-666		0.289	122		
40-667		0.358	139		
40-668		0.326	135		

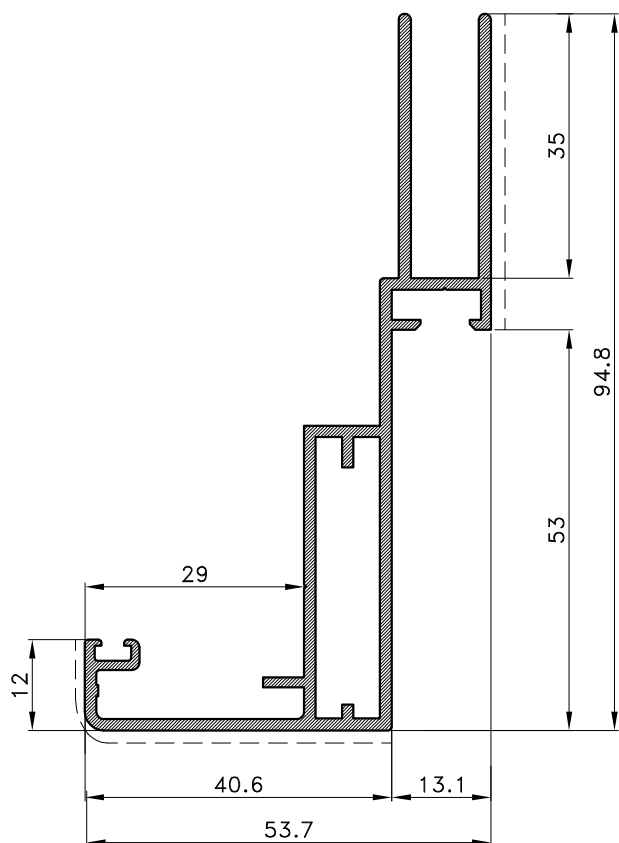

Profil okvira		
Art.-Br.	F-0721	
Težina	kg/m	1.111
Opseg	mm	435
Moment inercije	I _x (cm ⁴)	8.73
	I _y (cm ⁴)	14.58
	W _x (cm ⁴)	2.27
	W _y (cm ⁴)	4.35
Dužina isporuke	mm	6500

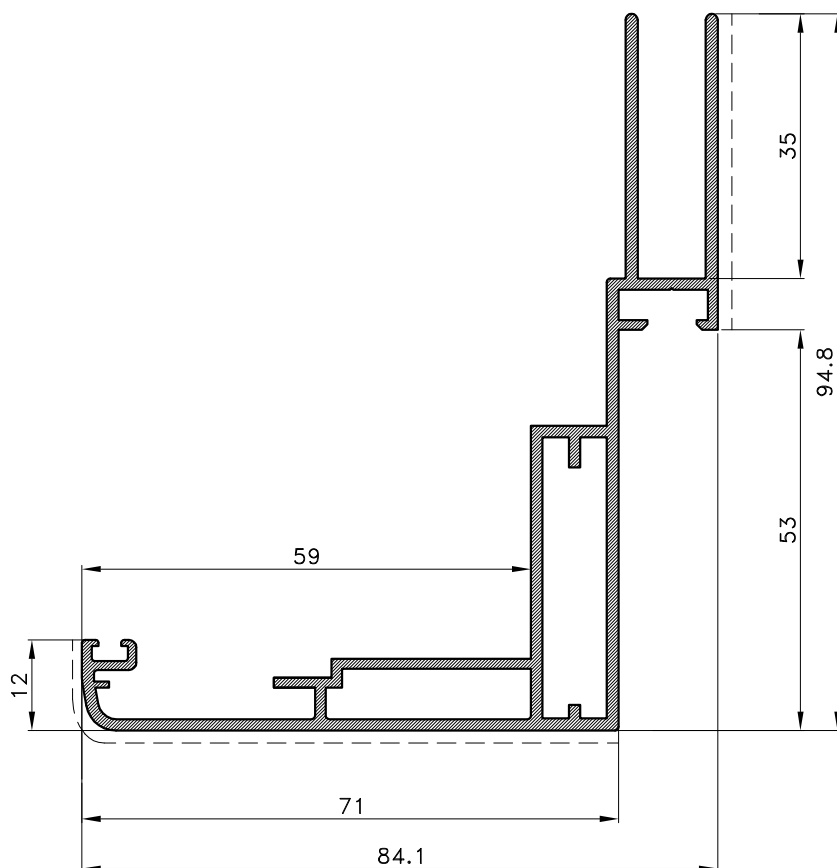

Profil okvira		
Art.-Br.	F-0721/A	
Težina	kg/m	1.360
Opseg	mm	511
Moment inercije	I _x (cm ⁴)	8.73
	I _y (cm ⁴)	14.58
	W _x (cm ⁴)	2.27
	W _y (cm ⁴)	4.35
Dužina isporuke	mm	6500

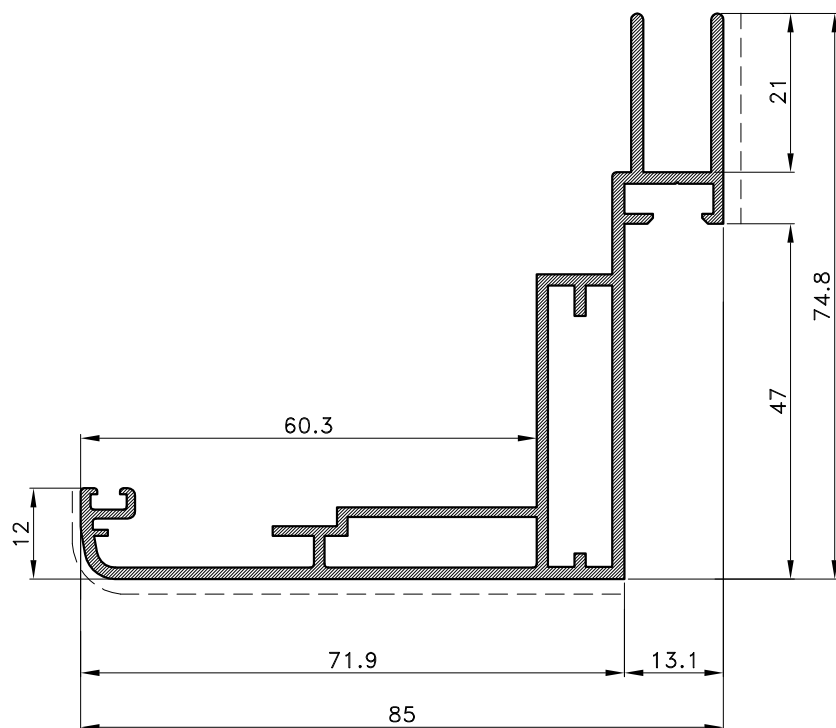

Profil okvira		
Art.-Br.	F-0721/B	
Težina	kg/m	1.220
Opseg	mm	431
Moment inercije	I_x (cm ⁴)	8.73
	I_y (cm ⁴)	14.58
	W_x (cm ⁴)	2.27
	W_y (cm ⁴)	4.35
Dužina isporuke	mm	6500

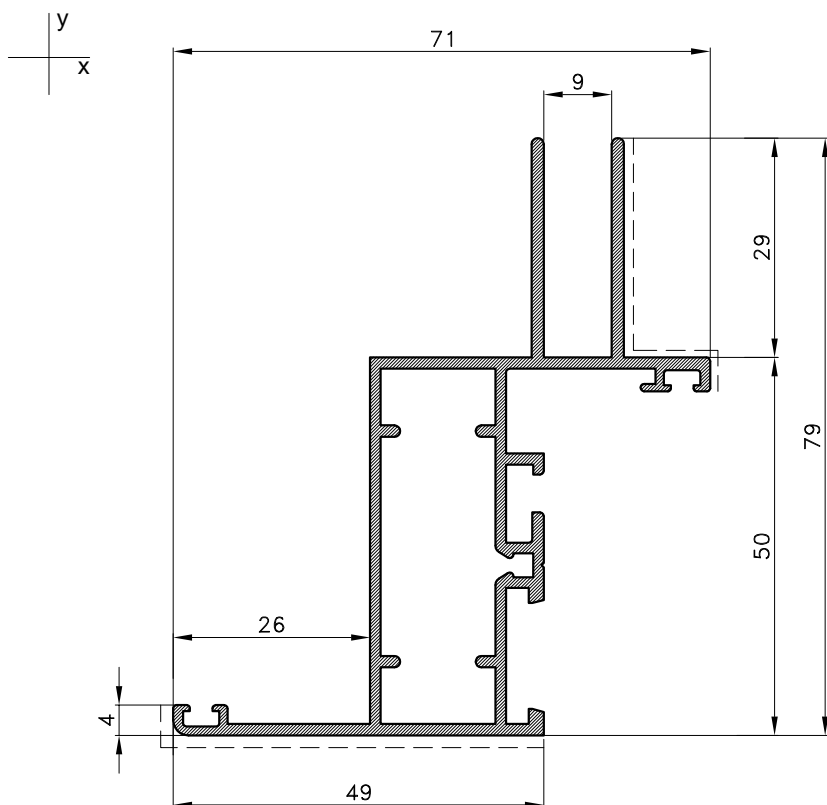

Profil okvira za al. krilo		
Art.-Br.	Z50-659	
Težina	kg/m	1.171
Opseg	mm	434
Moment inercije	I_x (cm ⁴)	8.73
	I_y (cm ⁴)	14.58
	W_x (cm ⁴)	2.27
	W_y (cm ⁴)	4.35
Dužina isporuke	mm	6500

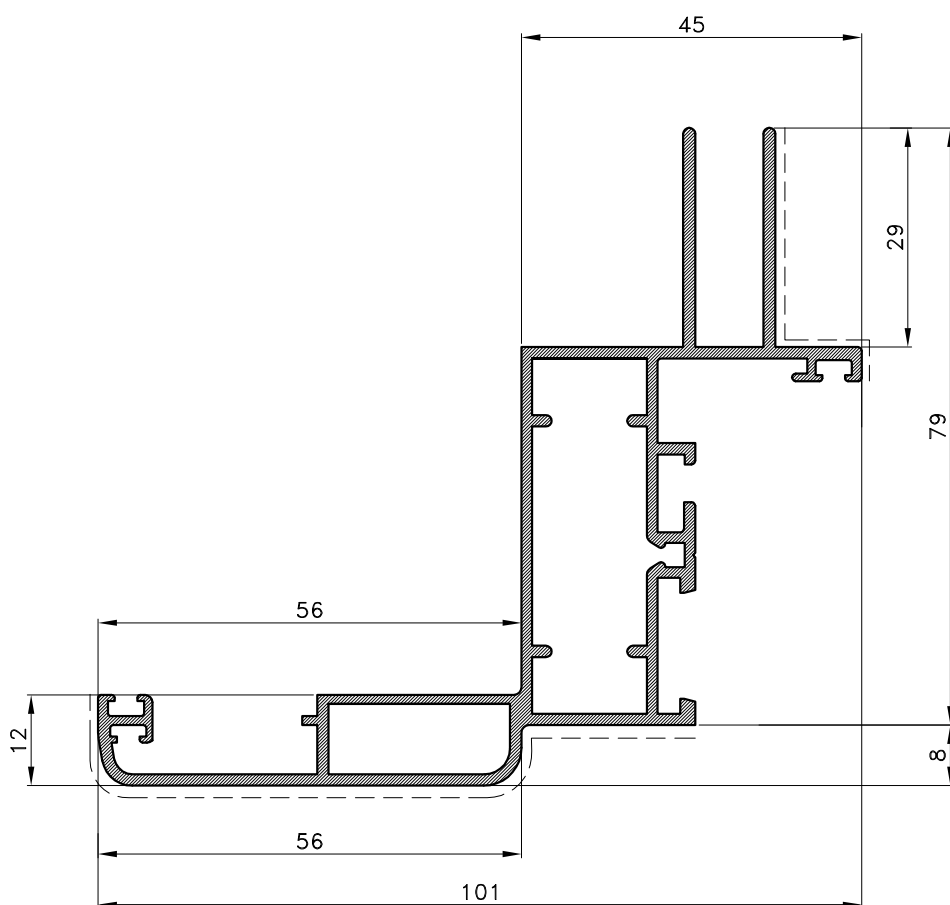

Profil okvira		
Art.-Br.	Z50-659/30	
Težina	kg/m	1.514
Opseg	mm	542
Moment inercije	I_x (cm ⁴)	8.73
	I_y (cm ⁴)	14.58
	W_x (cm ⁴)	2.27
	W_y (cm ⁴)	4.35
Dužina isporuke	mm	6500

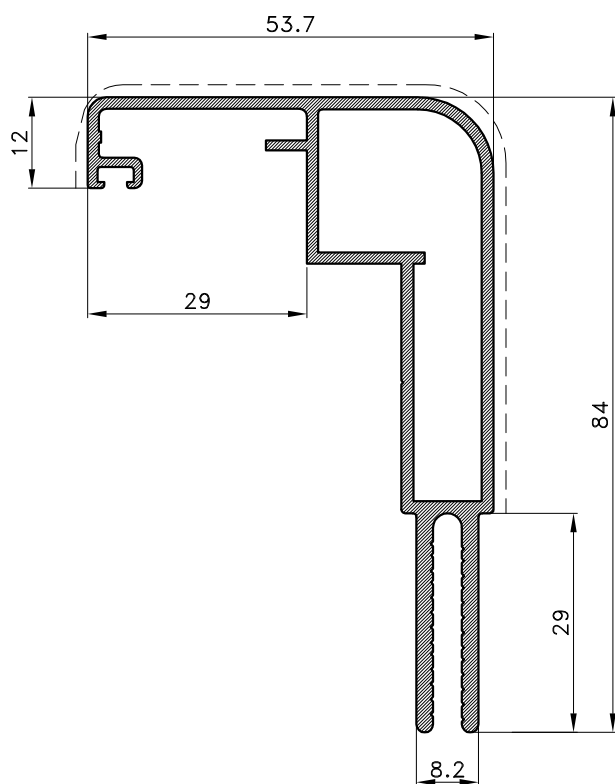

Profil okvira		
Art.-Br.	F-0722	
Težina	kg/m	1.187
Opseg	mm	380
Moment inercije	I _x (cm ⁴)	8.73
	I _y (cm ⁴)	14.58
	W _x (cm ⁴)	2.27
	W _y (cm ⁴)	4.35
Dužina isporuke	mm	6500

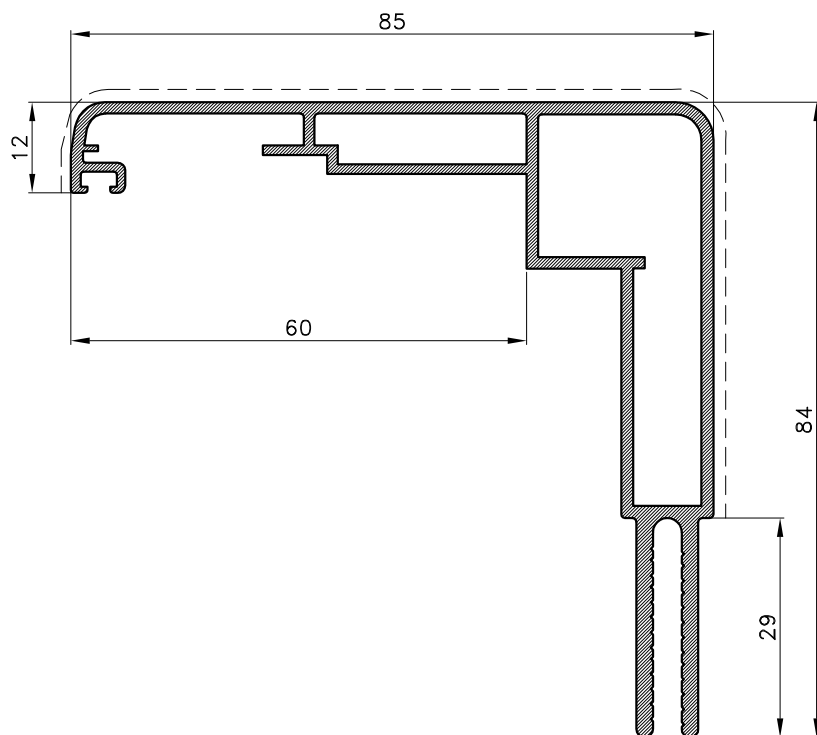

Profil okvira		
Art.-Br.	F-0722/A	
Težina	kg/m	1.452
Opseg	mm	446
Moment inercije	I _x (cm ⁴)	8.73
	I _y (cm ⁴)	14.58
	W _x (cm ⁴)	2.27
	W _y (cm ⁴)	4.35
Dužina isporuke	mm	6500



Profil okvira		
Art.-Br.	F-0722/B	
Težina	kg/m	1.094
Opseg	mm	362
Moment inercije	I _x (cm ⁴)	8.73
	I _y (cm ⁴)	14.58
	W _x (cm ⁴)	2.27
	W _y (cm ⁴)	4.35
Dužina isporuke	mm	6500

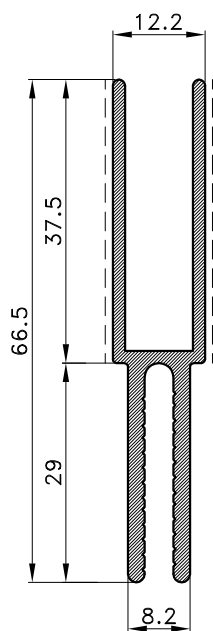
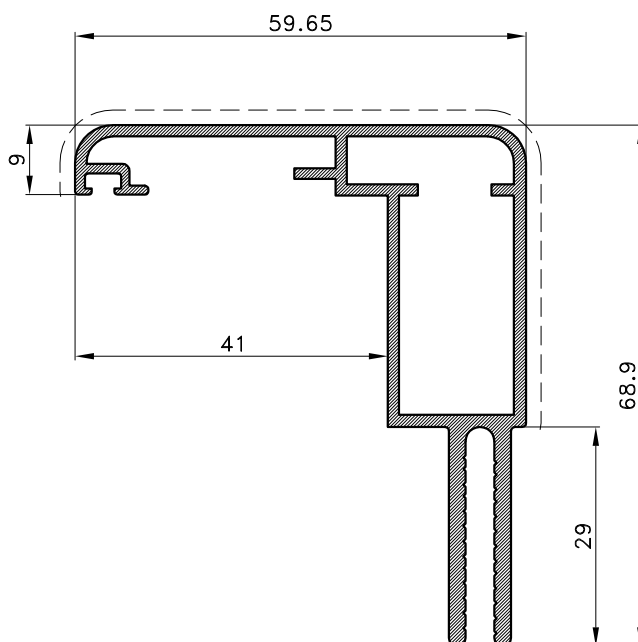

Profil proširivač		
Art.-Br.	F-0720	
Težina	kg/m	0.680
Opseg	mm	282
Moment inercije	I _x (cm ⁴)	8.73
	I _y (cm ⁴)	14.58
	W _x (cm ⁴)	2.27
	W _y (cm ⁴)	4.35
Dužina isporuke	mm	6500

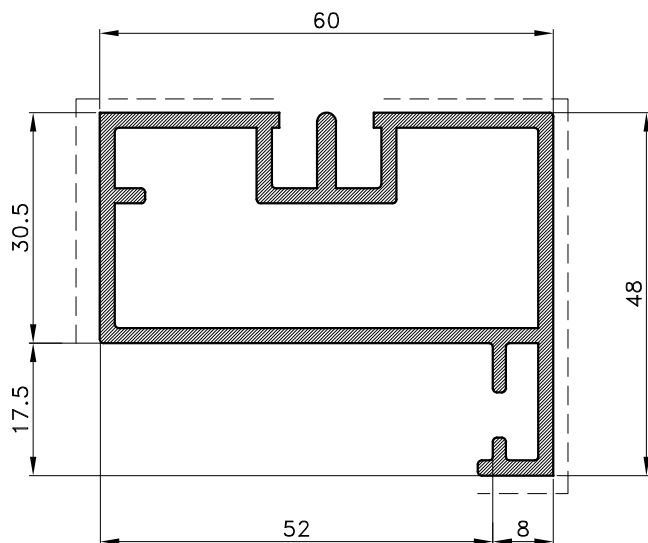

Profil prečke s nasvjetlom		
Art.-Br.	060 536	
Težina	kg/m	1.320
Opseg	mm	291
Moment inercije	I_x (cm ⁴)	8.73
	I_y (cm ⁴)	14.58
	W_x (cm ⁴)	2.27
	W_y (cm ⁴)	4.35
Dužina isporuke	mm	6500

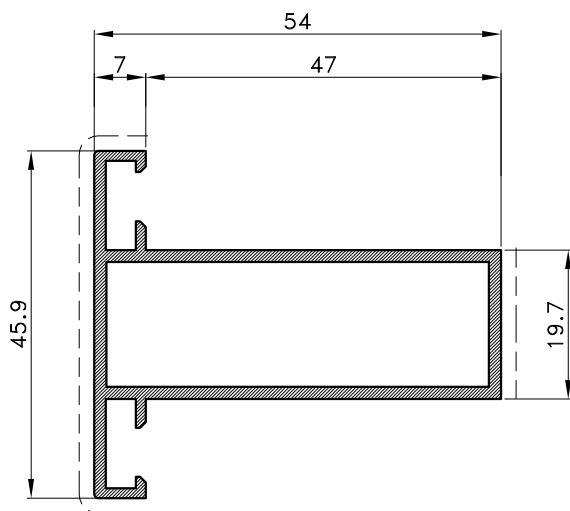

Profil prečke s nadsvijetlom		
Art.-Br.	F-1009	
Težina	kg/m	0.785
Opseg	mm	240
Moment inercije	I_x (cm ⁴)	8.73
	I_y (cm ⁴)	14.58
	W_x (cm ⁴)	2.27
	W_y (cm ⁴)	4.35
Dužina isporuke	mm	6500

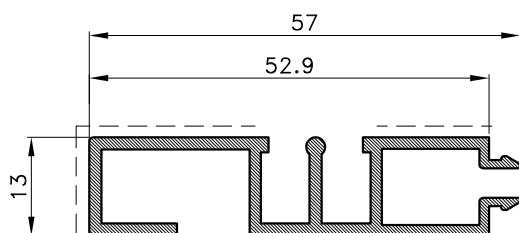

Staklolajsna u nadsvijetlu		
Art.-Br.	F-0724	
Težina	kg/m	0.580
Opseg	mm	281
Dužina isporuke	mm	6500

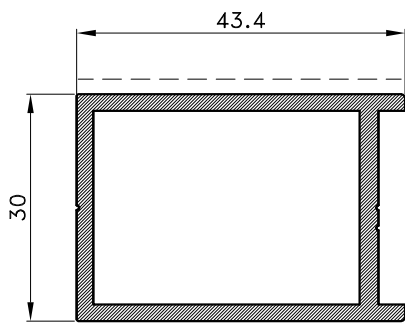

Profil okvira staklenih vrata		
Art.-Br.	F-1102	
Težina	kg/m	0.839
Opseg	mm	154
Moment inercije	I _x (cm ⁴)	8.73
	I _y (cm ⁴)	14.58
	W _x (cm ⁴)	2.27
	W _y (cm ⁴)	4.35
Dužina isporuke	mm	6500

Obuhvatni profil stakl. vrata		
Art.-Br.	F-1011	
Težina	kg/m	0.440
Opseg	mm	165
Dužina isporuke	mm	6500

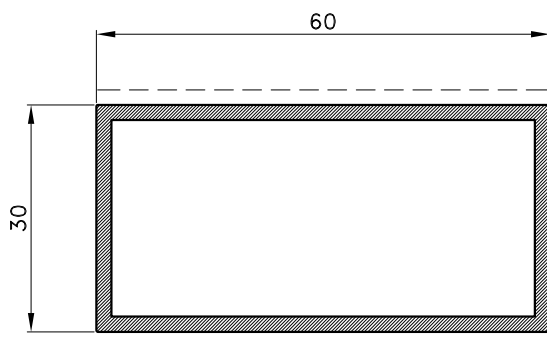
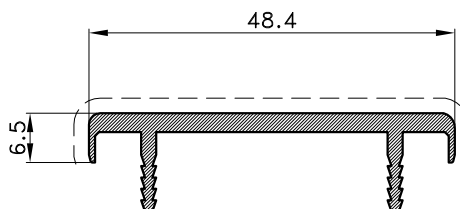

Prečka staklenih vrata		
Art.-Br.	F-0201	
Težina	kg/m	0.929
Opseg	mm	180
Dužina isporuke	mm	6500

Obuhvatni profil drvenog krila vrata		
Art.-Br.	F-0935	
Težina	kg/m	0.480
Opseg	mm	149
Dužina isporuke	mm	6500

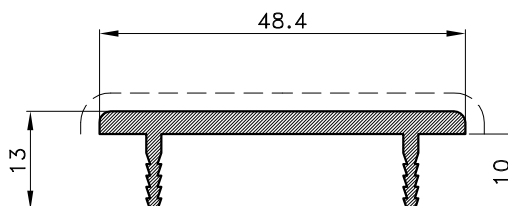

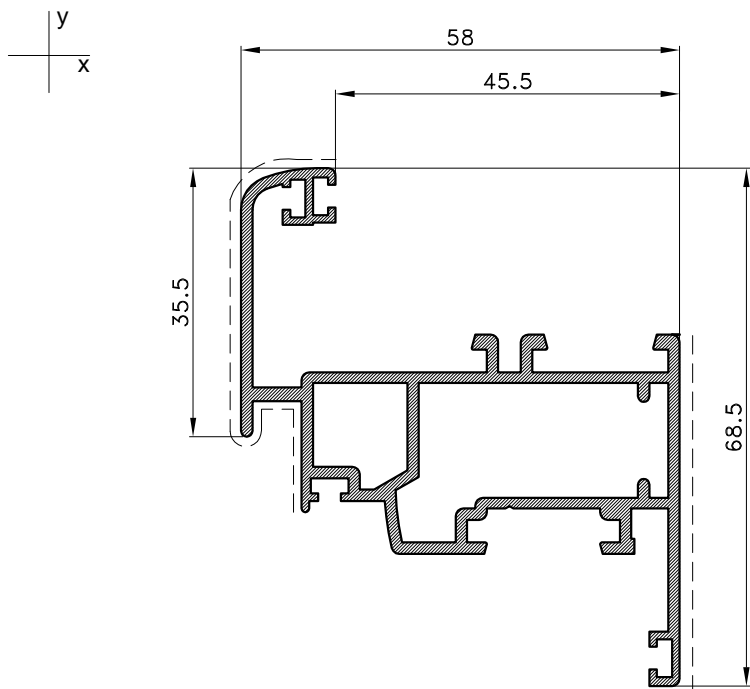

Profil krila vrata		
Art.-Br.	Z50-639	
Težina	kg/m	1.160
Opseg	mm	413
Moment inercije	I_x (cm ⁴)	8.73
	I_y (cm ⁴)	14.58
	W_x (cm ⁴)	2.27
	W_y (cm ⁴)	4.35
Dužina isporuke	mm	6500

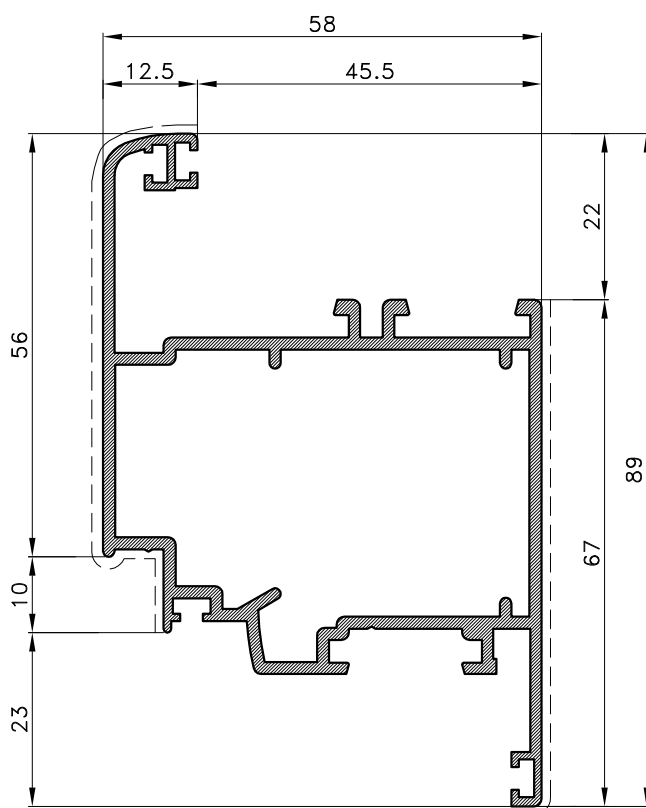

Profil krila vrata		
Art.-Br.	Z50-640	
Težina	kg/m	1.368
Opseg	mm	433
Moment inercije	I_x (cm ⁴)	8.73
	I_y (cm ⁴)	14.58
	W_x (cm ⁴)	2.27
	W_y (cm ⁴)	4.35
Dužina isporuke	mm	6500

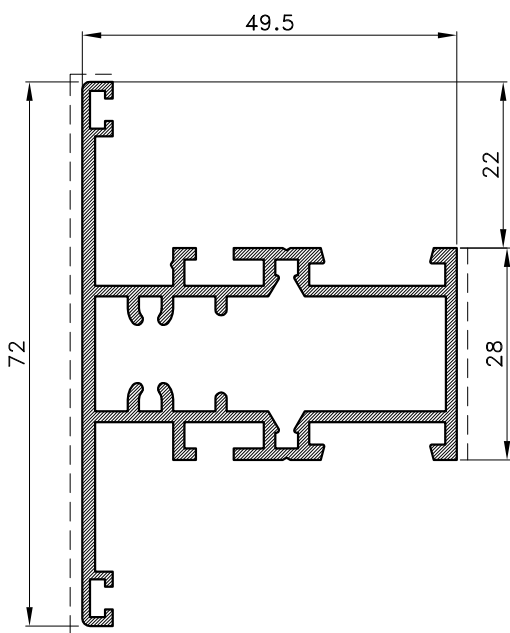

Profil prečke		
Art.-Br.	Z50-641	
Težina	kg/m	1.089
Opseg	mm	368
Moment inercije	I_x (cm ⁴)	8.73
	I_y (cm ⁴)	14.58
	W_x (cm ⁴)	2.27
	W_y (cm ⁴)	4.35
Dužina isporuke	mm	6500

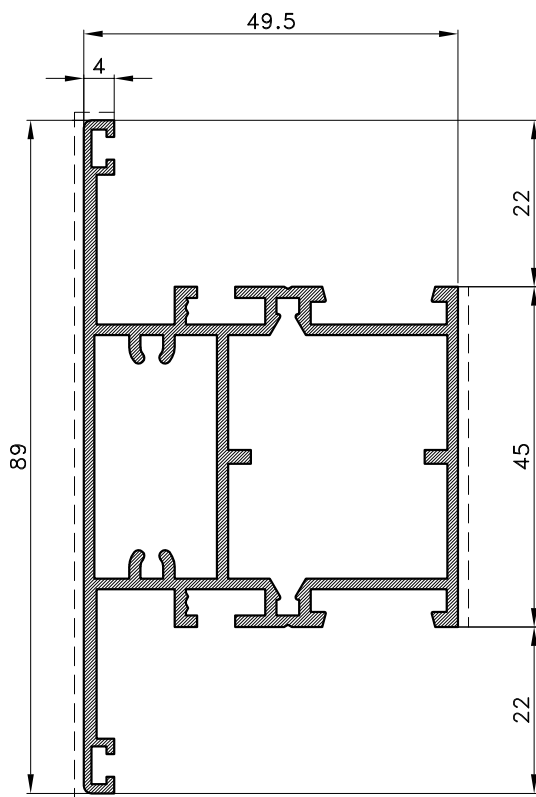

Profil prečke		
Art.-Br.	Z50-642	
Težina	kg/m	1.352
Opseg	mm	403
Moment inercije	I_x (cm ⁴)	8.73
	I_y (cm ⁴)	14.58
	W_x (cm ⁴)	2.27
	W_y (cm ⁴)	4.35
Dužina isporuke	mm	6500

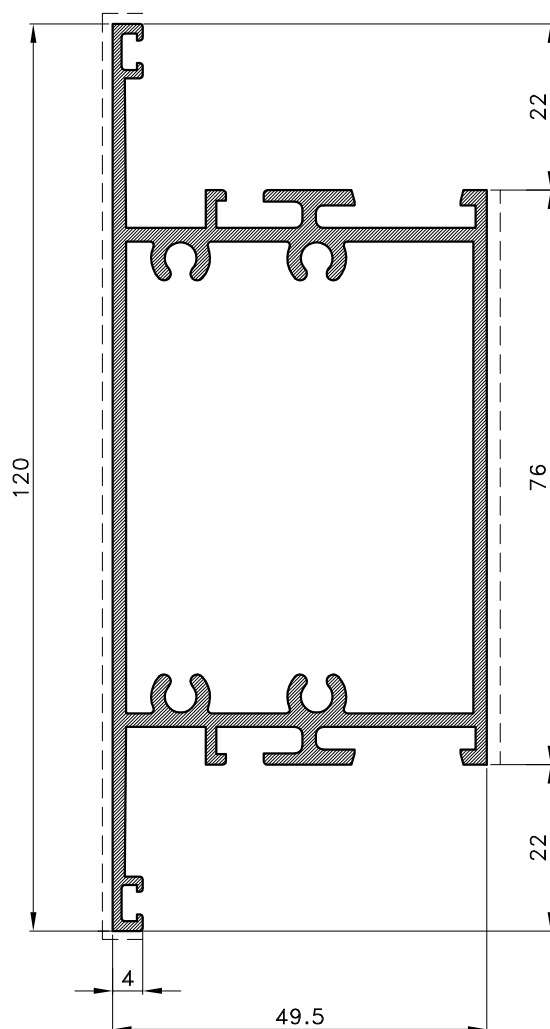
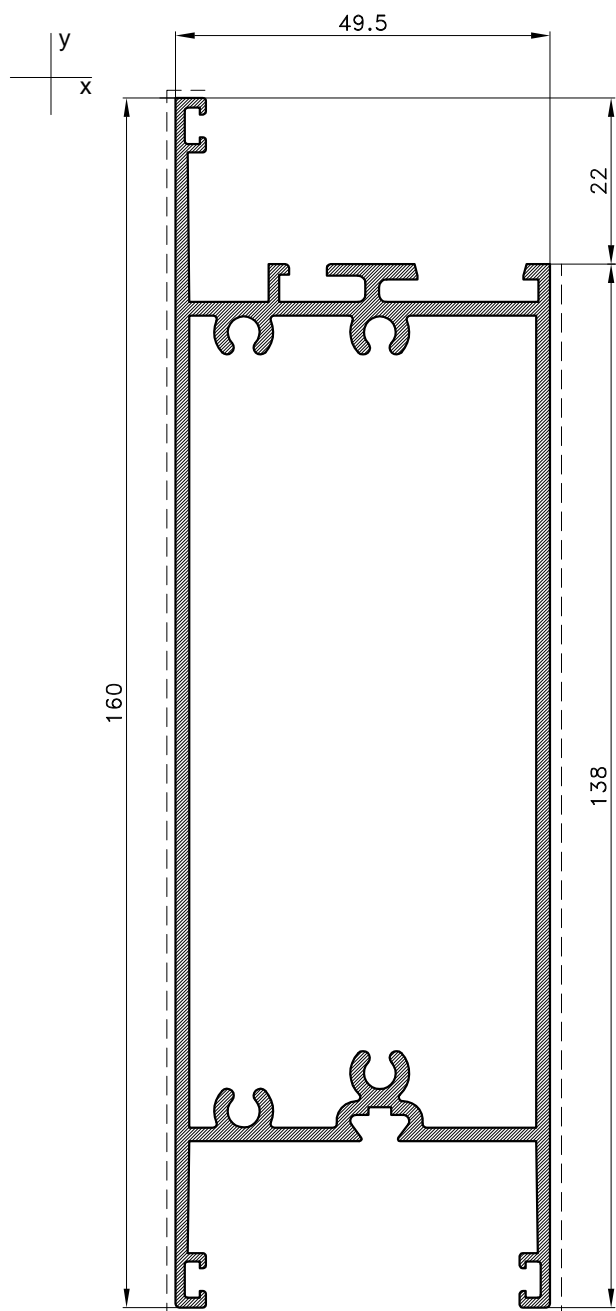

Parapetna prečka		
Art.-Br.	Z50-653	
Težina	kg/m	2.281
Opseg	mm	560
Moment inercije	I_x (cm ⁴)	8.73
	I_y (cm ⁴)	14.58
	W_x (cm ⁴)	2.27
	W_y (cm ⁴)	4.35
Dužina isporuke	mm	6500

Profil prečke		
Art.-Br.	Z50-658	
Težina	kg/m	1.833
Opseg	mm	473
Moment inercije	I_x (cm ⁴)	8.73
	I_y (cm ⁴)	14.58
	W_x (cm ⁴)	2.27
	W_y (cm ⁴)	4.35
Dužina isporuke	mm	6500

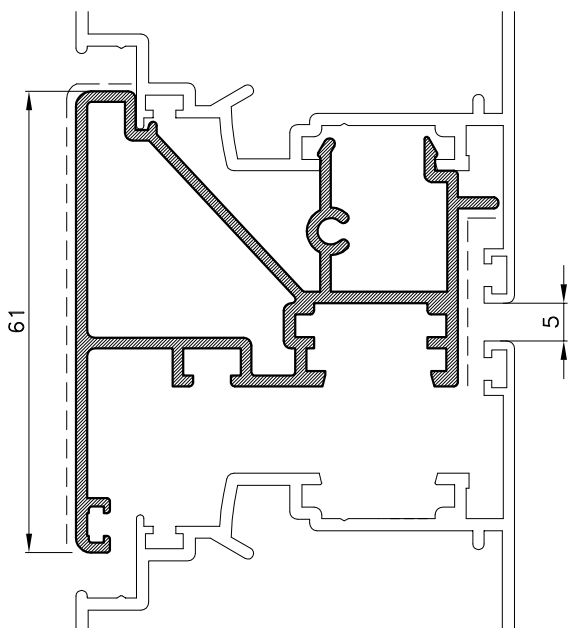

Profil kombatute		
Art.-Br.	Z50-654	
Težina	kg/m	1.019
Opseg	mm	315
Moment inercije	I _x (cm ⁴)	8.73
	I _y (cm ⁴)	14.58
	W _x (cm ⁴)	2.27
	W _y (cm ⁴)	4.35
Dužina isporuke	mm	6500

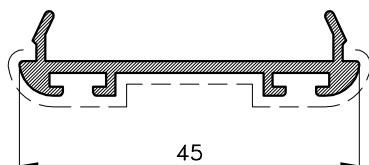

Profil maska		
Art.-Br.	P45-644	
Težina	kg/m	0.32
Opseg	mm	153
Dužina isporuke	mm	6500

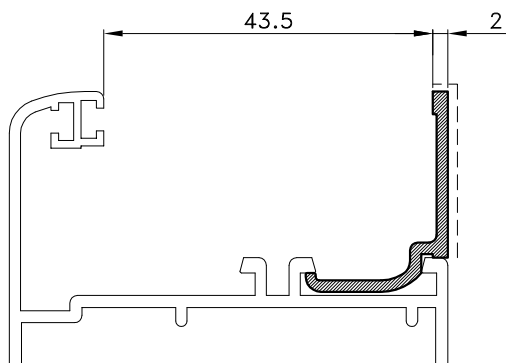
Z40-660

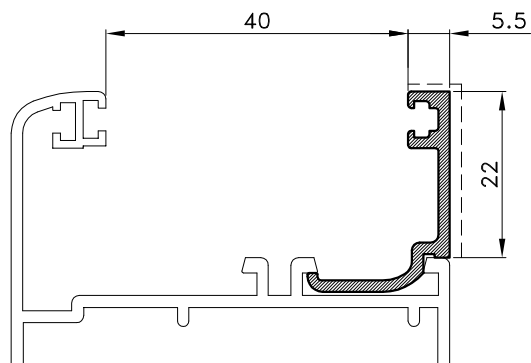
 težina: kg/ml 0.179
 svj.povr. mm 24

Z40-656

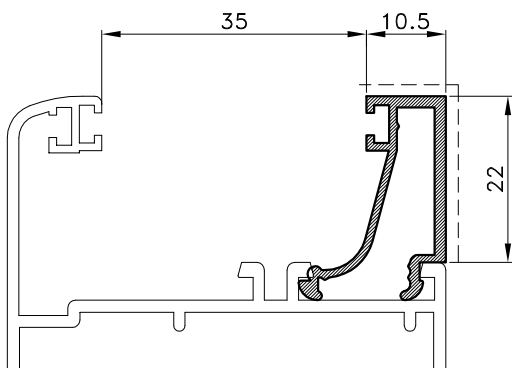
 težina: kg/ml 0.215
 svj.povr. mm 27

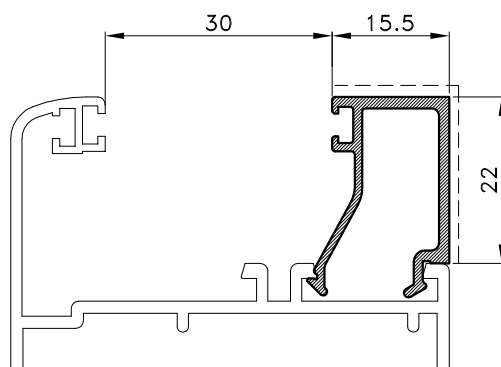

Z40-636

težina: kg/ml 0.261
svj.povr. mm 32



M45-709

težina: kg/ml 0.258
svj.povr. mm 37

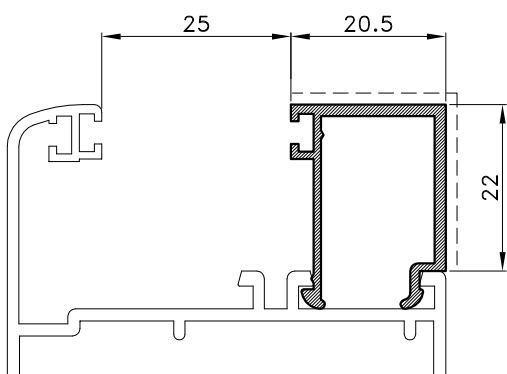

Z40-644

težina: kg/ml 0.275
svj.povr. mm 42

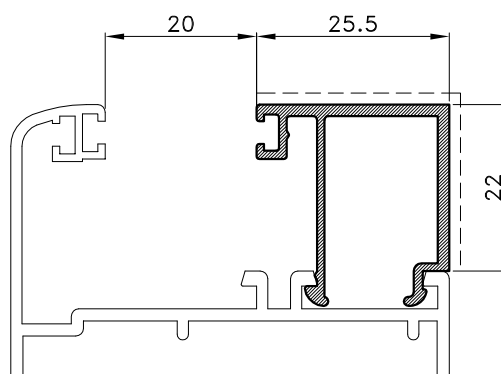

Z40-658

težina: kg/ml 0.318
svj.povr. mm 47

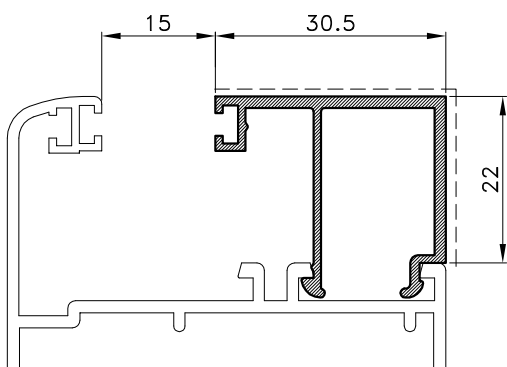

Z40-653

težina: kg/ml 0.347
svj.povr. mm 52

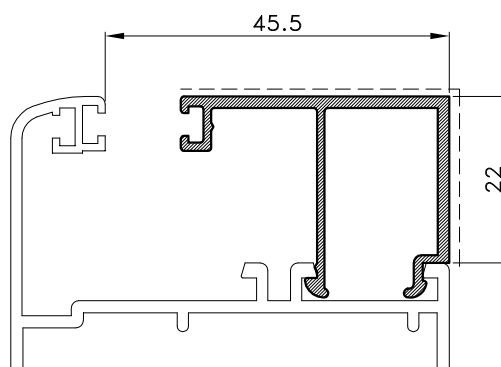

Z40-659

težina: kg/ml 0.359
svj.povr. mm 57

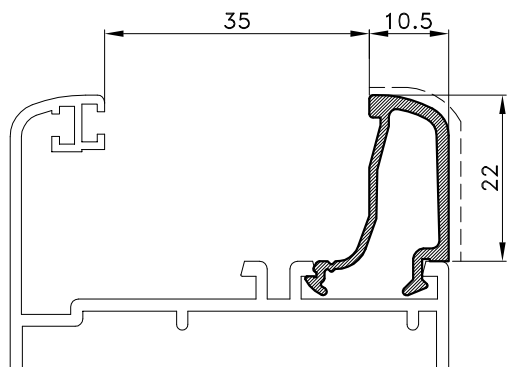

Z40-647

težina: kg/ml 0.226
svj.povr. mm 30

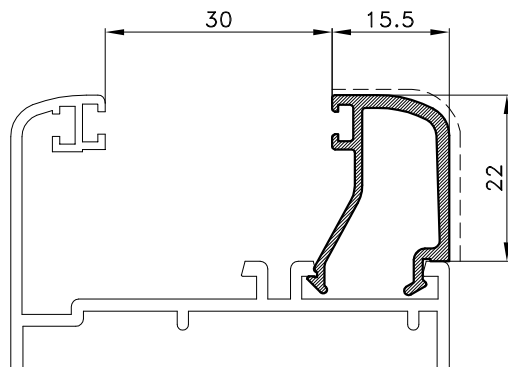

M45-740

težina: kg/ml 0.258
svj.povr. mm 35

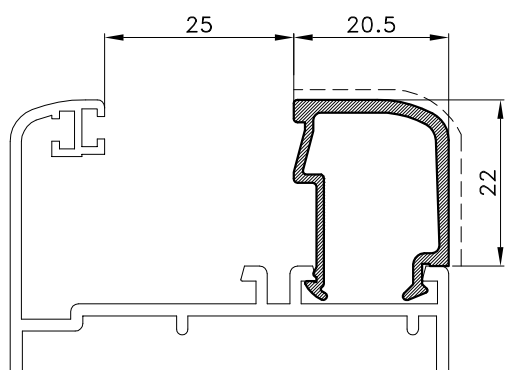

Z40-646

težina: kg/ml 0.286
svj.povr. mm 40

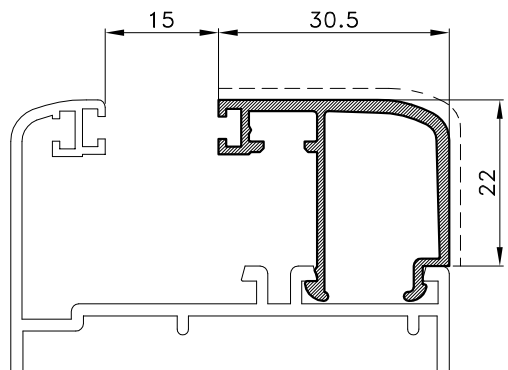

Z40-653/B

težina: kg/ml 0.356
svj.povr. mm 53

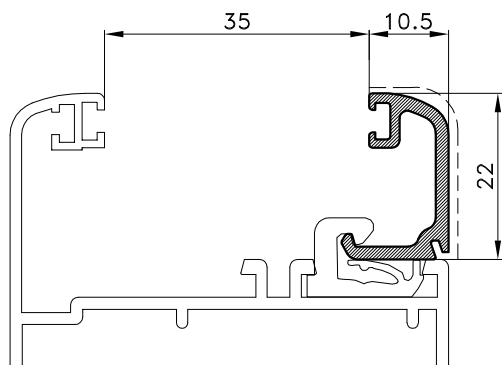

Z40-649

težina: kg/ml 0.221
svj.povr. mm 30

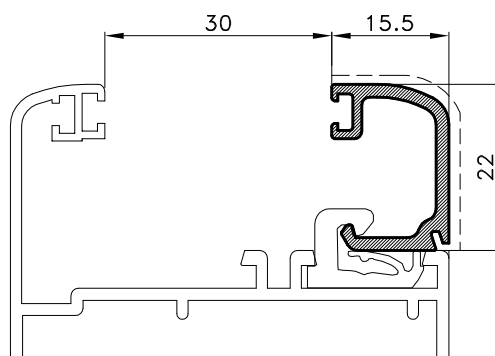

Z40-662

težina: kg/ml 0.245
svj.povr. mm 35

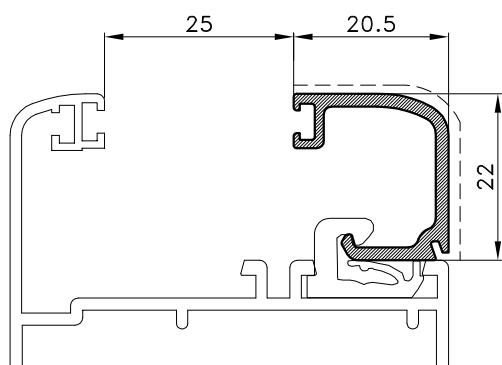

Z40-648

težina: kg/ml 0.268
svj.povr. mm 40

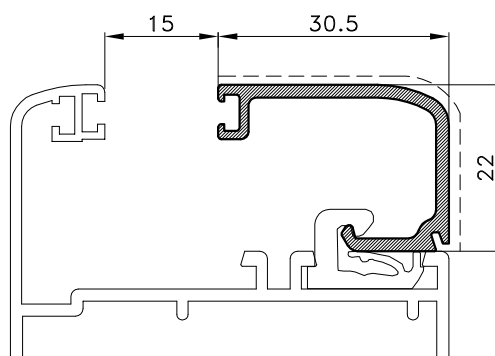

Z40-661

težina: kg/ml 0.314
svj.povr. mm 50

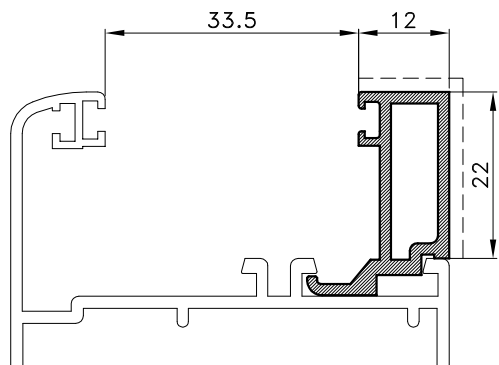

F-0784

težina: kg/ml 0.330
svj.povr. mm 34

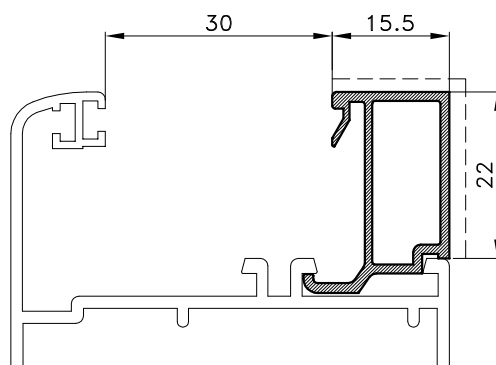

Z40-665

težina: kg/ml 0.272
svj.povr. mm 37

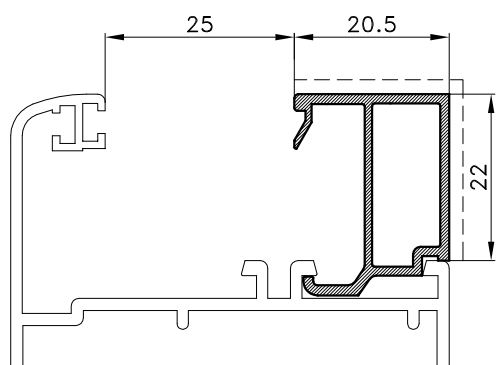

Z40-666

težina: kg/ml 0.289
svj.povr. mm 42

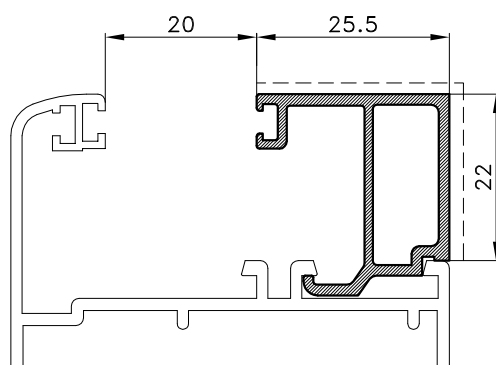

Z40-667

težina: kg/ml 0.358
svj.povr. mm 47

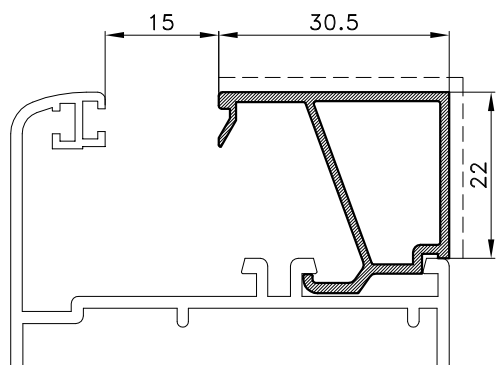

Z40-668

težina: kg/ml 0.326
svj.povr. mm 52

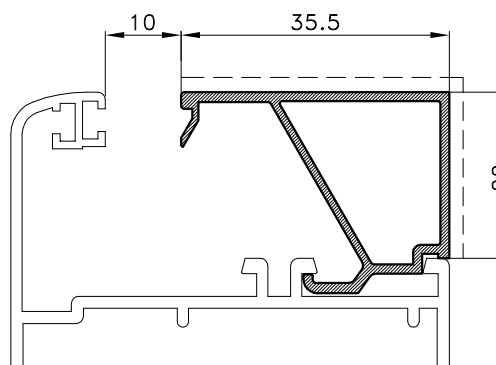



Z40-669

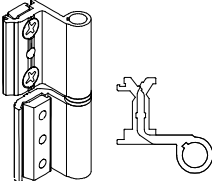
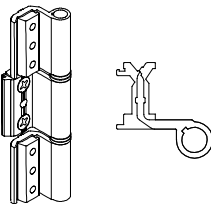
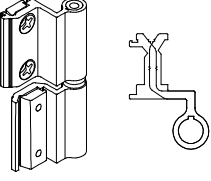
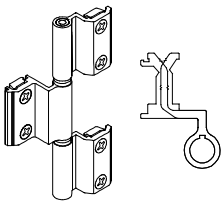
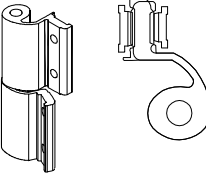
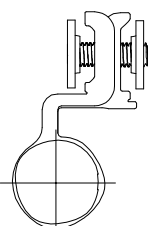

težina kg/m 0.347
svj. povr.mm 57

CODE	Izgled-presjek	Opis	Materijal	Nap.
111.001.01 02 03		- Dvodijelna šarka <i>EURO ŽLIJEB</i> - Stara oznaka E-100 - Boje: 01- bijela; 02 - siva;03 - crna		
111.002.01 02 03		- Trodjelna šarka <i>EURO ŽLIJEB</i> - Stara oznaka E-120 - Boje: 01- bijela; 02 - siva;03 - crna		
111.003.01 02 03		- Dvodijelna šarka-vani <i>EURO ŽLIJEB</i> - Stara oznaka EV-110 - Boje: 01- bijela; 02 - siva;03 - crna		
111.004.01 02 03		- Trodjelna šarka-vani <i>EURO ŽLIJEB</i> - Stara oznaka EV-130 - Boje: 01- bijela; 02 - siva;03 - crna		
114.001.01 02 03		- Dvodijelna šarka- <i>EURO ŽLIJEB</i> - Stara oznaka 2006.00.305-s 310-b 313-c		
113.003.01 02 03		- Dvodijelna šarka- <i>EURO ŽLIJEB</i> - Stara oznaka: VENUS - Boje: 01- bijela; 02 - siva;03 - crna		

CODE	Izgled-presjek	Opis	Materijal	Nap.
111.012.01 02 03		- Dvodijelna šarka (vijci 4.8x32, DIN 7981- kom 3 i M6x9, DIN 85- kom 3) - Stara oznaka AD-100 Boje: 01- bijela; 02 - siva;03 - crna	Al.	
730.008		- Kutna spojnica prozora-za komoru 29x15.2 - Stara oznaka: 0409 ,1001	Zamak #3	
710.035		- Kutna spojnica za komoru 29x15,2 - Stara oznaka K-0868-A	Al.	
710.075		- Kutna spojnica za komoru 29x15,2 - Stara oznaka K-0868	Al.	
730.009		- Kutna spojnica prozora -za komoru 29x35.5 - Stara oznaka: 4004 ,2001	Zamak #3	
710.059		- Kutna spojnica za komoru 29x35,5 - Stara oznaka K-0795	Al.	

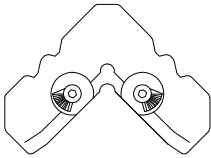
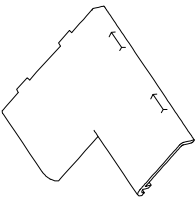
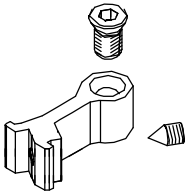
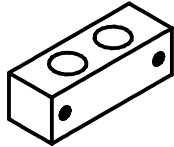
CODE	Izgled-presjek	Opis	Materijal	Nap.
710.072	<p>L=28,5mm M8x13</p>	- Kutna spojnica za komoru 29x35,5 - Stara oznaka K-0795	Al.	
710.057	<p>25.1 M8x13</p>	- Kutna spojnica za vrata (za komoru 25.6x35.2) - Stara oznaka: K-0795/E	Al.	
710.102	<p>3.1 M8x10</p>	- Kutna spojnica za komoru 8.5x31.4 - Stara oznaka: K-061059/31	Al.	
710.103	<p>6</p>	- Kutna spojnica za komoru 6.7x25 - Stara oznaka K-061015/6	Al.	
710.104	<p>9</p>	- Kutna spojnica za komoru 9.3x20.6 - Stara oznaka K-0558/9	Al.	
710.105	<p>18</p>	- Kutna spojnica za komoru 18.5x16.5 - Stara oznaka K-0558/18	Al.	

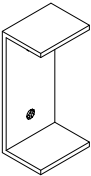
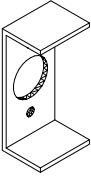
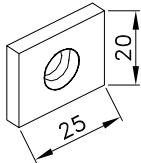
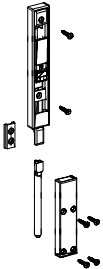
CODE	Izgled-presjek	Opis	Materijal	Nap.
730.001		- Kutna spojnica za komoru 1.7x4.7 - Stara oznaka: G112	Inox	
730.002		- Kutna spojnica za komoru 1.7x4.7 - Stara oznaka: G112/A	Inox	
730.010		- Kutna spojnica za komoru 6.5x27 - Stara oznaka: 5001	Inox	
730.003		- Kutna spojnica za komoru 6.5x27 - Stara oznaka: 0366	PVC	
710.066	 M8x13 M6x10	- Veznik (L=14.7mm) - Stara oznaka E-200	Al.	
370.014	 vijak 4.2x19 DIN 7982	- Veznik prečke - Stara oznaka: P-AD 100	PVC	

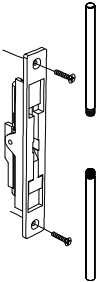
CODE	Izgled-presjek	Opis	Materijal	Nap.
710.106		- Veznik za prečku vrata (staklenih) - Stara oznaka: SP-01	Al.	
710.107		- Veznik za prečku vrata (staklenih) - Stara oznaka: SP-02	Al.	
521.105		- Podmetač za baglamu (koblenz- kubica) - Stara oznaka: PB-25/20	Al.	
143.006		- Zapinjač vanjski - Stara oznaka: GS 2170		
143.005		- Fiksni zapinjač-krakun za al.vrata - Stara oznaka: GS 2172		
144.002		- Preklopni zapinjač za dvokrilna vrata - Stara oznaka: 3008.00.xx (art. 2101)		

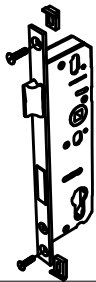
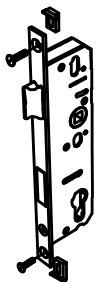
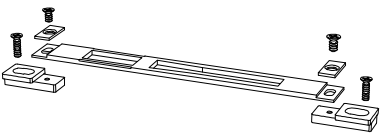
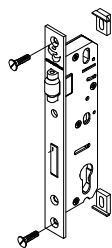
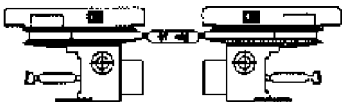
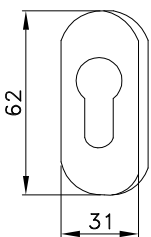
CODE	Izgled-presjek	Opis	Materijal	Nap.
124.016		- Brava 25 mm sa jezičkom - Stara oznaka: 3020.00	Inox Čelik	
124.001		- Brava 35 mm sa jezičkom - Stara oznaka: 3022.00	Inox Čelik	
124.003		-Prijvatnik jezička brave (šild) - Stara oznaka: 3016.00	Prokrom Čelik	
124.010		- Brava 35 mm sa valjkom - Stara oznaka: 3032.00	Inox Čelik	
364.014		- Umetak profila za okretanje Z50-654- otvaranje unutra - Stara oznaka: GT 502	PVC	
123.001.01 02 03		- Štitnik cilindra za bravu (par) - Stara oznaka: 149.805 - Boje: 01- bijela; 02 - siva;03 - crna	PVC	

CODE	Izgled-presjek	Opis	Materijal	Nap.
124.004.01 02 03		<ul style="list-style-type: none"> - Štitnik cilindra za bravu (par) - Stara oznaka: 1016.00 - Boje: 01- bijela; 02 - siva;03 - crna 	Zn Čelik	
124.014		<ul style="list-style-type: none"> - Uložak za bravu 31/45 - Stara oznaka: 5055.00.520 	Čelik	
103.001.01 02 03		<ul style="list-style-type: none"> - Ručke za vrata (par) - Stara oznaka: 890 - Boje: 01- bijela; 02 - siva;03 - crna 	AlSi Zamak	
104.001.01 02 03		<ul style="list-style-type: none"> - Ručke za vrata (par) - Stara oznaka: 1032.00 - Boje: 01- bijela; 02 - siva;03 - crna 	AlSi Zamak	
220.005		<ul style="list-style-type: none"> - Grupa glodala za obradu prečki prema profilu krila i okvira (Z50) - Stara oznaka: Grupa glodala Z50 	Čelik	
521.109		<ul style="list-style-type: none"> - pločica za ugradnju-manja - Stara oznaka: V-AD-110 		

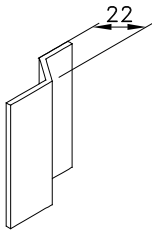
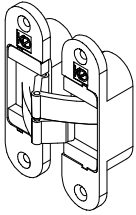
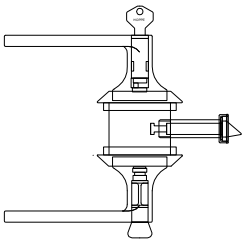
CODE	Izgled-presjek	Opis	Materijal	Nap.
521.110		<p>- Pločica za ugradnju veća- Stara oznaka:V-AD-120</p>		
110.002		<p>-Baglama K6700 (Koblentz Kubica)</p>		
120.000		<p>-Brava s ručkom -Hoppe HCS</p>		

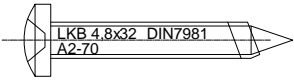
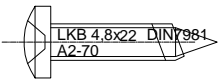
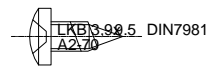
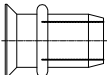
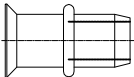
CODE	Izgled-presjek	Opis	Materijal	Nap.
433.046		Vijak 4.8x32 DIN 7981		
433.044		Vijak 4.8x22 DIN 7981		
433.015		Vijak 3.9x9.5 DIN 7981		
434.050	SGN M5 A2 	- zakivna matica M5X13 W-948		
434.051	SGN M5 A2 	- zakivna matica M5X16.5 W-948		

Okov za vrata: Brava Hoppe HCS (120.000) + baglama Koblenz - Kubica 6700 (110.002)

Brava-Hoppe HCS

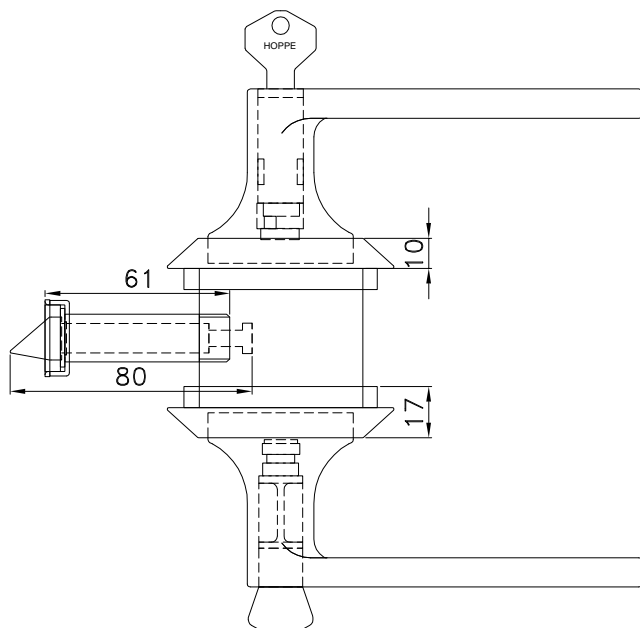
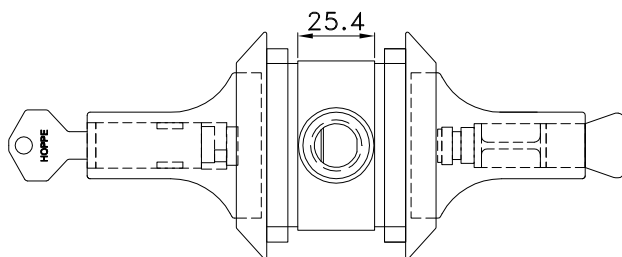
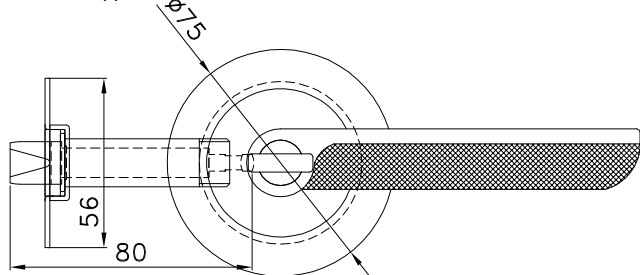

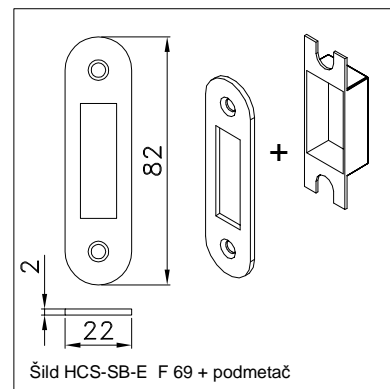
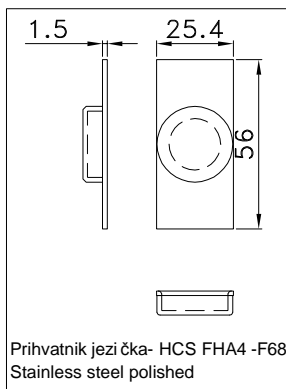
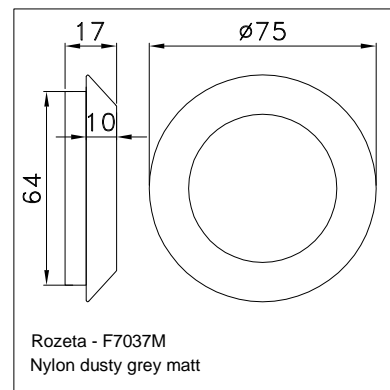
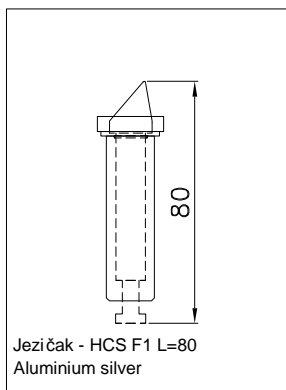

Stavke koje treba naručiti uz bravu :

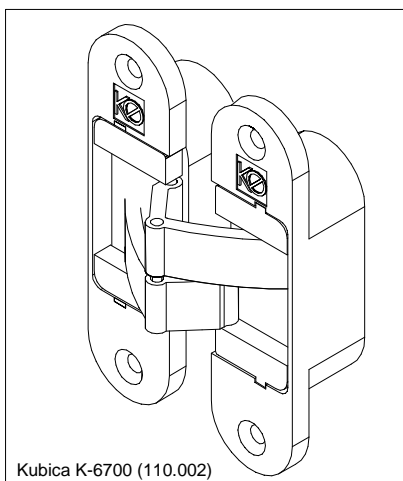

Baglama

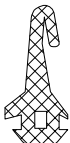

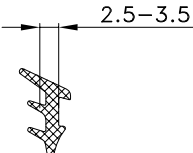
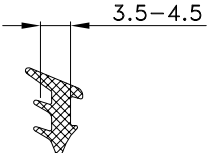
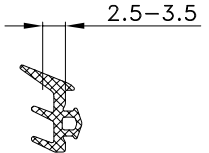
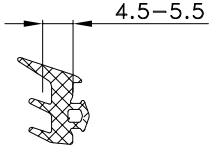
CODE	Izgled-presjek	Opis	Materijal	Nap.
331.001		- Srednja brtva - Stara oznaka: Z101	EPDM	80
321.001		- Brtva u krilu - Stara oznaka: Z106	EPDM	61
311.001		- Brtva prema staklu /unutarnja/ - Stara oznaka: 921	EPDM	71
311.002		-Brtva prema staklu /unutarnja/ - Stara oznaka: 918	EPDM	71
321.002		- Brtva prema staklu /vanjska/ - Stara oznaka : Z111	EPDM	61
321.003		- Brtva prema staklu /vanjska/ - Stara oznaka: Z113	EPDM	61

CODE	Izgled-presjek	Opis	Materijal	Nap.
311.007 311.008 311.009 311.010		-Brtva prema staklu /unutarnja/ - Stare oznake UP-5 nove oznake UP-6 UP-7 UP-8	311.007 311.008 311.009 311.010	EPDM 71
521.001		- Držać četkaste brtve L=2500 mm - Stara oznaka Z 801	Al.	
347.001		- Četkasta brtva L=2500 mm - Stara oznaka Z 802		
366.001		Kutni umetak za brtvu 331.001-otvaranje unutra L=50x50 -Stara oznaka: Z901	EPDM	
340.011		Četkasta brtva 7x9 -Stara oznaka: Četkasta brtva 7x9	EPDM	
314.004		Brtva prema drvenom krilu -Stara oznaka: 126.083	EPDM	

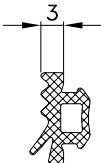
CODE	Izgled-presjek	Opis	Materijal	Nap.
314.005		-Brtva prema staklu nadsvjeta /obostrano/ -Stara oznaka:126039	EPDM	
351.011		- Brtva prema staklu /unutarnja/ nosi 3mm - Stara oznaka 02852	EPDM	71 (ShA)

PRESJECI S DRVENIM KRILOM

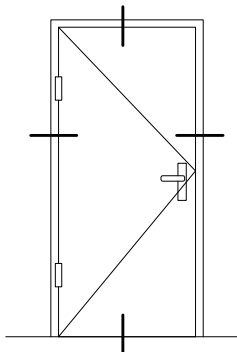

- IZVEDBA DOVRATNIKA S PROFILIMA
F-0721 i F-0722
- Drveno krilo vrata d=48 mm

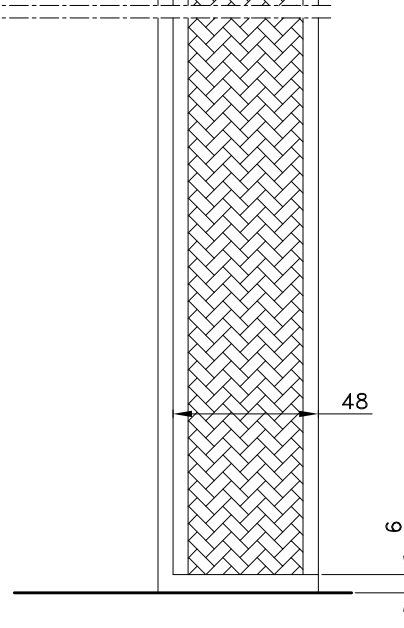
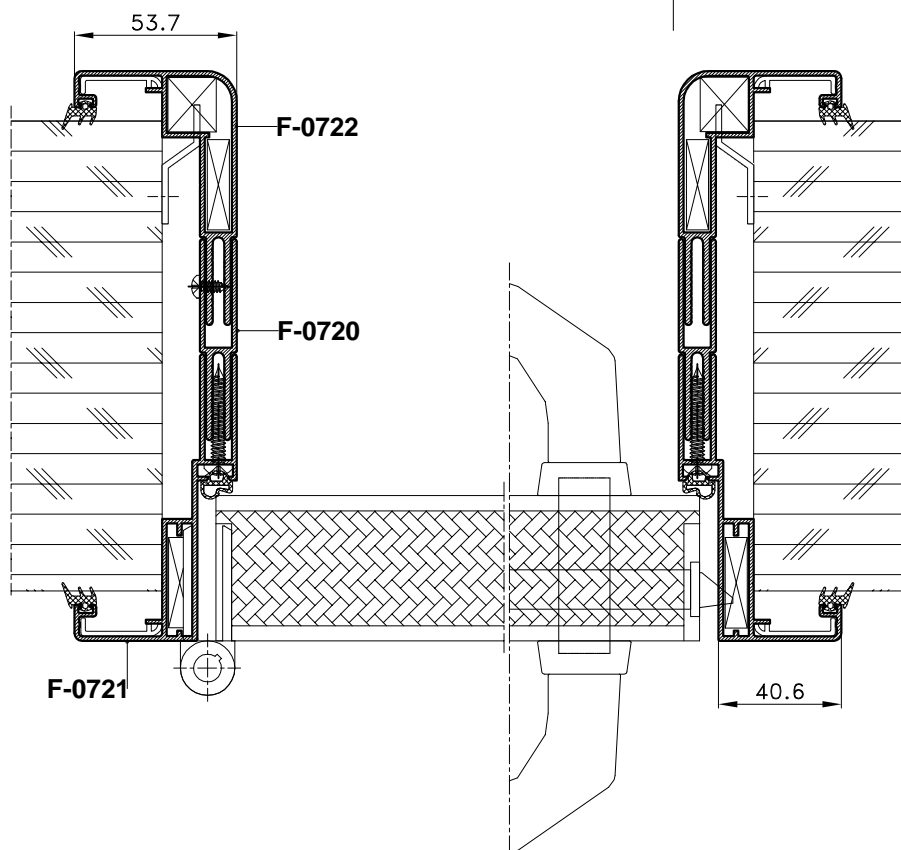
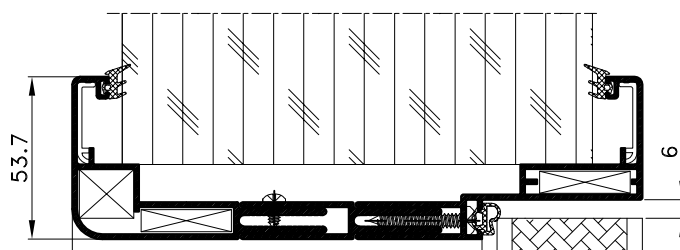

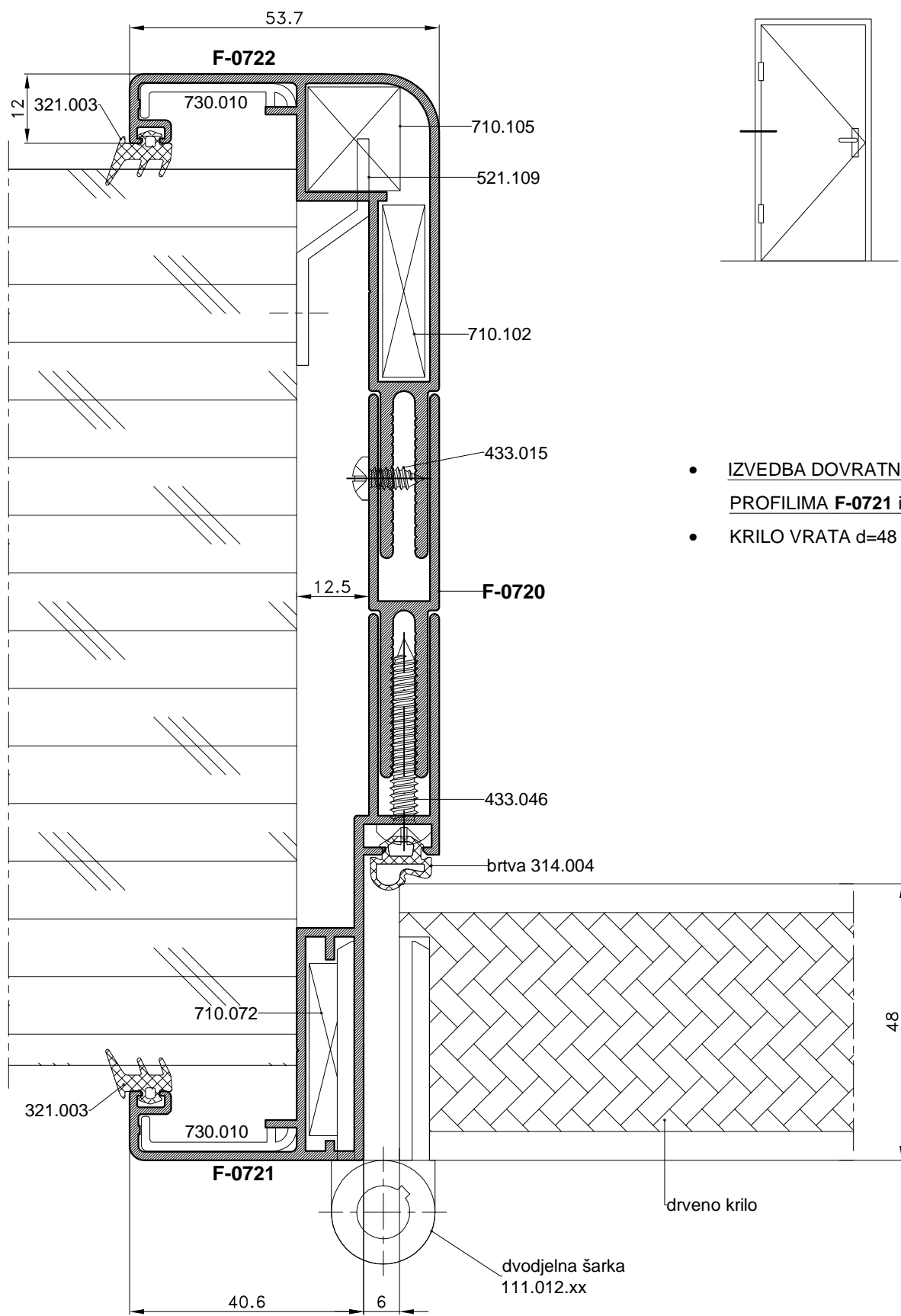

- IZVEDBA DOVRATNIKA S PROFILIMA F-0721 i F-722
- KRILO VRATA d=48 mm

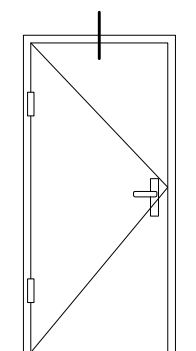

- IZVEDBA DOVRATNIKA S
PROFILIMA **F-0721** i **F-0722**
- Krilo vrata d=48 mm

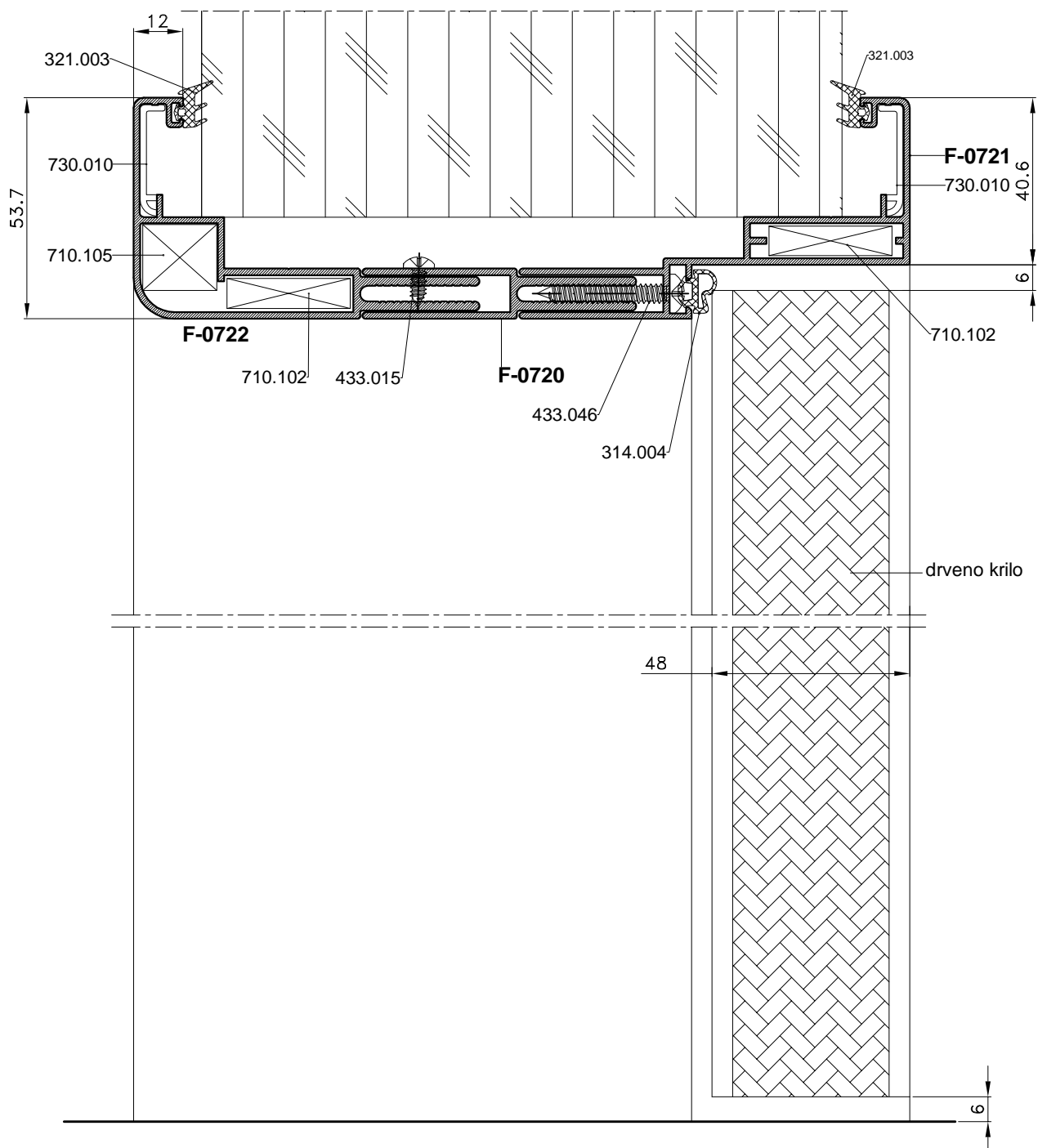

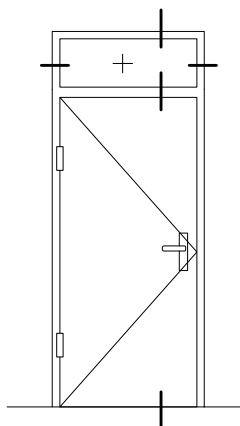

- IZVEDBA DOVRATNIKA S PROFILIMA **F-0721** i **F-0722**
- Krilo vrata d=48 mm
- FIKSNI DIO U NADSVJETLU

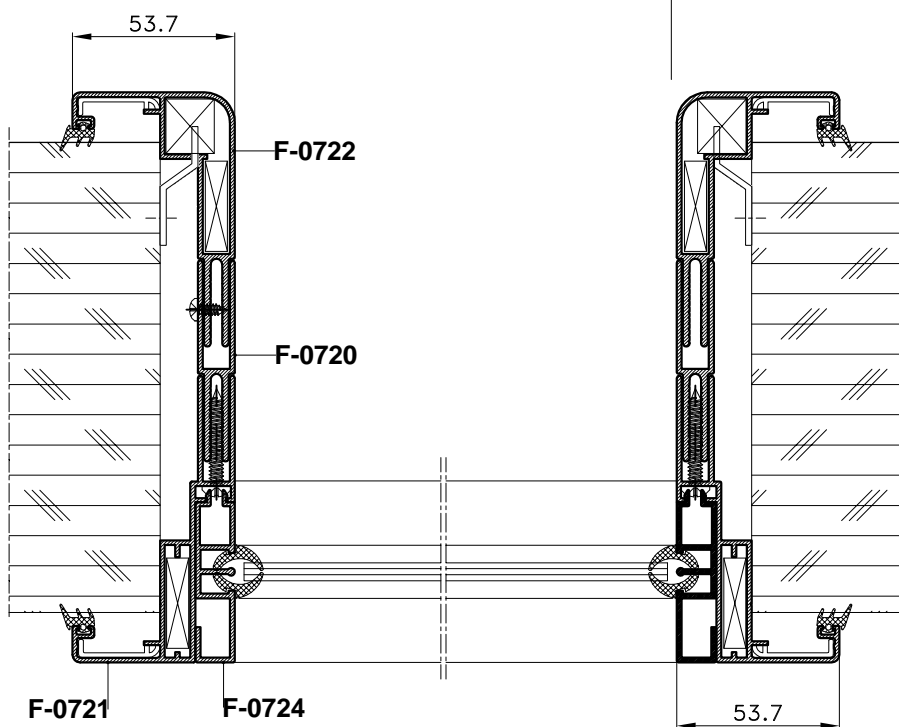
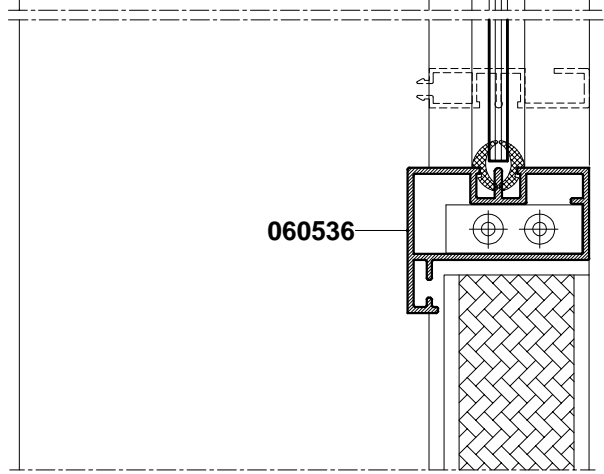
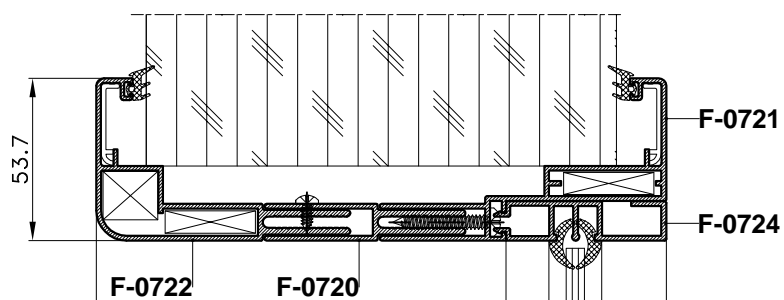

DETALJ PREČKE KOD VRATA S DRVENIM KRILOM I
FIKSNIM DIJELOM U NADSVJETLU

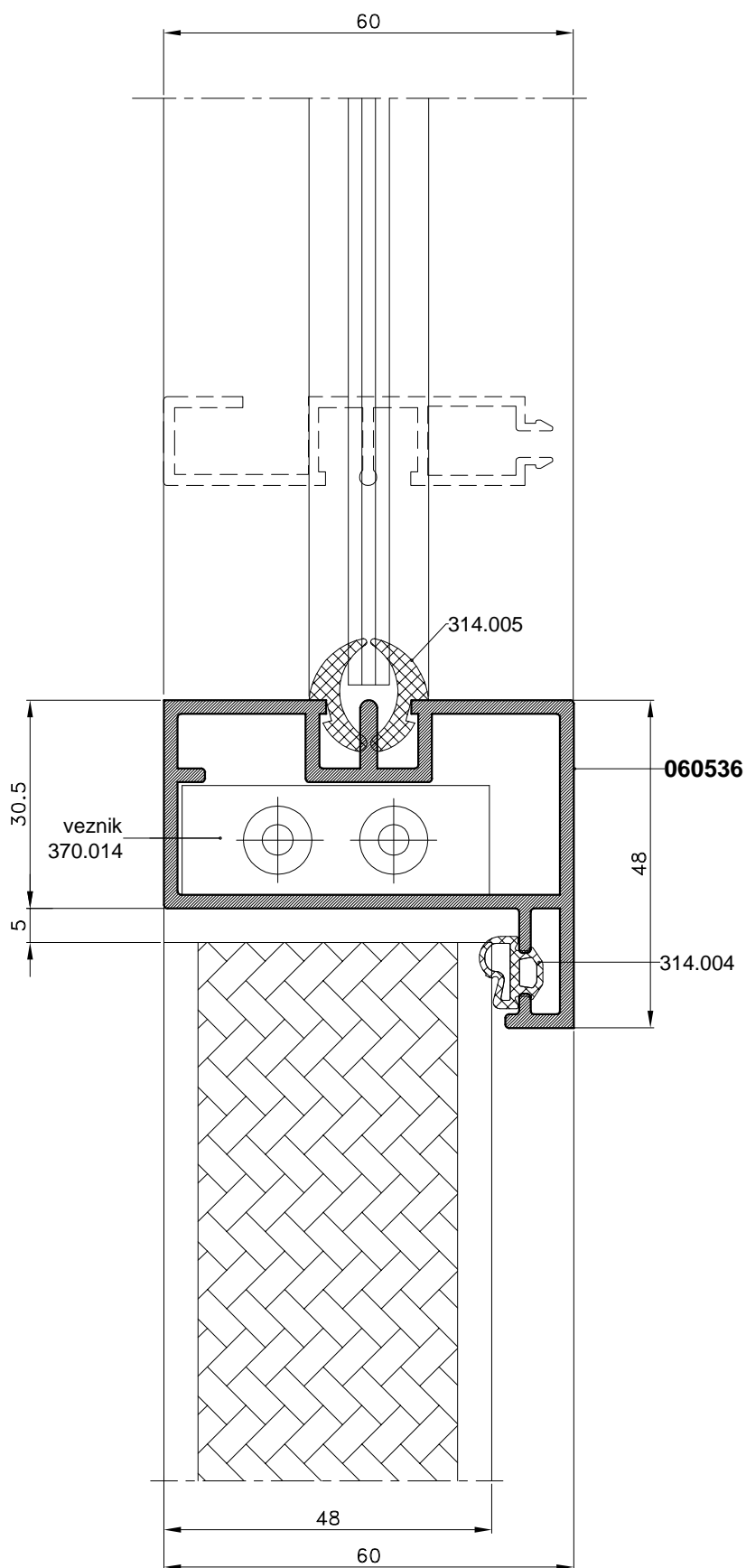
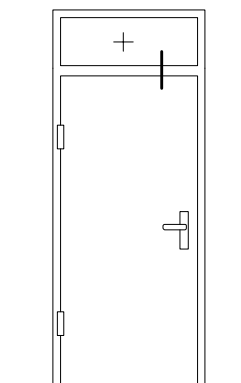

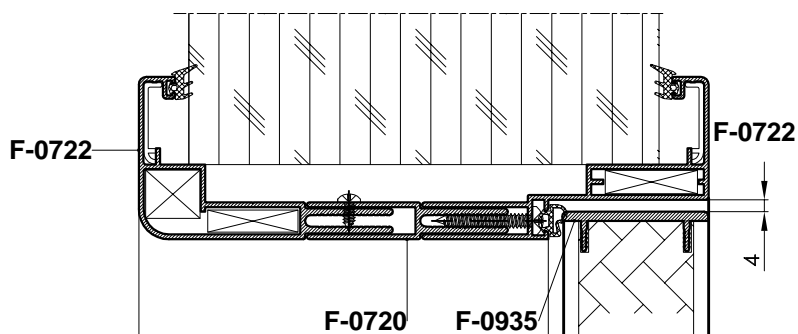
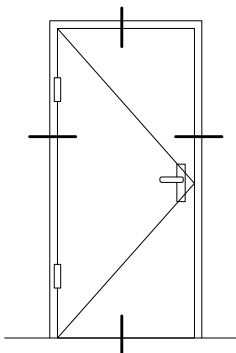

- IZVEDBA DRVENOG KRILA VRATA S
AL. PROFILOM F-0935 PO OPSEGU
- Krilo vrata d=48 mm

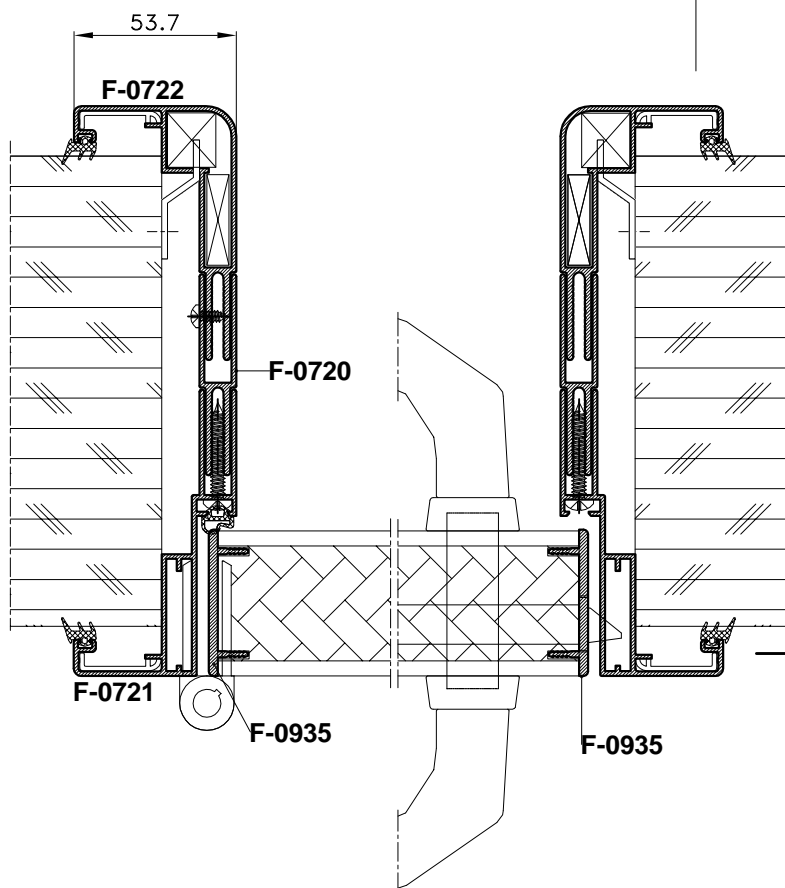

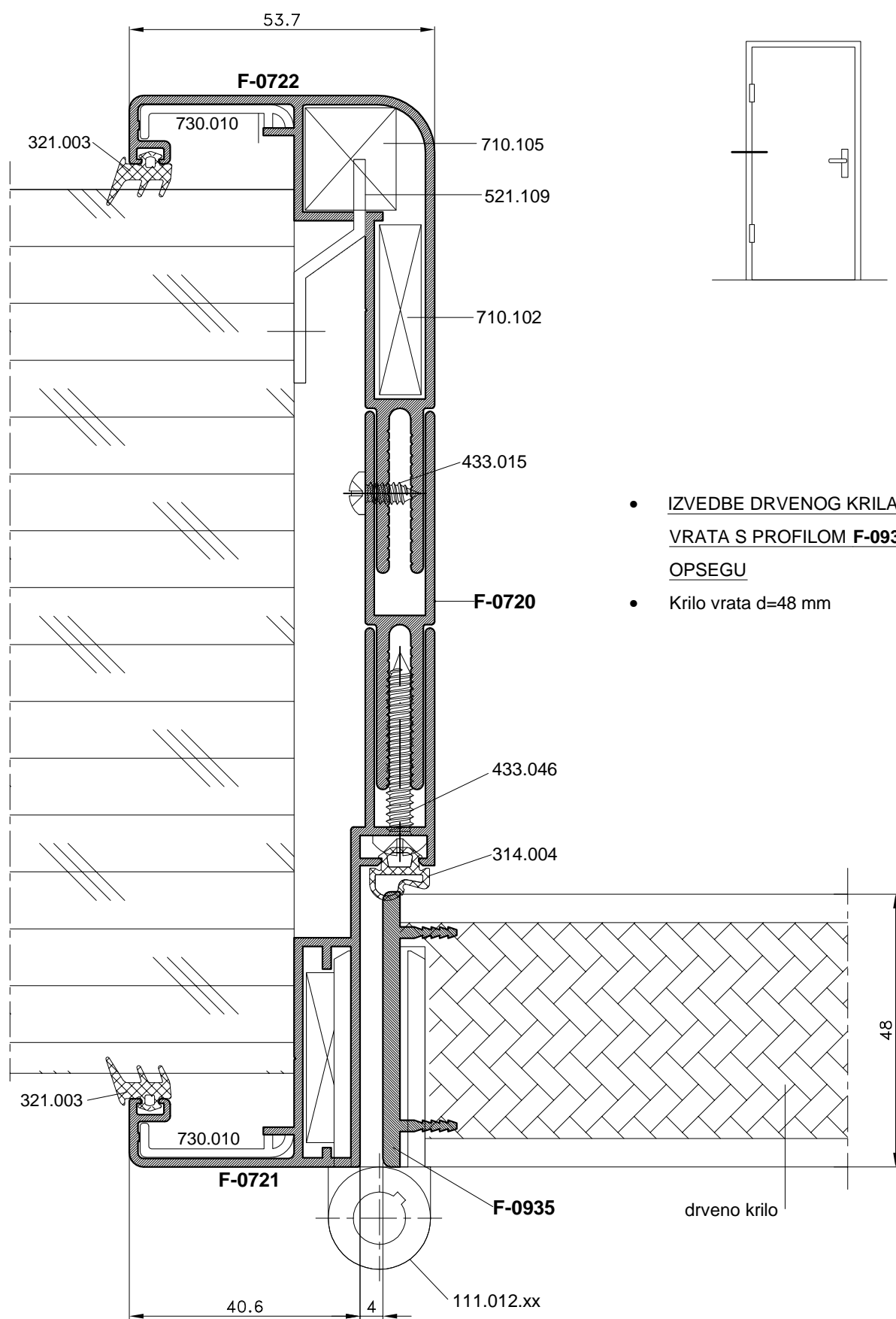

- IZVEDBE DRVENOG KRILA
- VRATA S PROFILOM F-0935 PO
- OPSEGU
- Krilo vrata d=48 mm

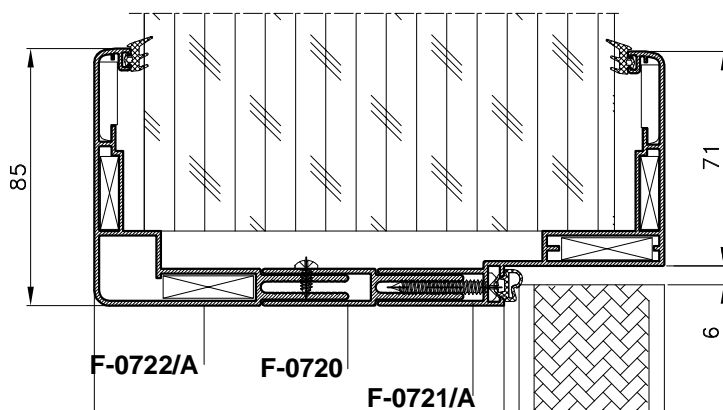
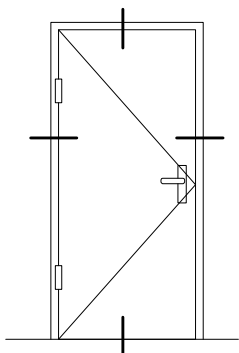

- IZVEDBA DOVRATNIKA S PROFILIMA F-0721/A i F-722/A
- KRILO VRATA d=48 mm

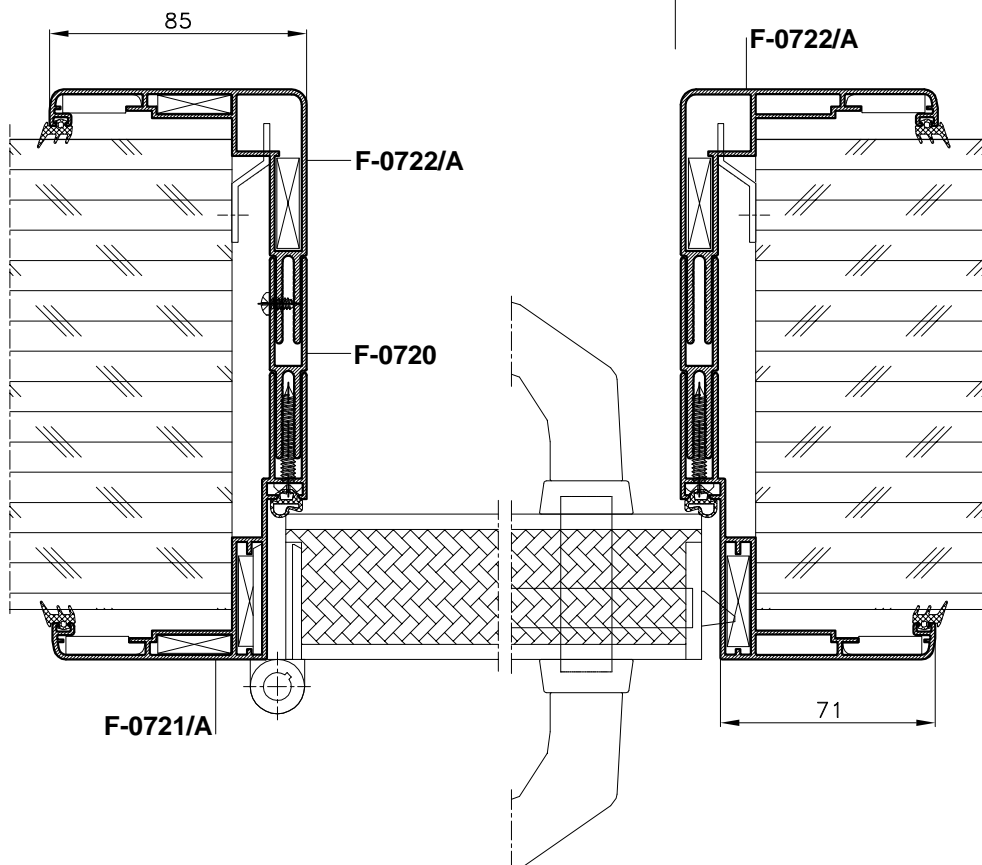

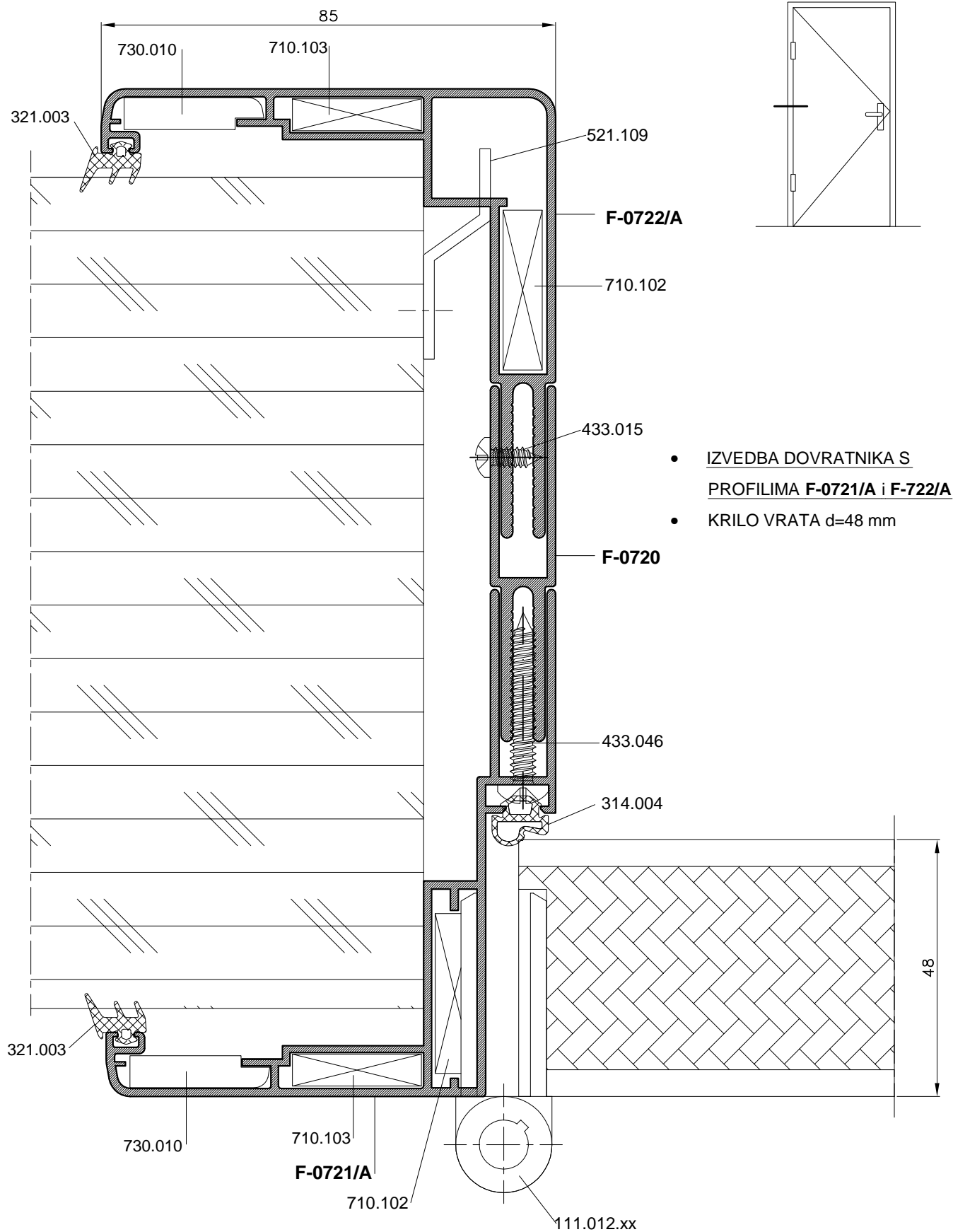

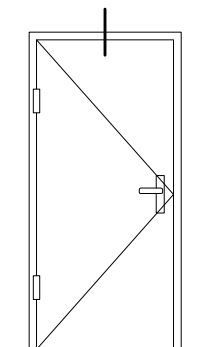

- IZVEDBA DOVRATNIKA S
PROFILIMA F-0721/A i F-722/A
- KRILO VRATA d=48 mm

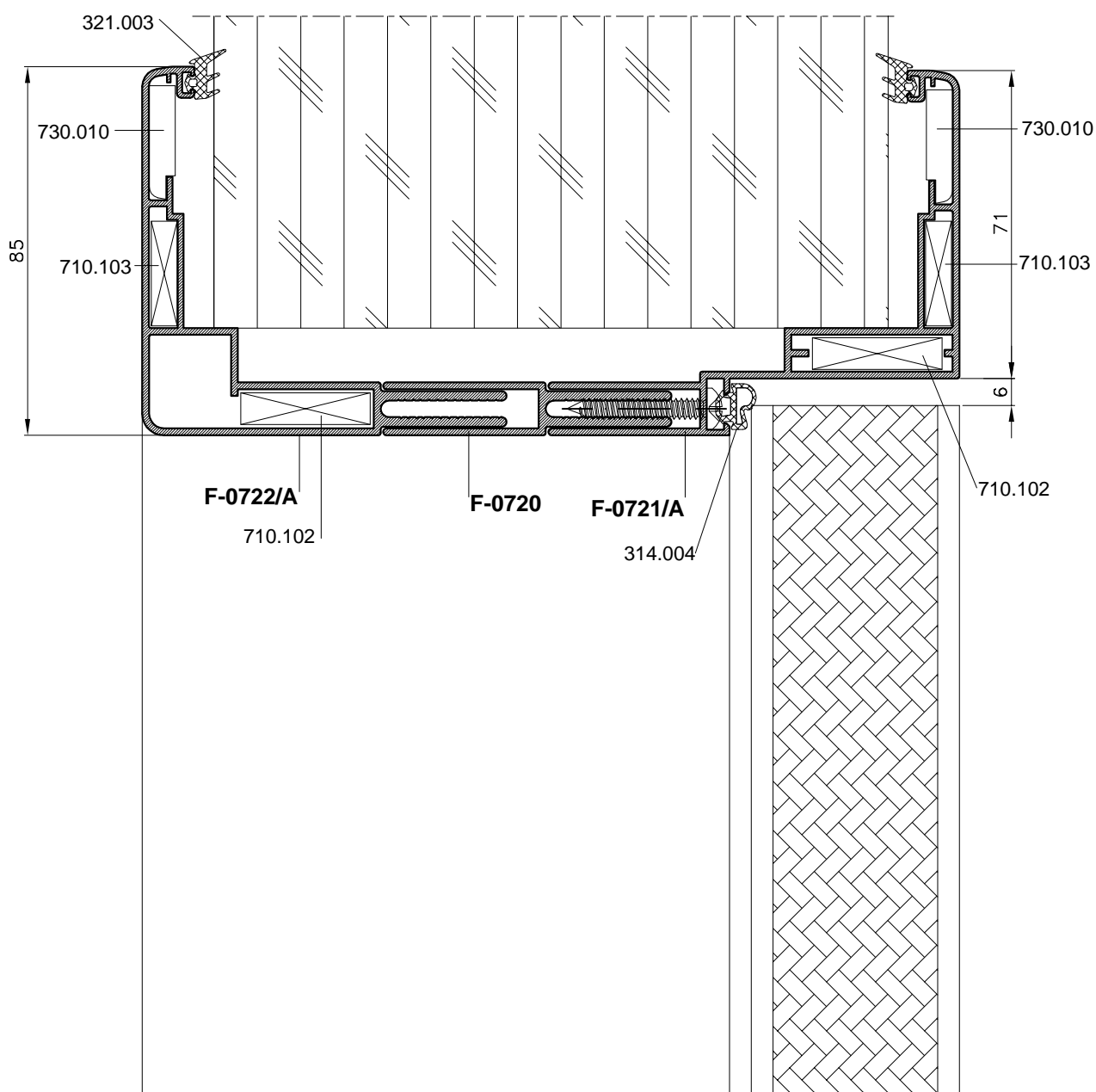

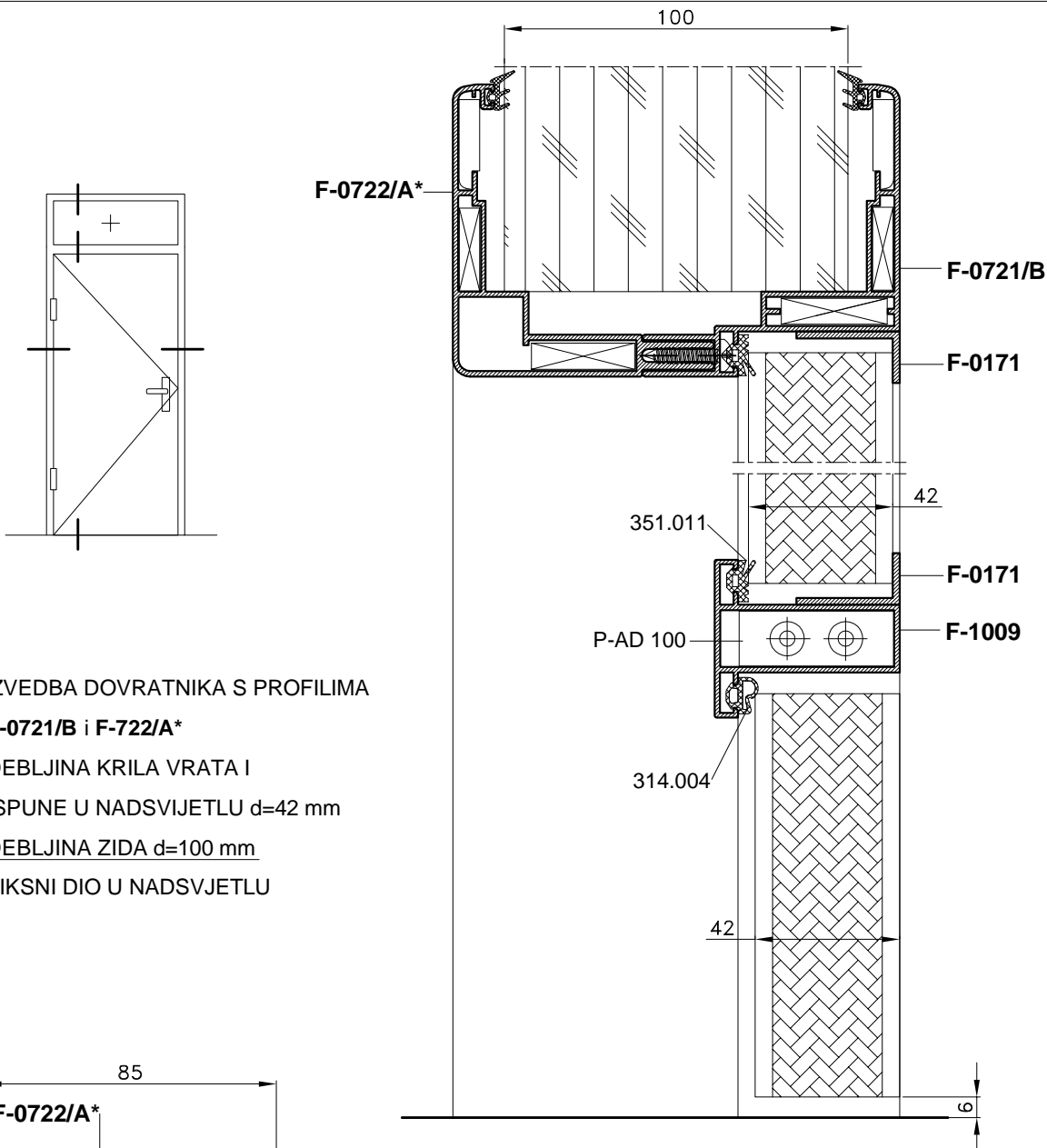

- IZVEDBA DOVRATNIKA S PROFILIMA **F-0721/B** i **F-722/A***
- DEBLJINA KRILA VRATA I
ISPUNE U NADSVIJETLU d=42 mm
- DEBLJINA ZIDA d=100 mm
- FIKSNI DIO U NADSVJETLU

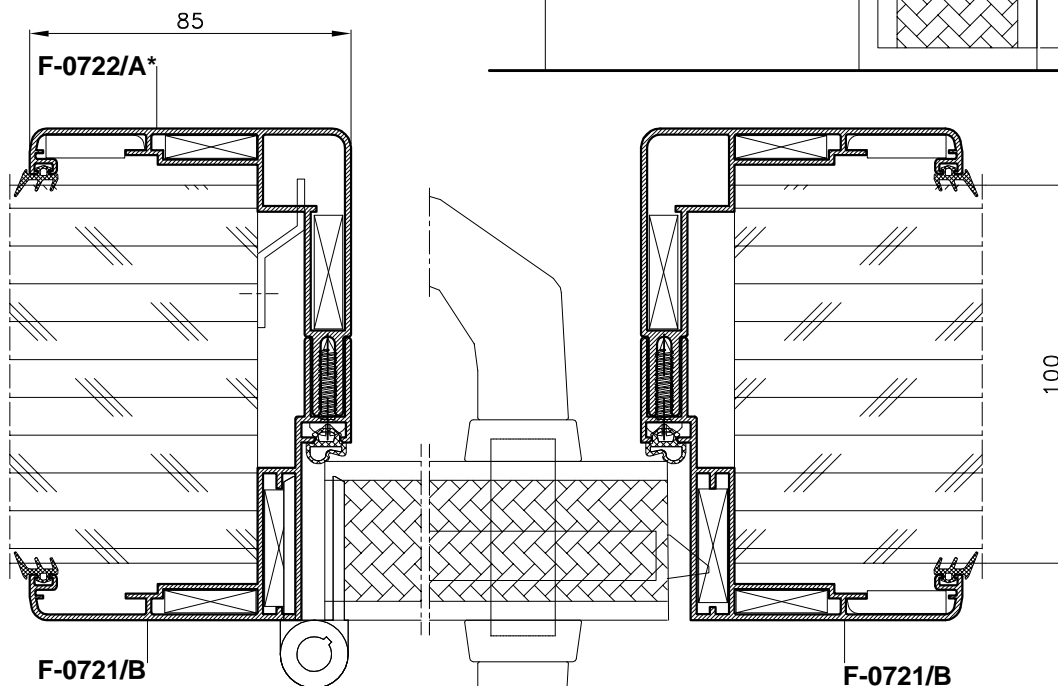

* postojeći profil F-0722/A se na alatu blokira prema crtežu

- IZVEDBA DOVRATNIKA S PROFILIMA **F-0721/B** i **F-722/A***
- DEBLJINA KRILA VRATA I
ISPUNE U NADSVIJETLU $d=42$ mm
- DEBLJINA ZIDA $d=100$ mm
- FIKSNI DIO U NADSVJETLU

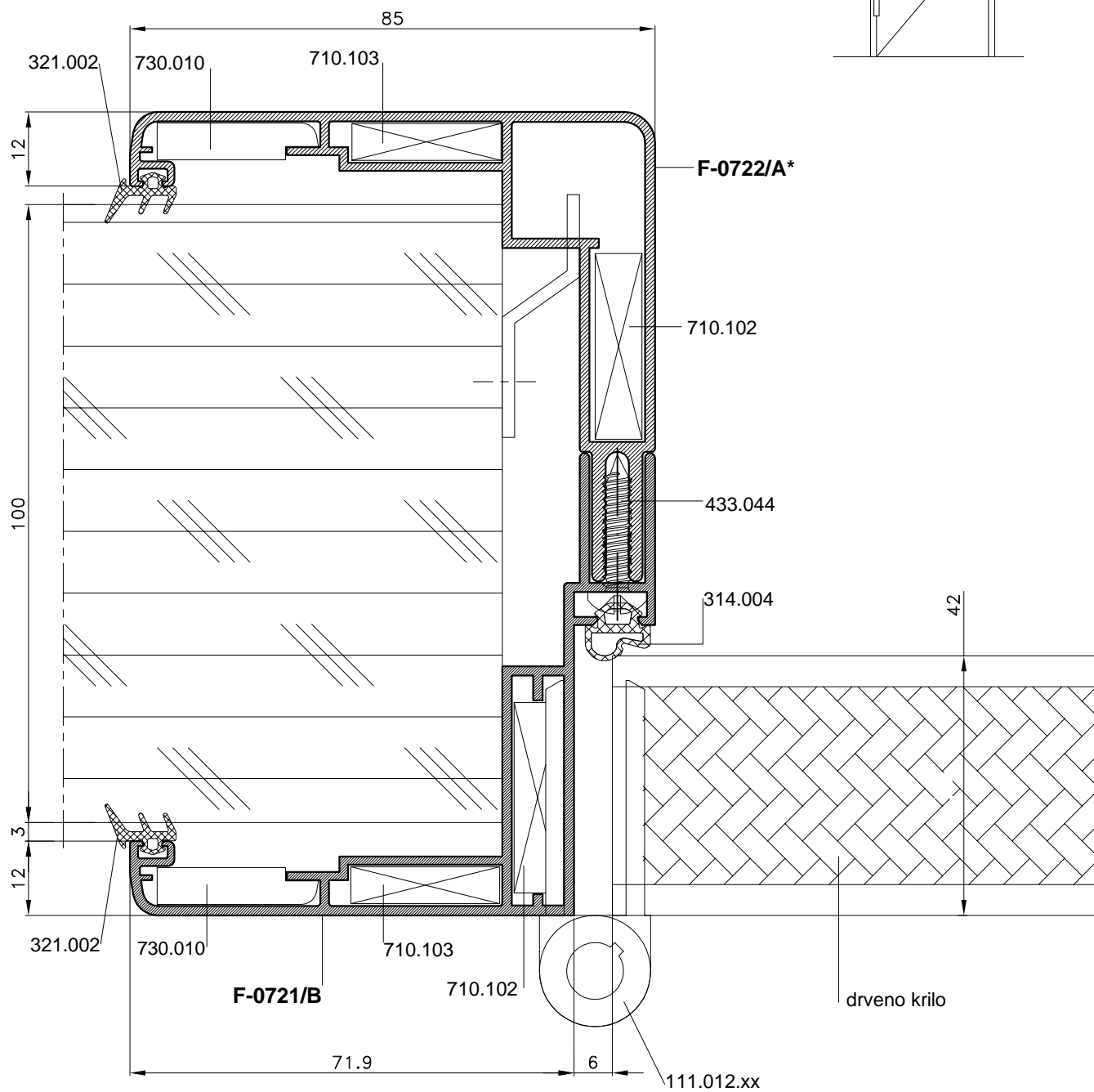
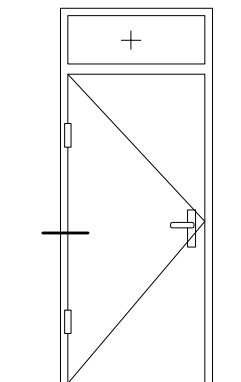

* postojeći profil F-0722/A se na alatu blokira prema crtežu

SNOP PROFILA U OVISNOSTI O DEBLJINI ZIDA

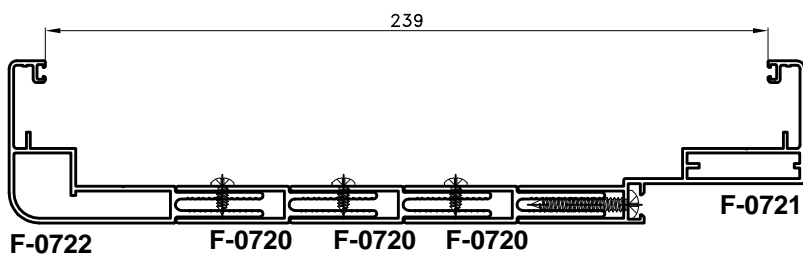
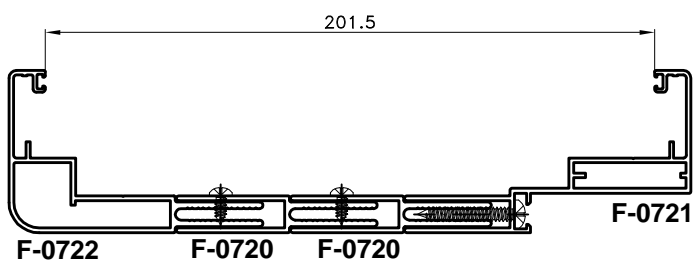
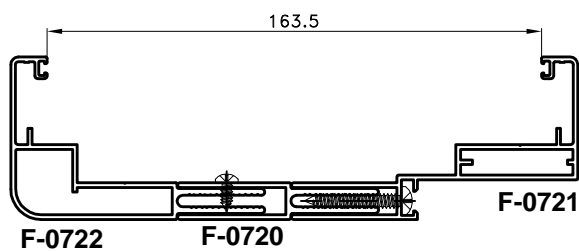
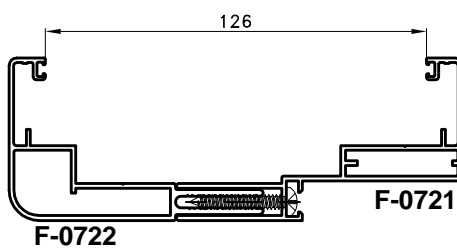
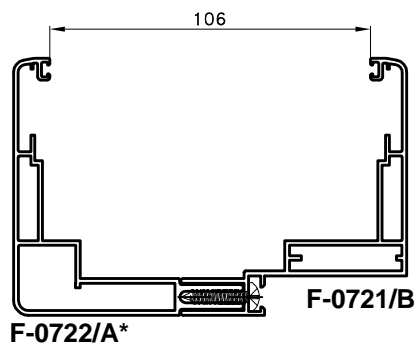

PRESJECI S ALUMINIJSKIM KRILOM

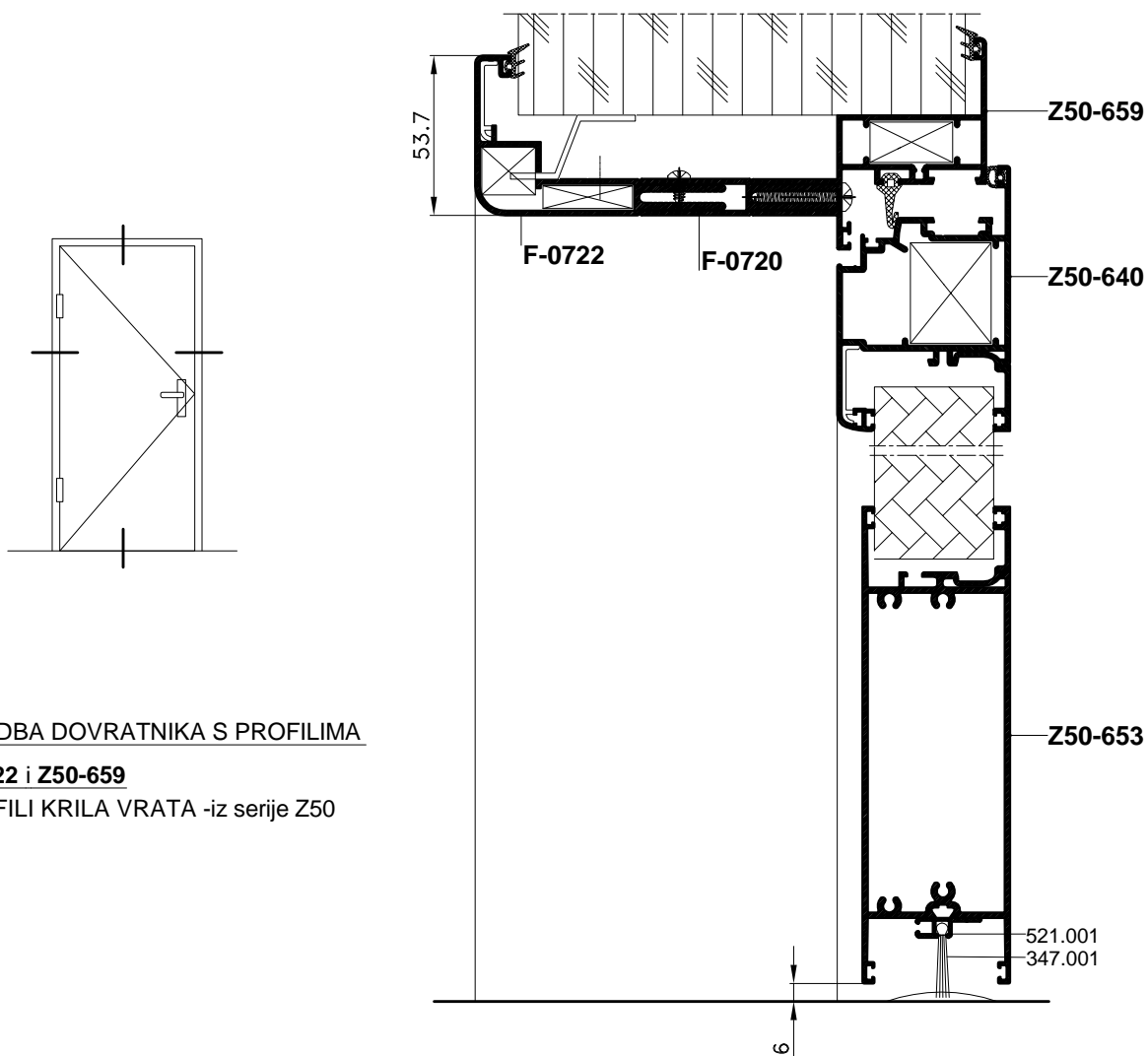

- IZVEDBA DOVRATNIKA S PROFILIMA
F-0722 i Z50-659
- PROFILI KRILA VRATA -iz serije Z50

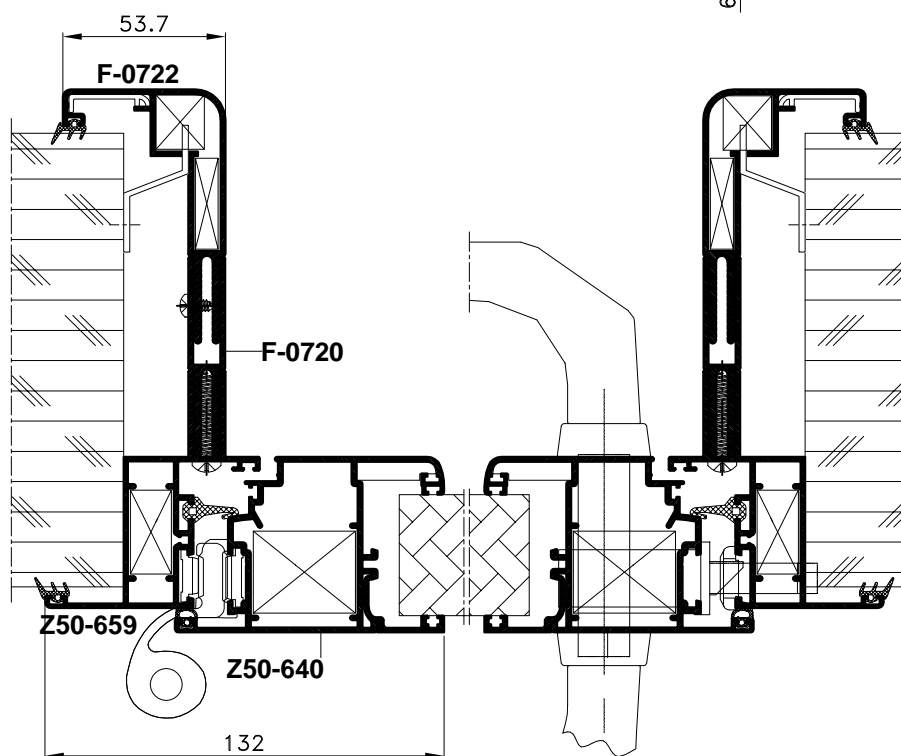

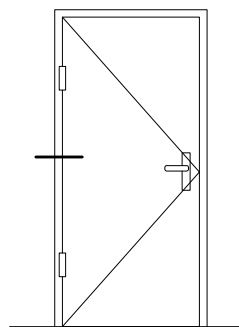
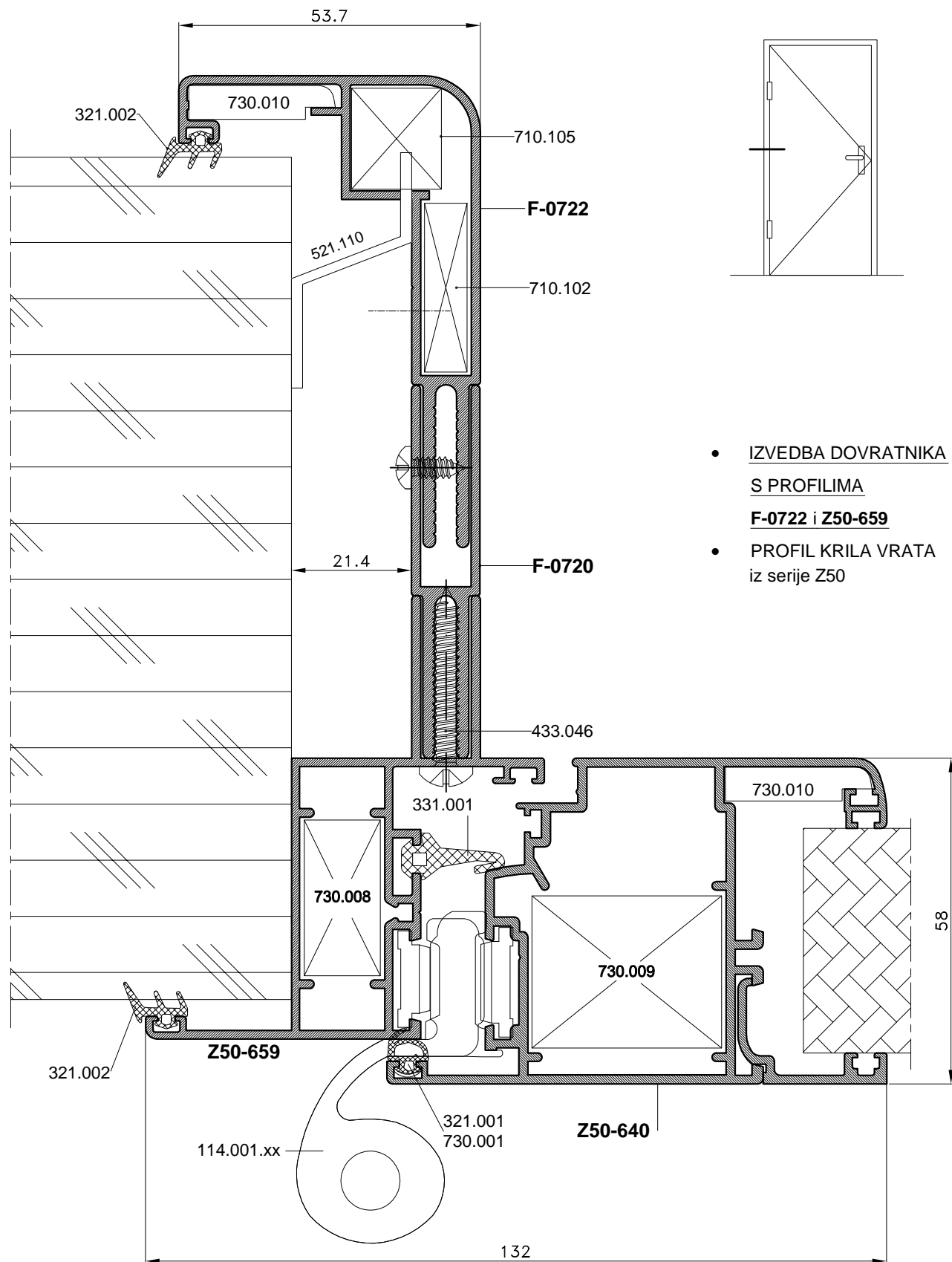

- IZVEDBA DOVRATNIKA S PROFILIMA F-0722 i Z50-659
- PROFIL KRILA VRATA iz serije Z50

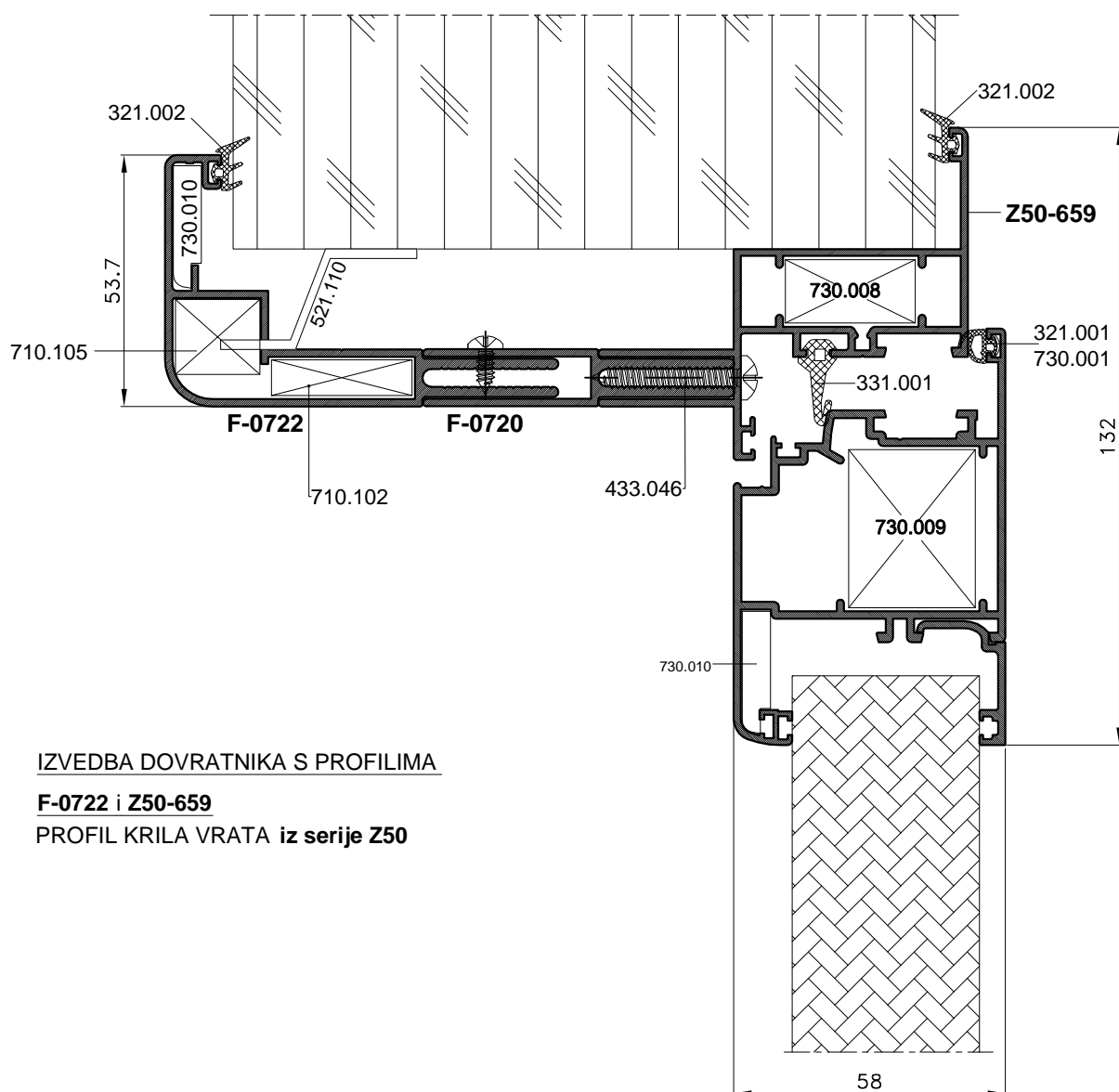
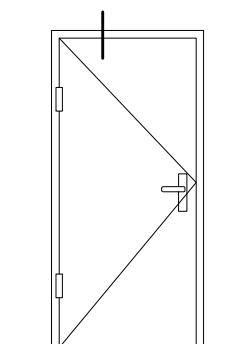

- IZVEDBA DOVRATNIKA S PROFILIMA
F-0722 i Z50-659
- **PROFIL KRILA VRATA iz serije Z50**

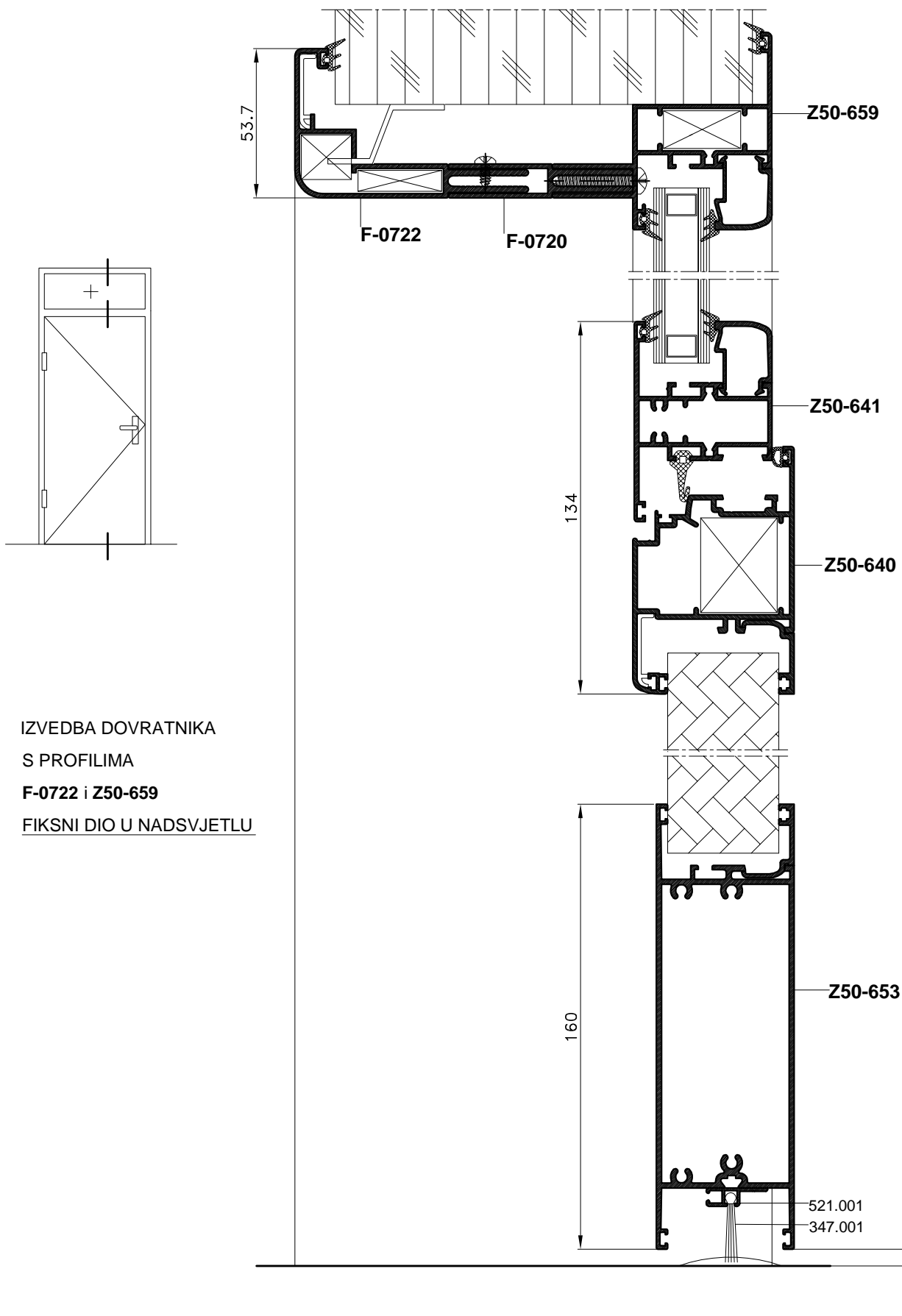

- IZVEDBA DOVRATNIKA S PROFILIMA F-0722 i Z50-659
- FIKSNI DIO U NADSVJETLU

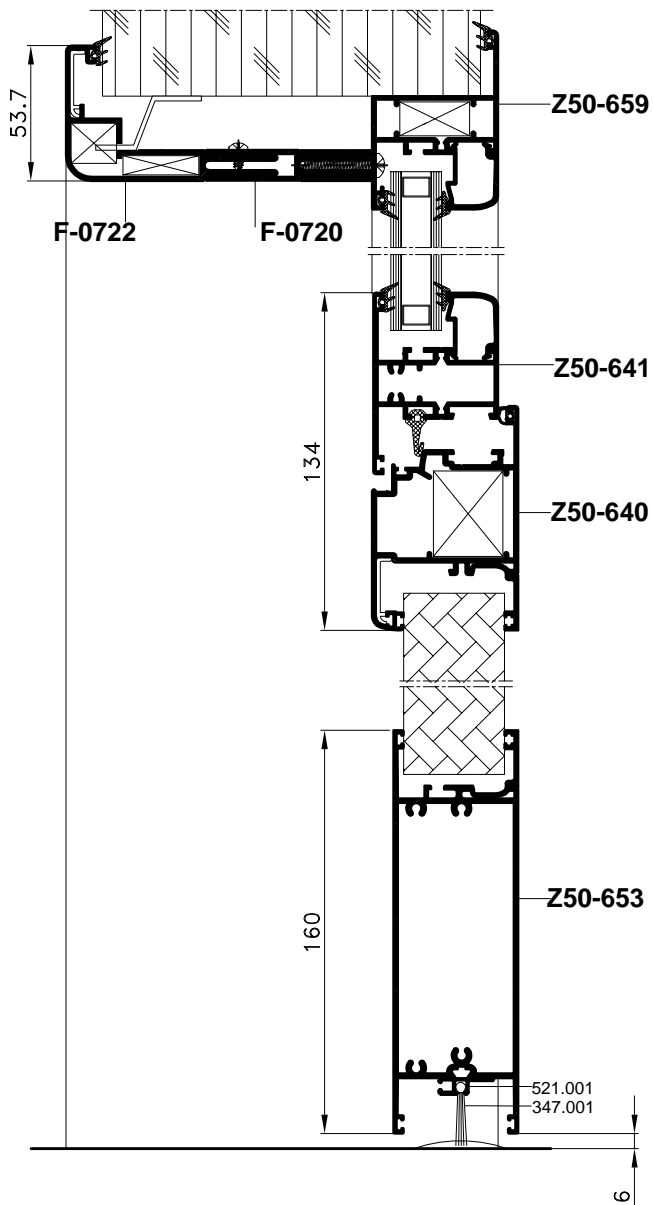
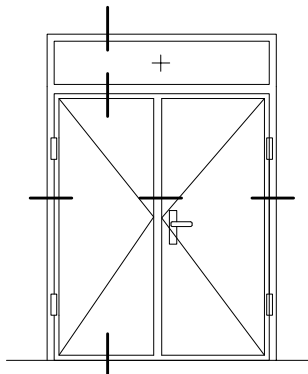

- IZVEDBA DOVRATNIKA S PROFILIMA **F-0722** i **Z50-659**
- DVOKRILNA VRATA
- FIKSNI DIO U NADSVJETLU

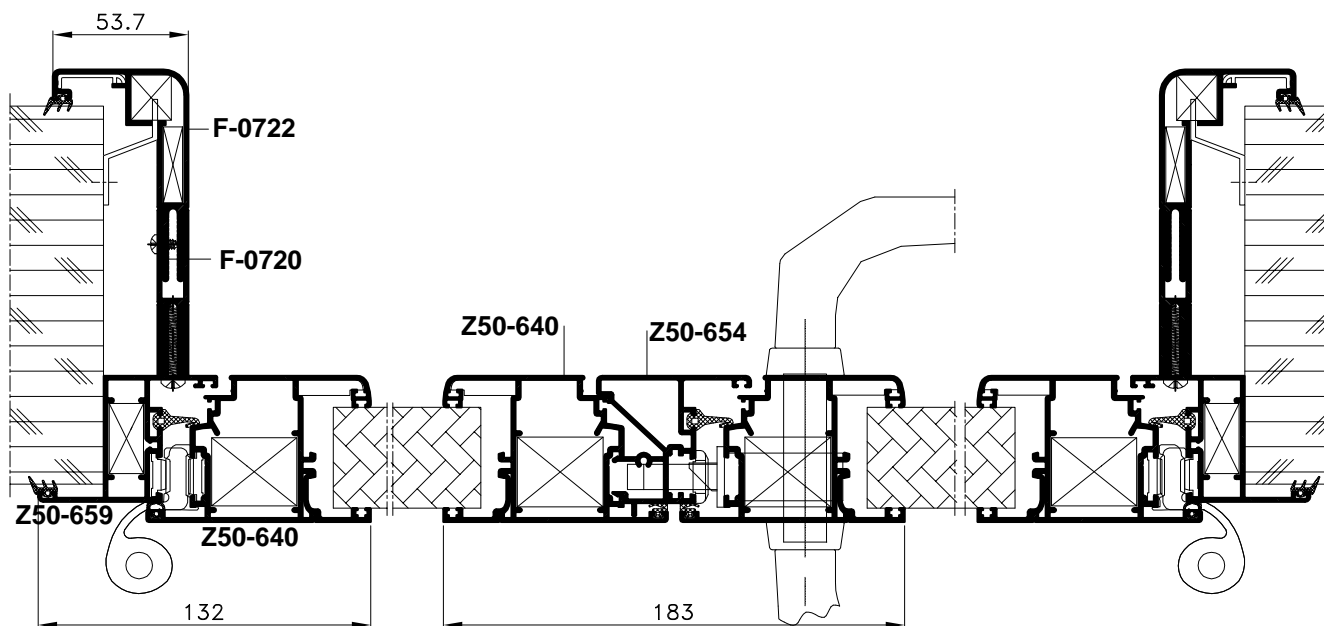

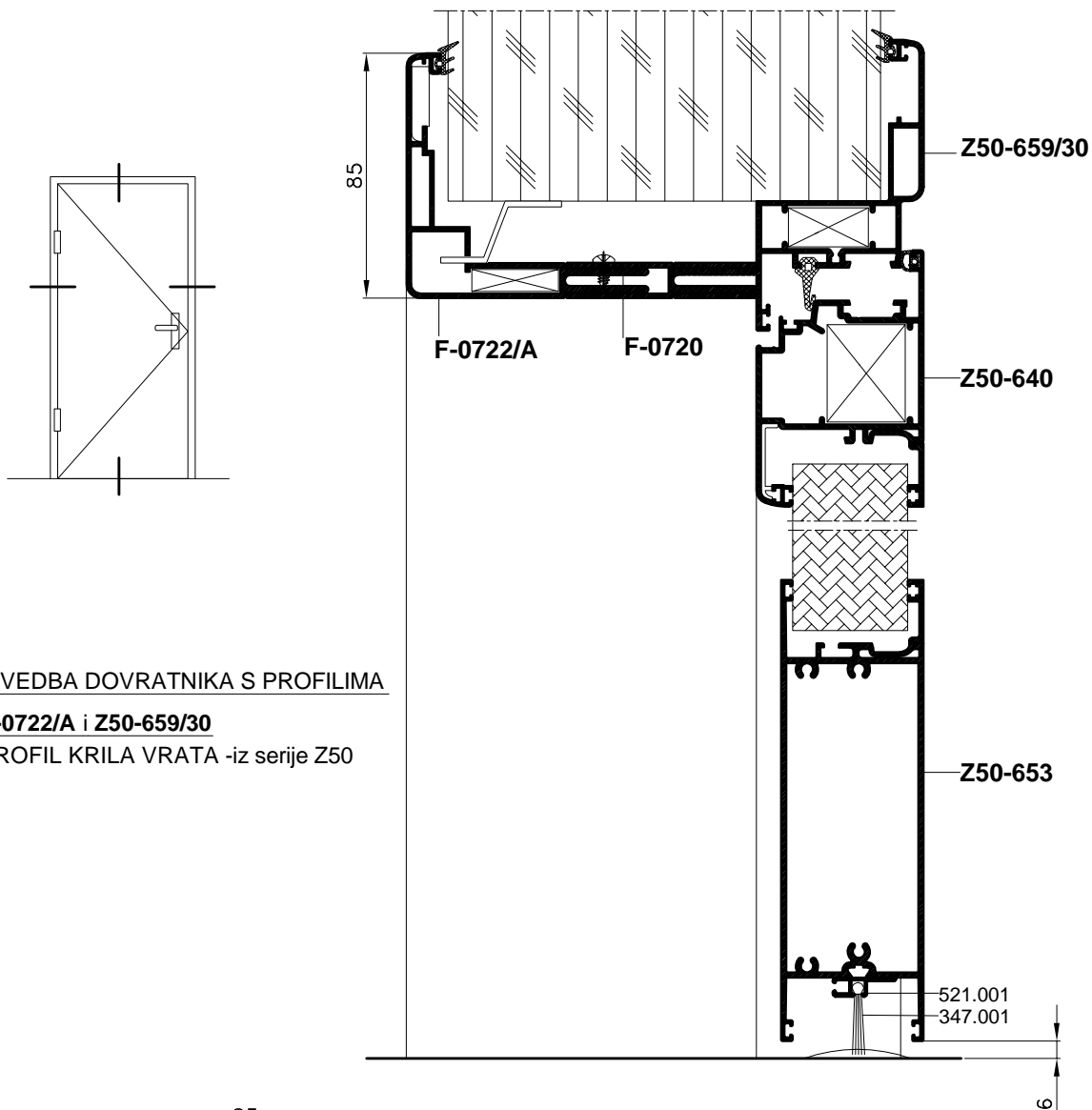

- IZVEDBA DOVRATNIKA S PROFILIMA

F-0722/A i Z50-659/30

- PROFIL KRILA VRATA -iz serije Z50

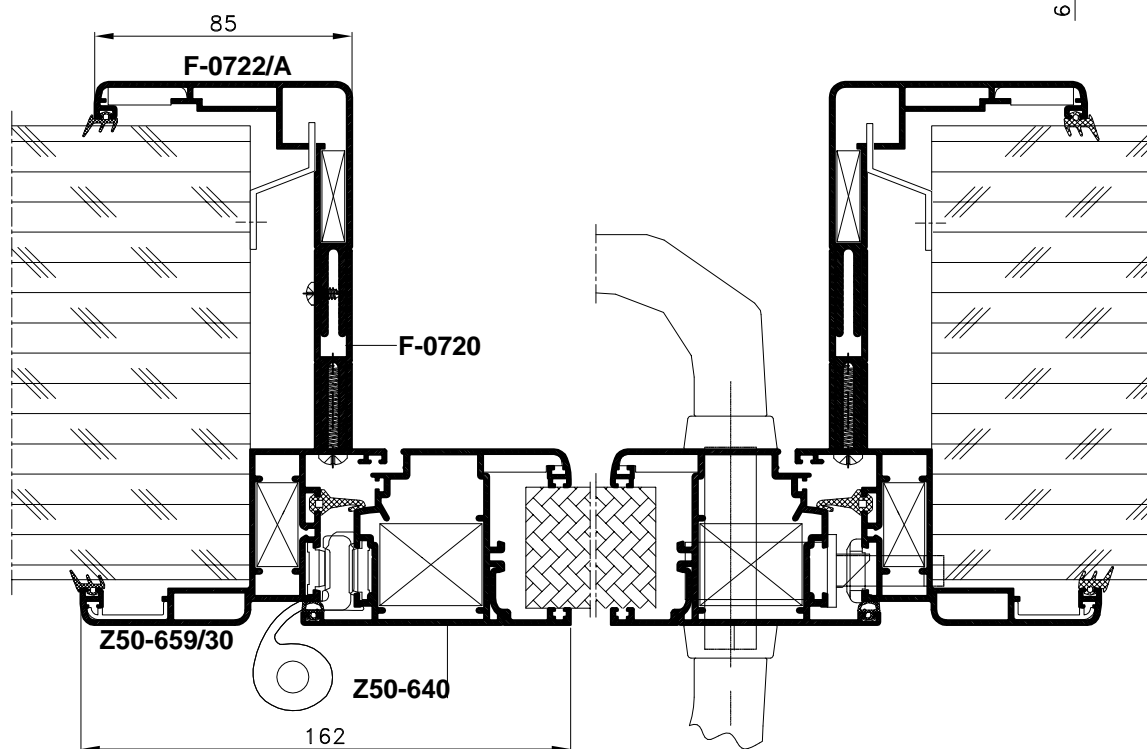

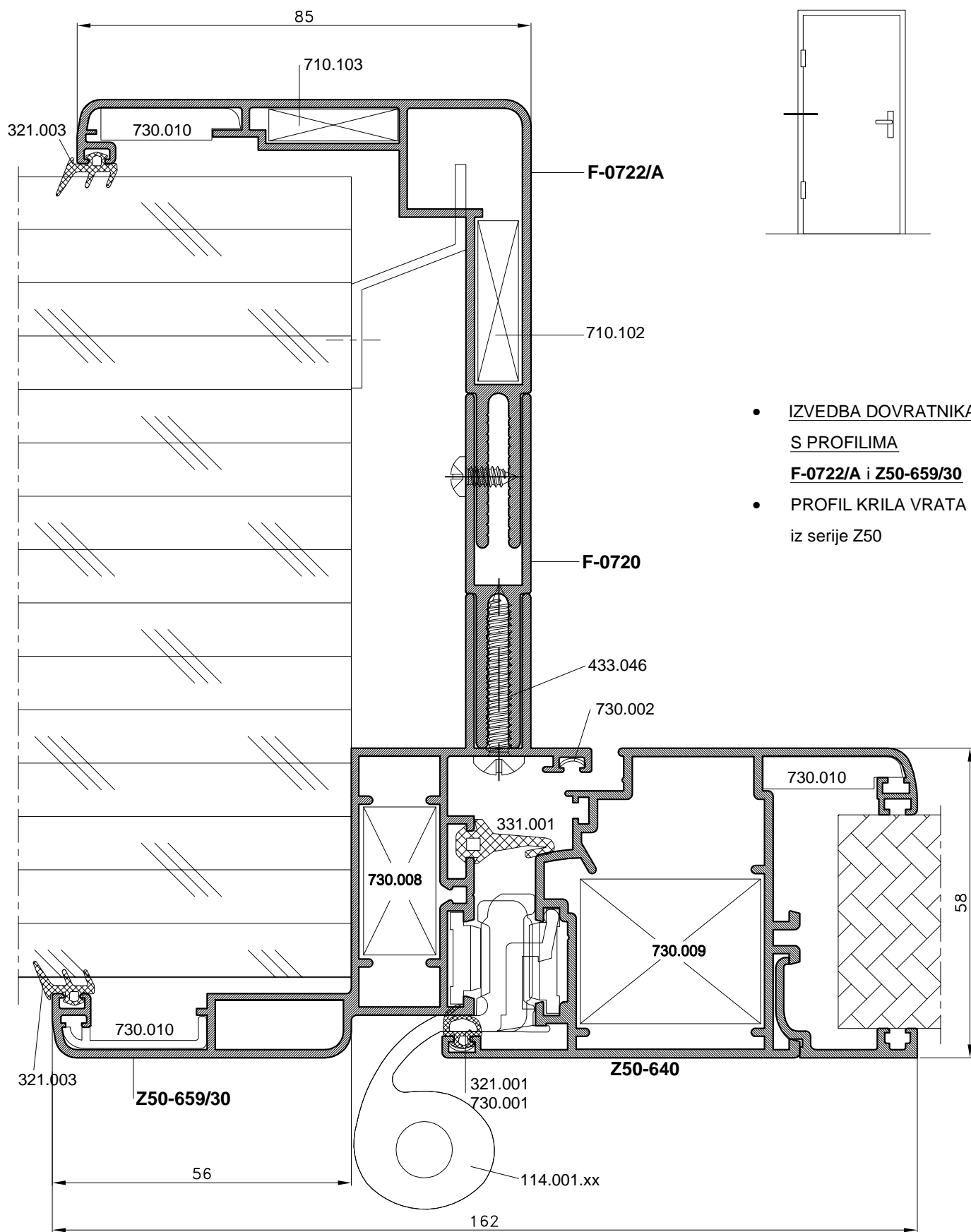

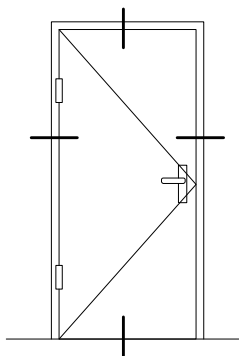

- IZVEDBA DOVRATNIKA
S PROFILIMA **F-0722/B** i **Z50-659**
- PROFIL KRILA VRATA **Z50-640** -iz serije Z50
- ZA DEBLJINU ZIDA 100 mm

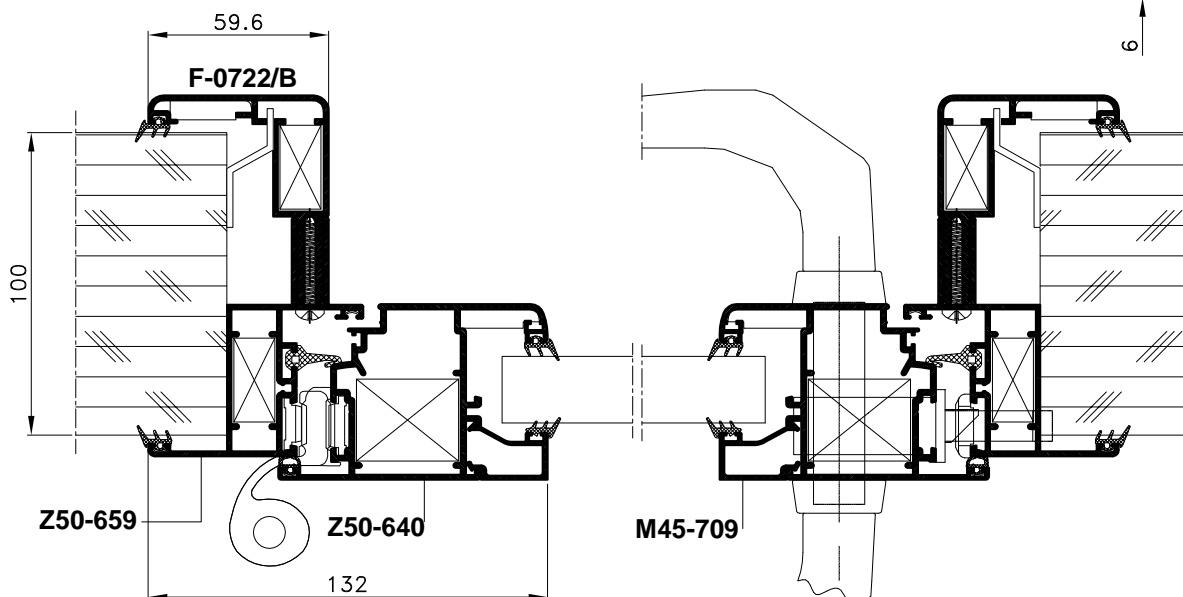
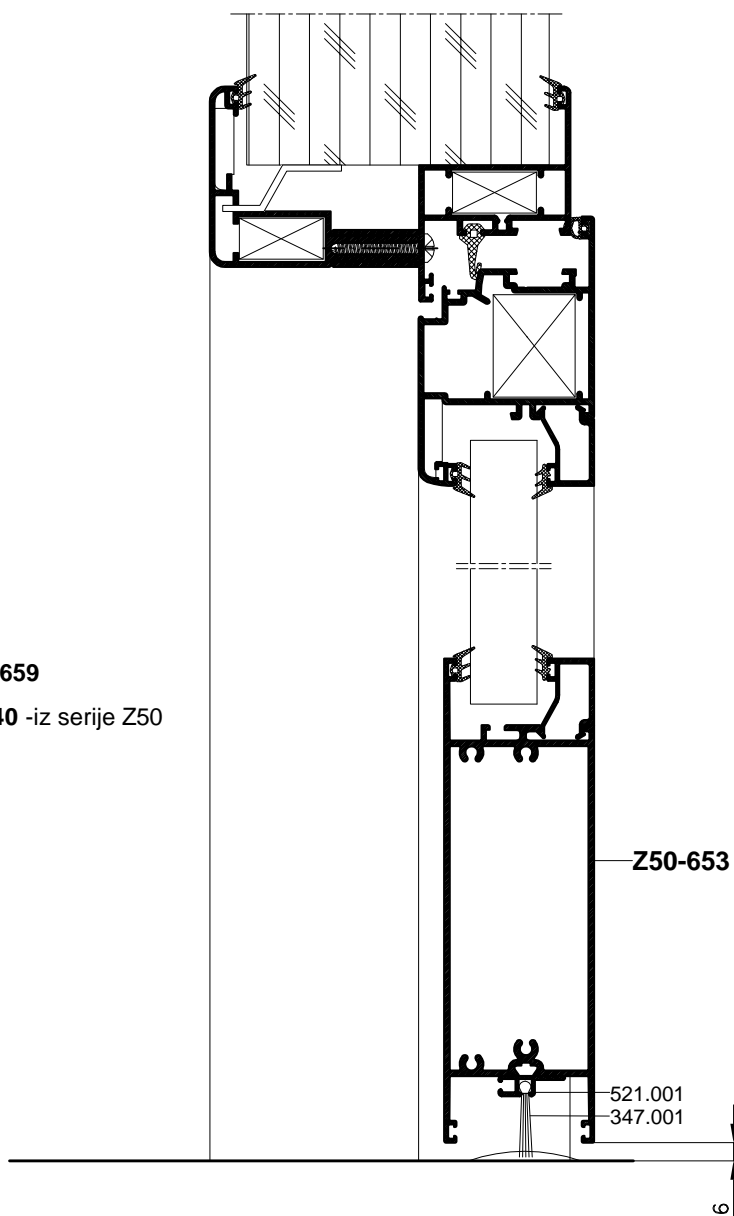

- IZVEDBA DOVRATNIKA
S PROFILIMA **F-0722/B** i **Z50-659**
- PROFIL KRILA VRATA **Z50-640** -iz serije Z50
- ZA DEBLJINU ZIDA 100 mm

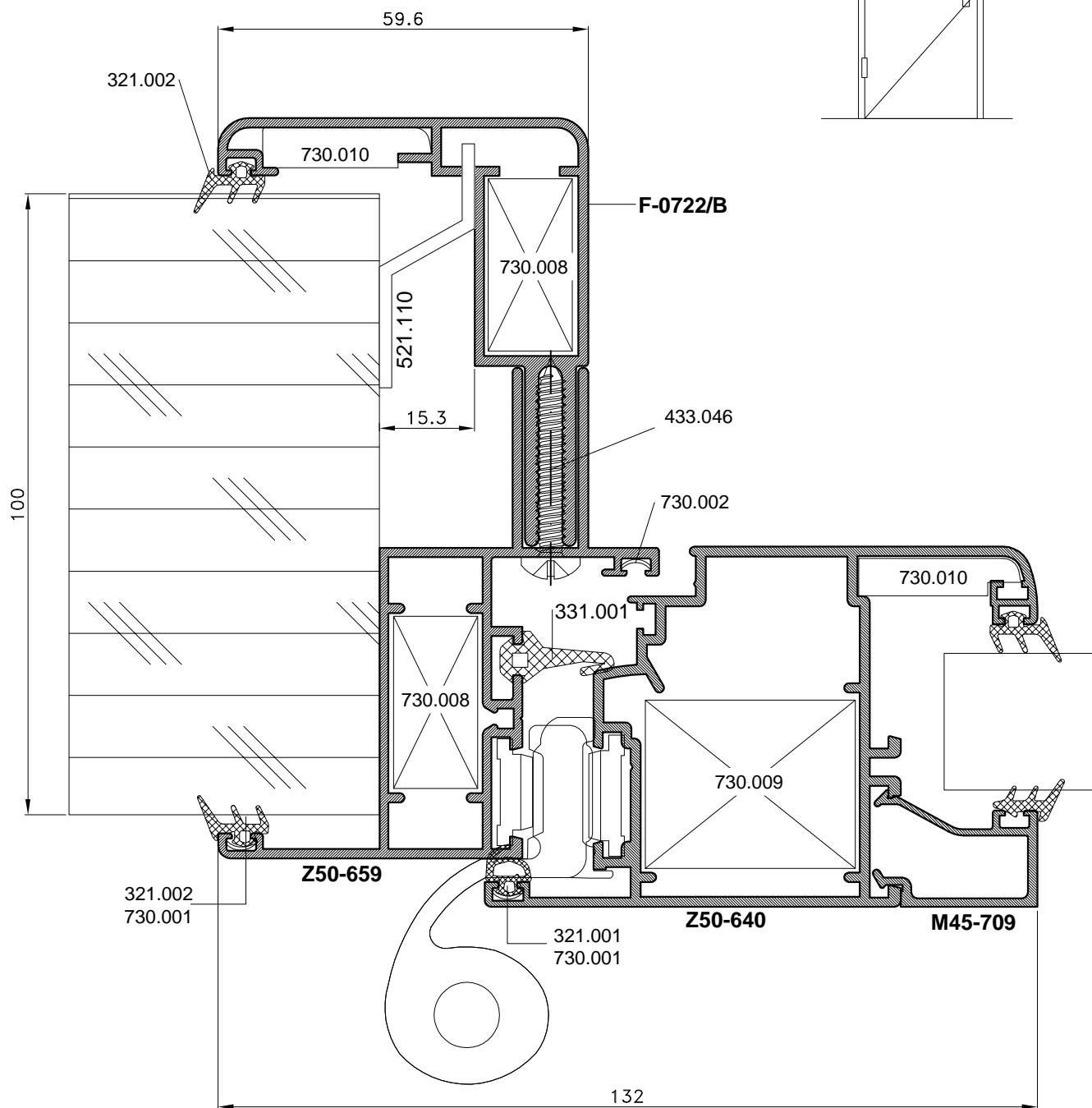
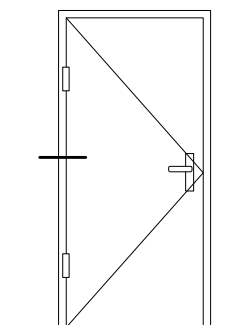

SNOP PROFILA U OVISNOSTI O DEBLJINI ZIDA

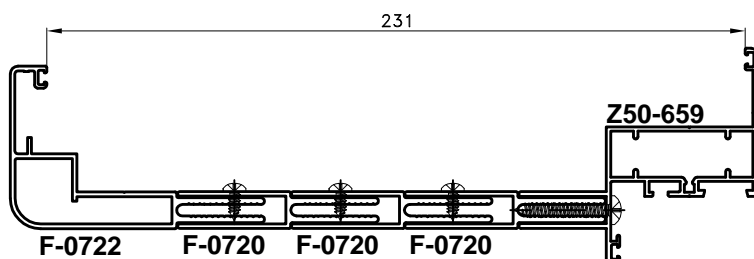
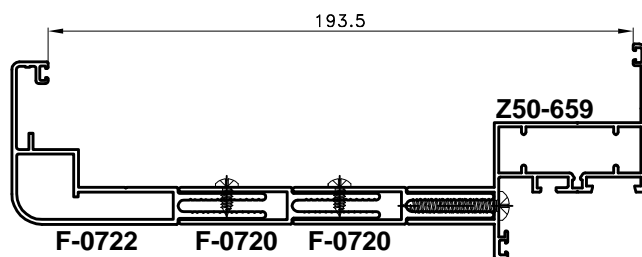
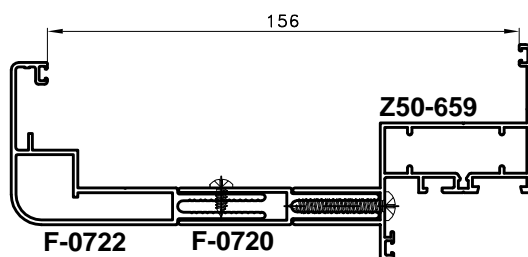
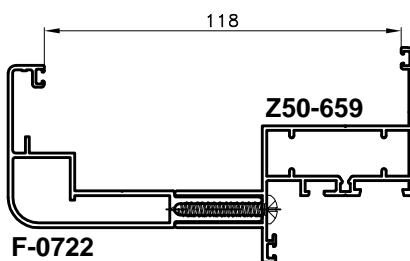
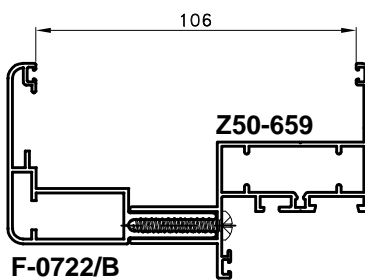

PRESJECI SA STAKLENIM I DRVENIM KRILOM
VRATA, BRAVOM HOPPE I SKRIVENOM ŠARKOM

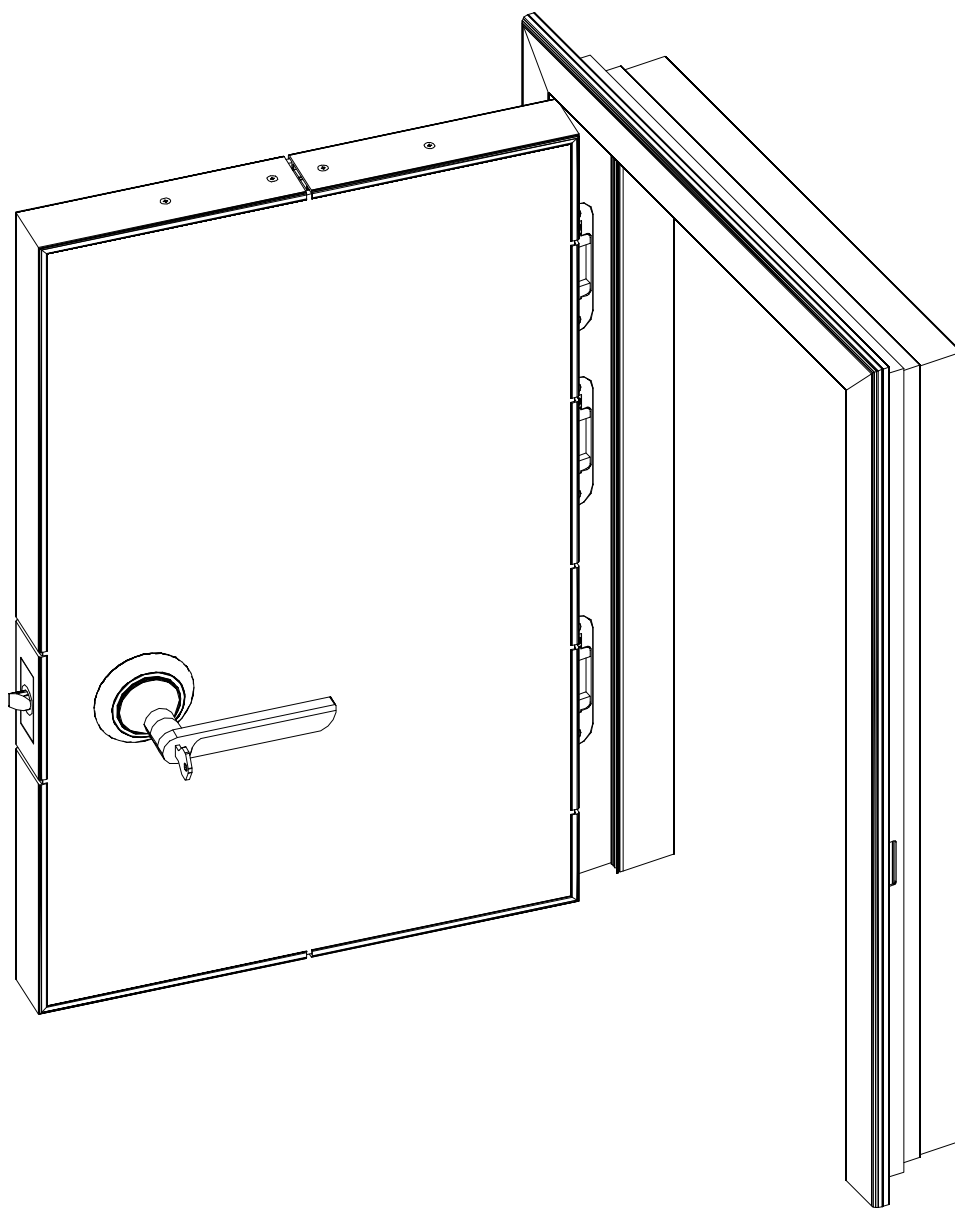

VRATA SA STAKLENIM KRILOM, BRAVOM HOPPE HCS I SKRIVENOM ŠARKOM

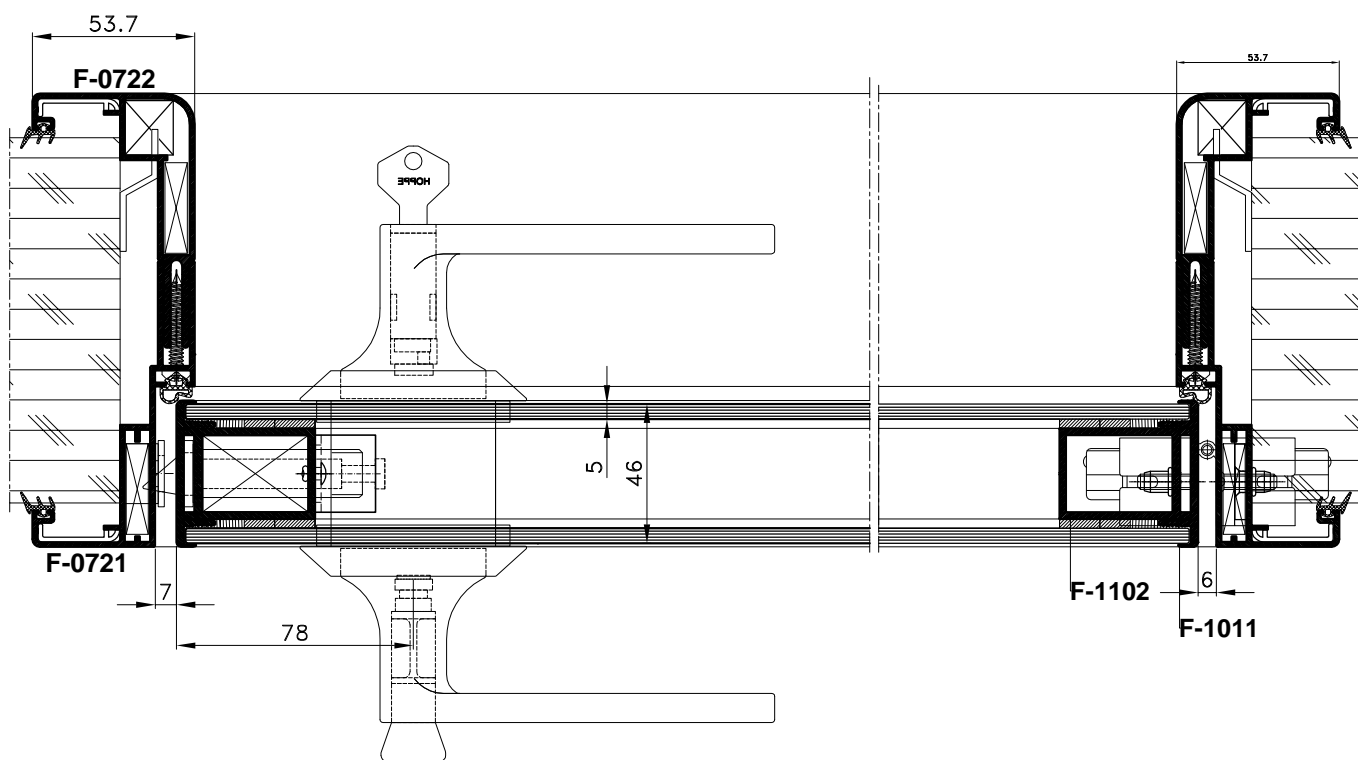
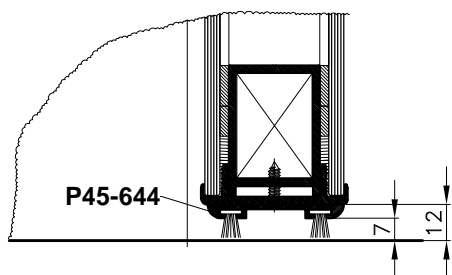
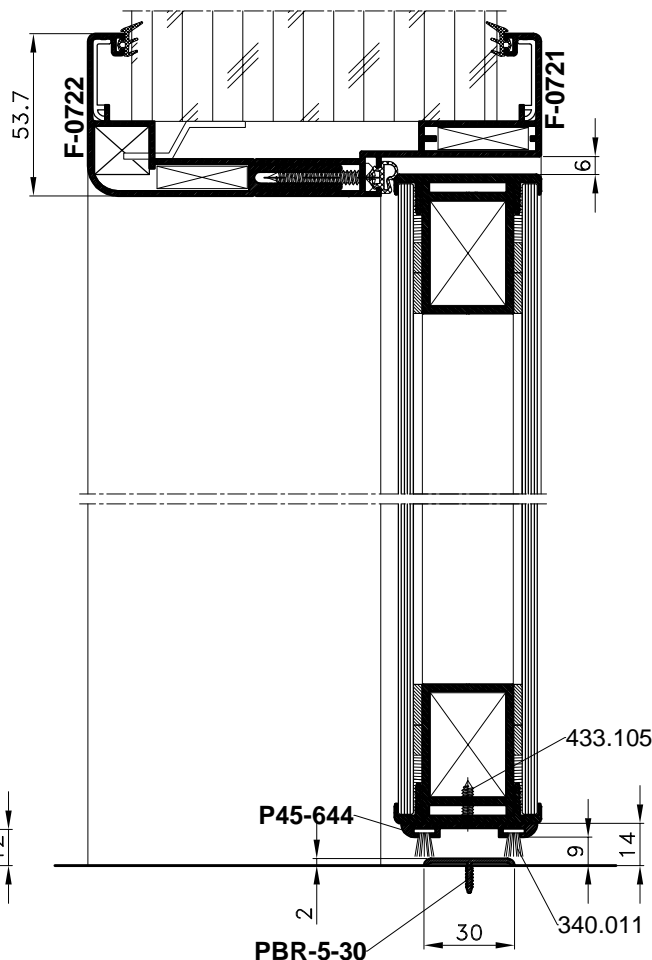
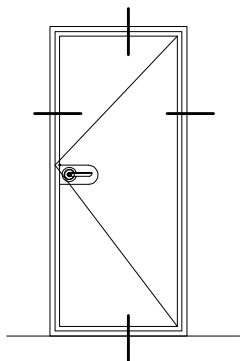

VRATA SA STAKLENIM KRILOM I BRAVOM HOPPE HCS

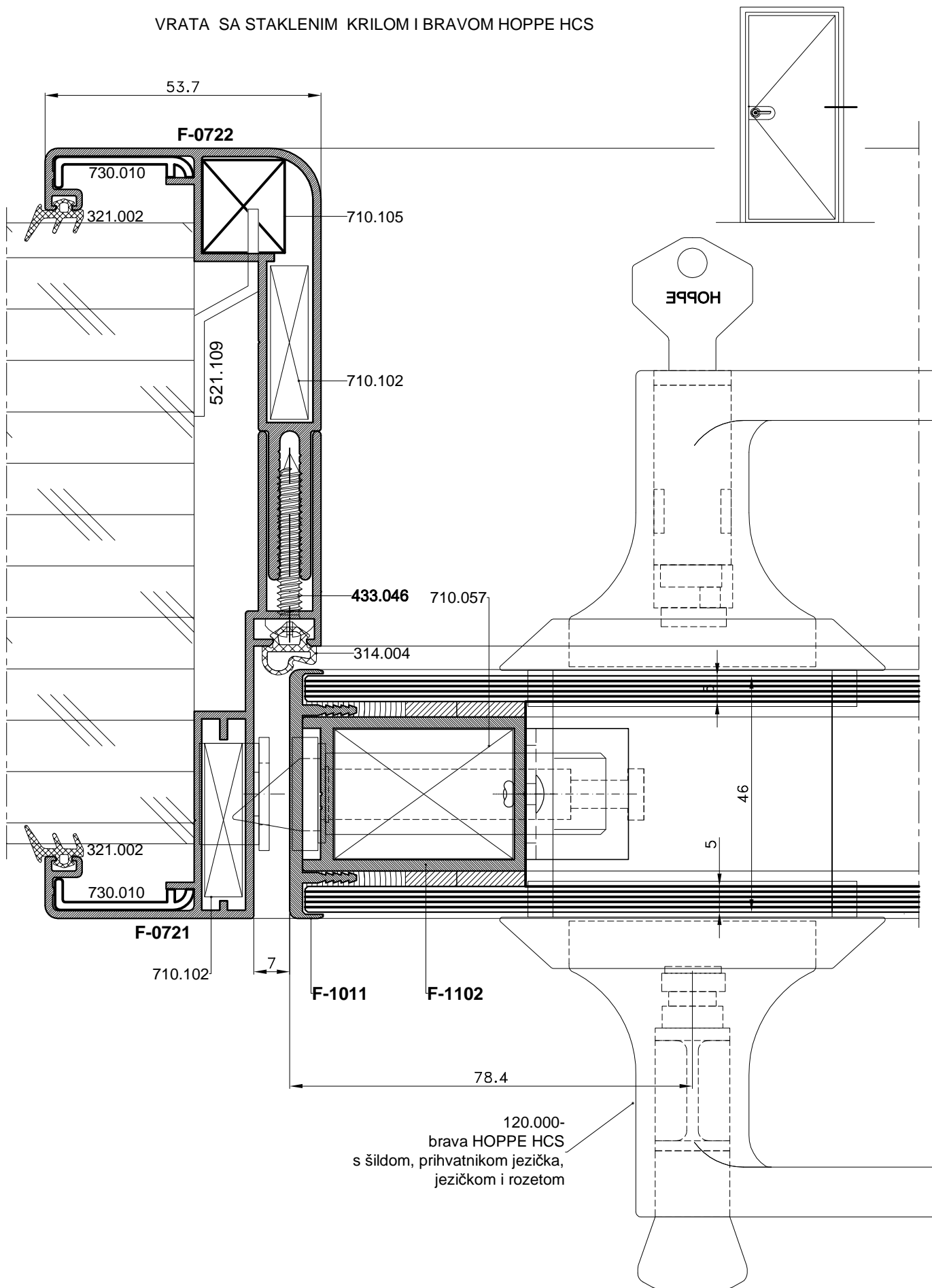

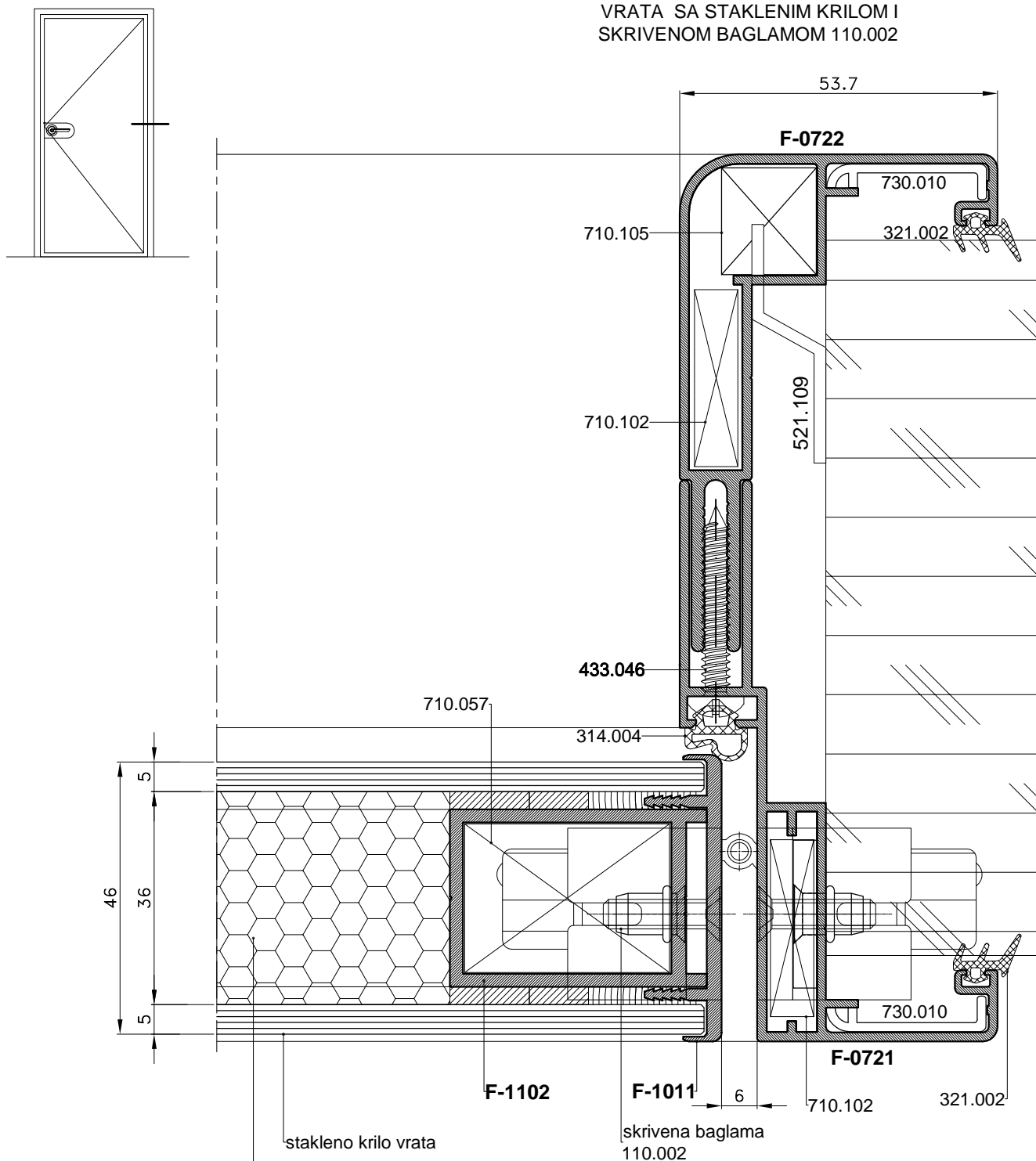
VRATA SA STAKLENIM KRILOM I
 SKRIVENOM BAGLAMOM 110.002

Napomena:

 U krilu, prostor između stakla može se ispuniti termo izolacijom (stiropor)
 uz korištenje neprozirnog (emajliranog) stakla

DVOKRILNA VRATA SA STAKLENIM KRILOM, BRAVOM HOPPE HCS I
SKRIVENOM ŠARKOM

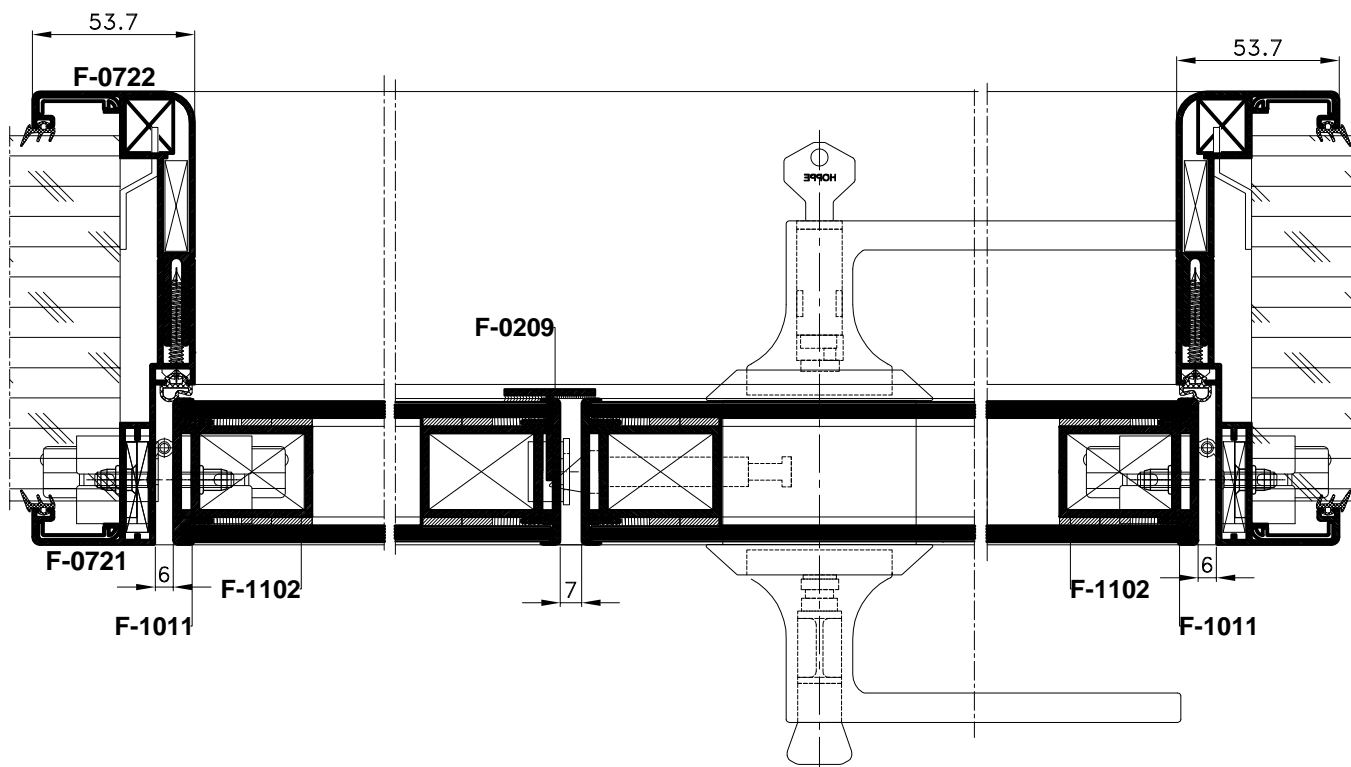
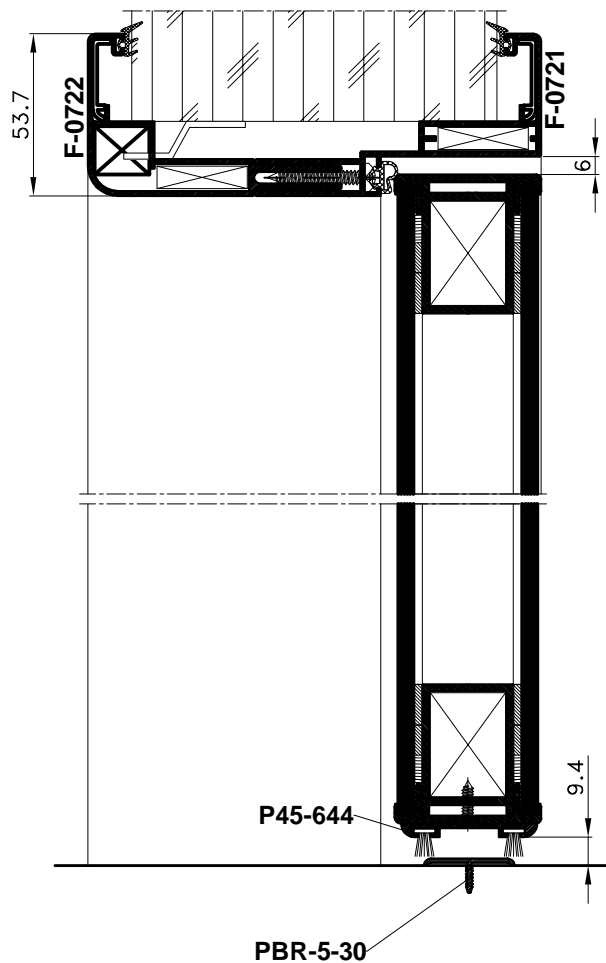
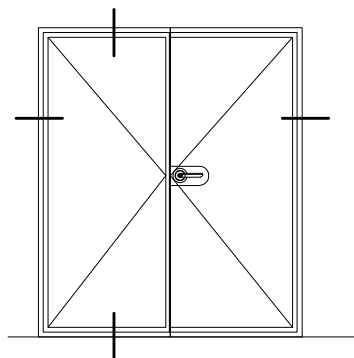

DVOKRILNA VRATA SA STAKLENIM KRILOM, BRAVOM HOPPE HCS I
SKRIVENOM ŠARKOM

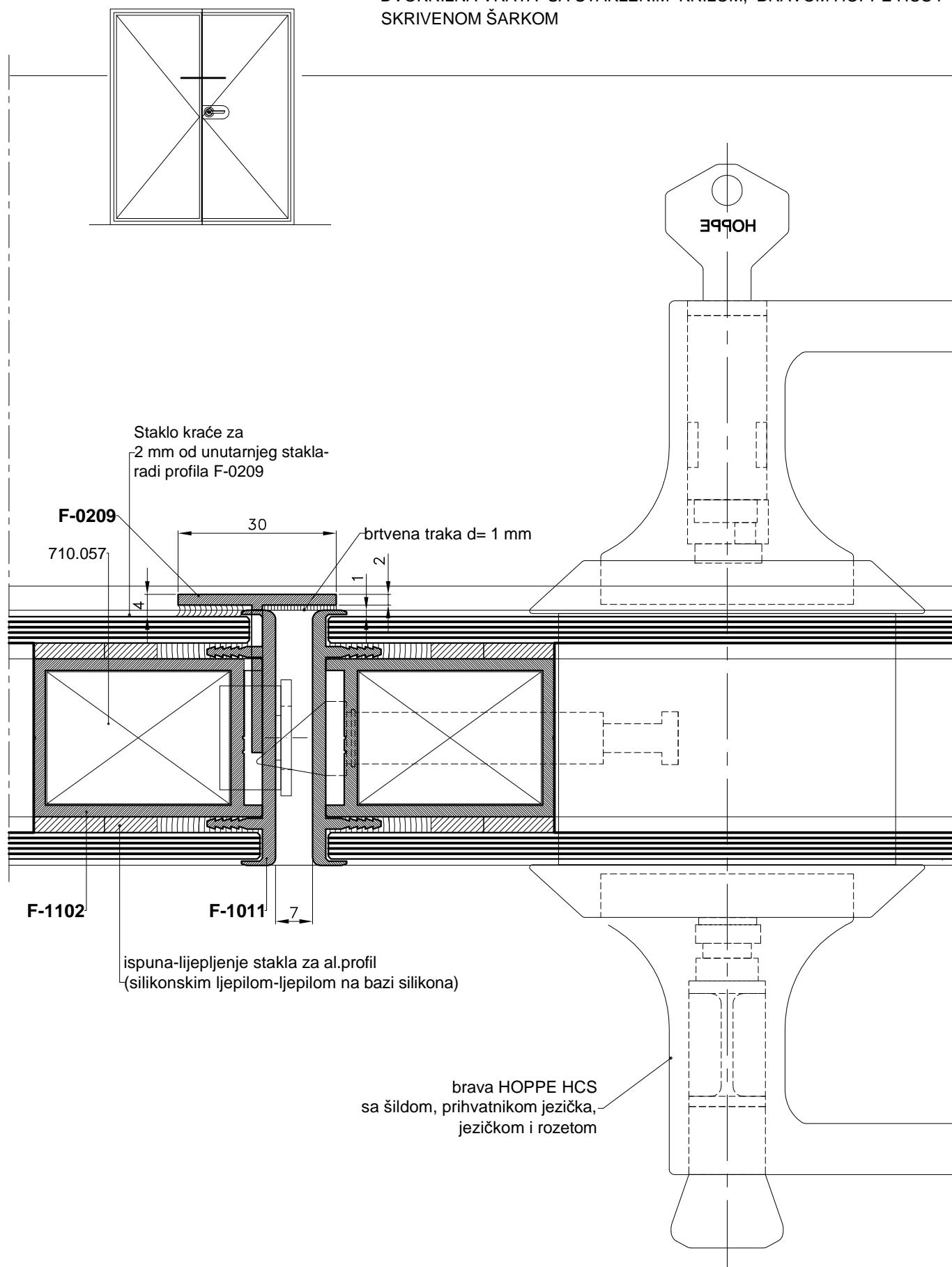

VRATA S DRVENIM KRILOM, BRAVOM HOPPE HCS I SKRIVENOM ŠARKOM

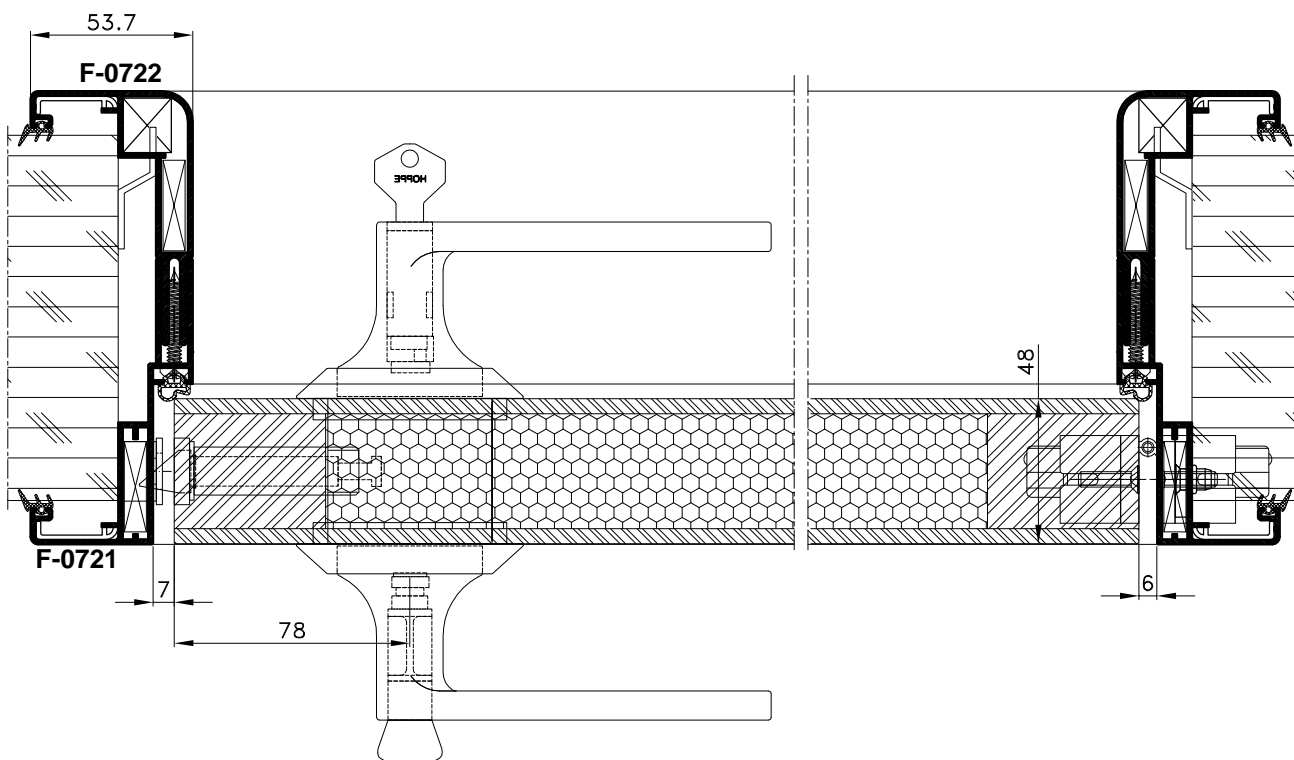
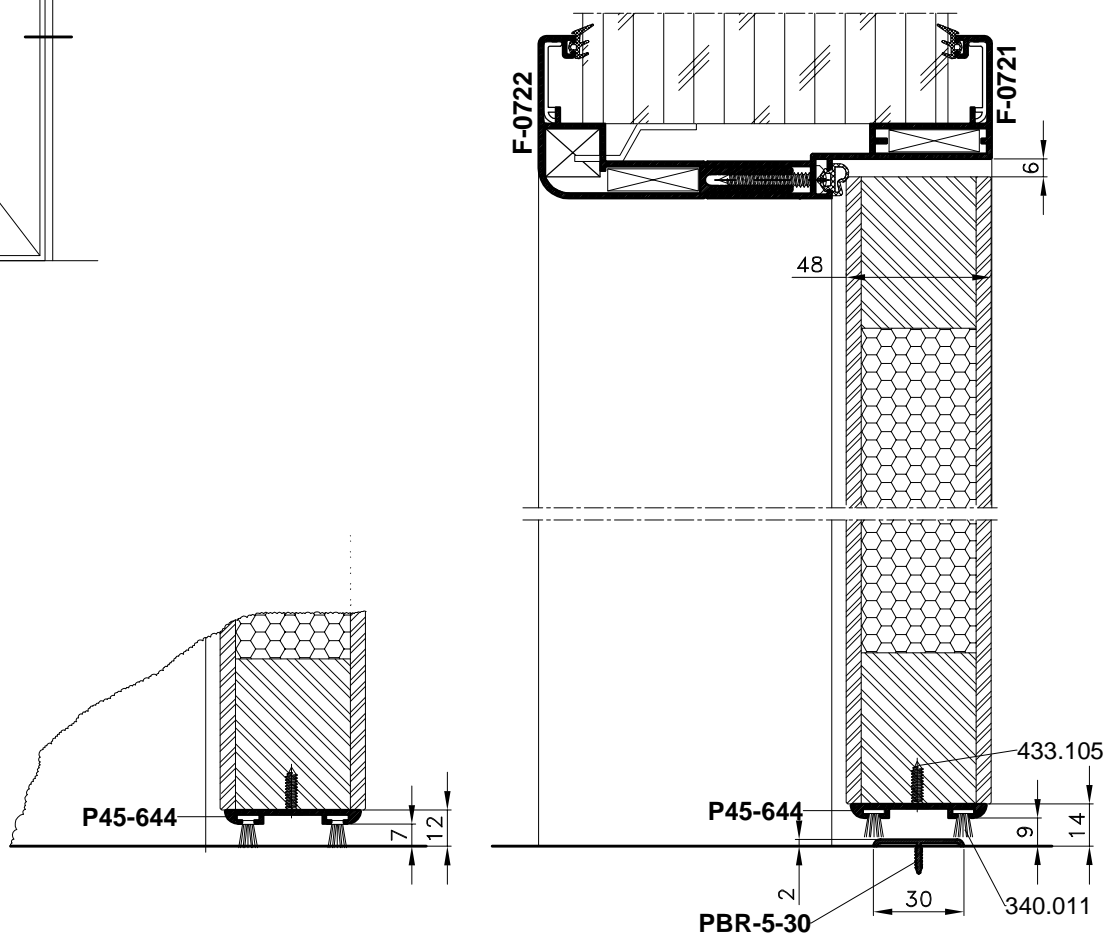
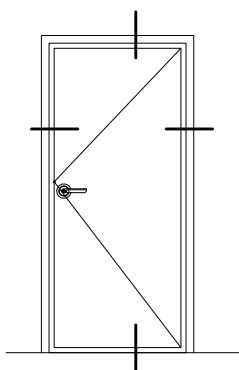

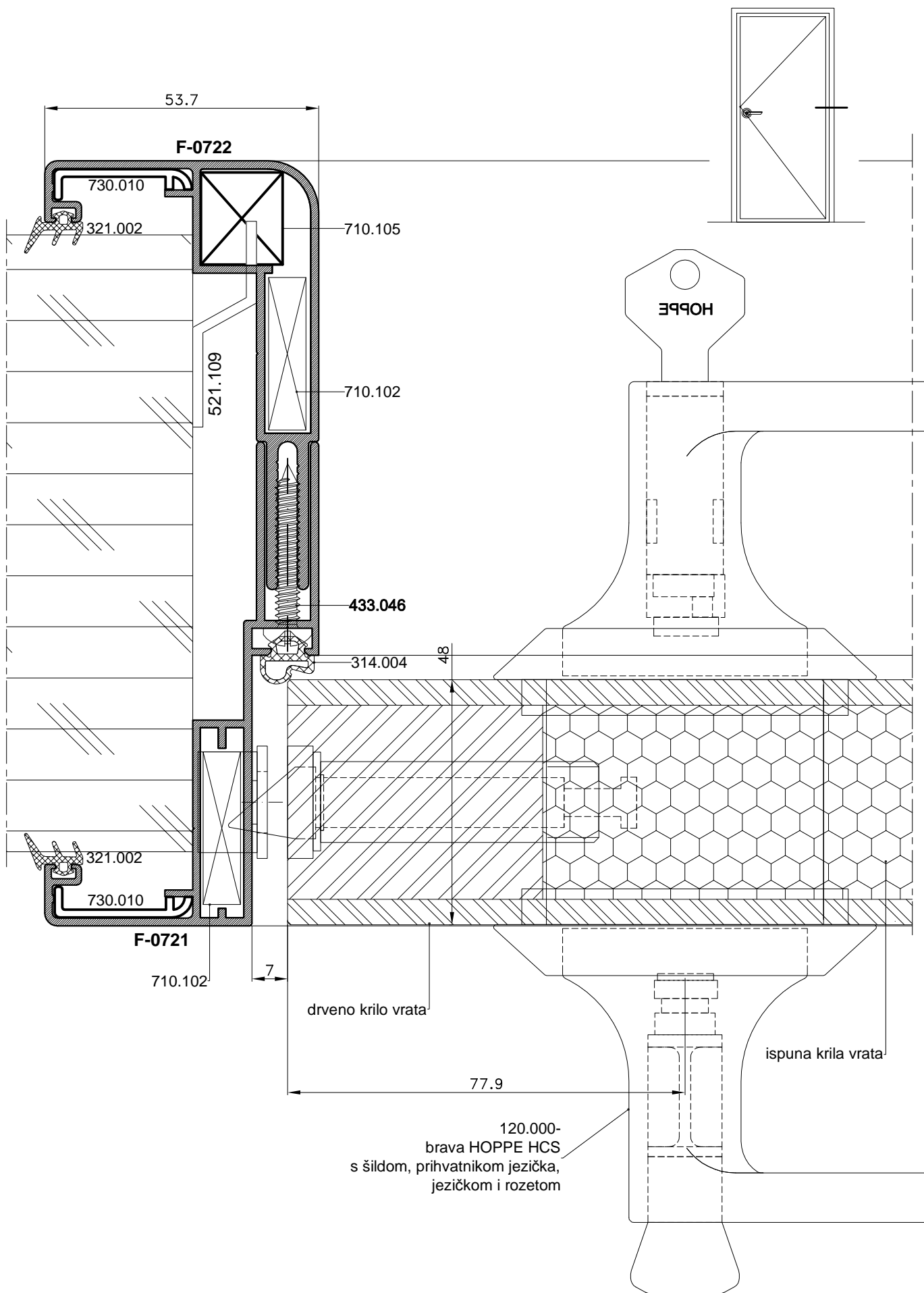

VRATIM S DRVENIM KRILOM I
SKRIVENOM BAGLAMOM 110.002

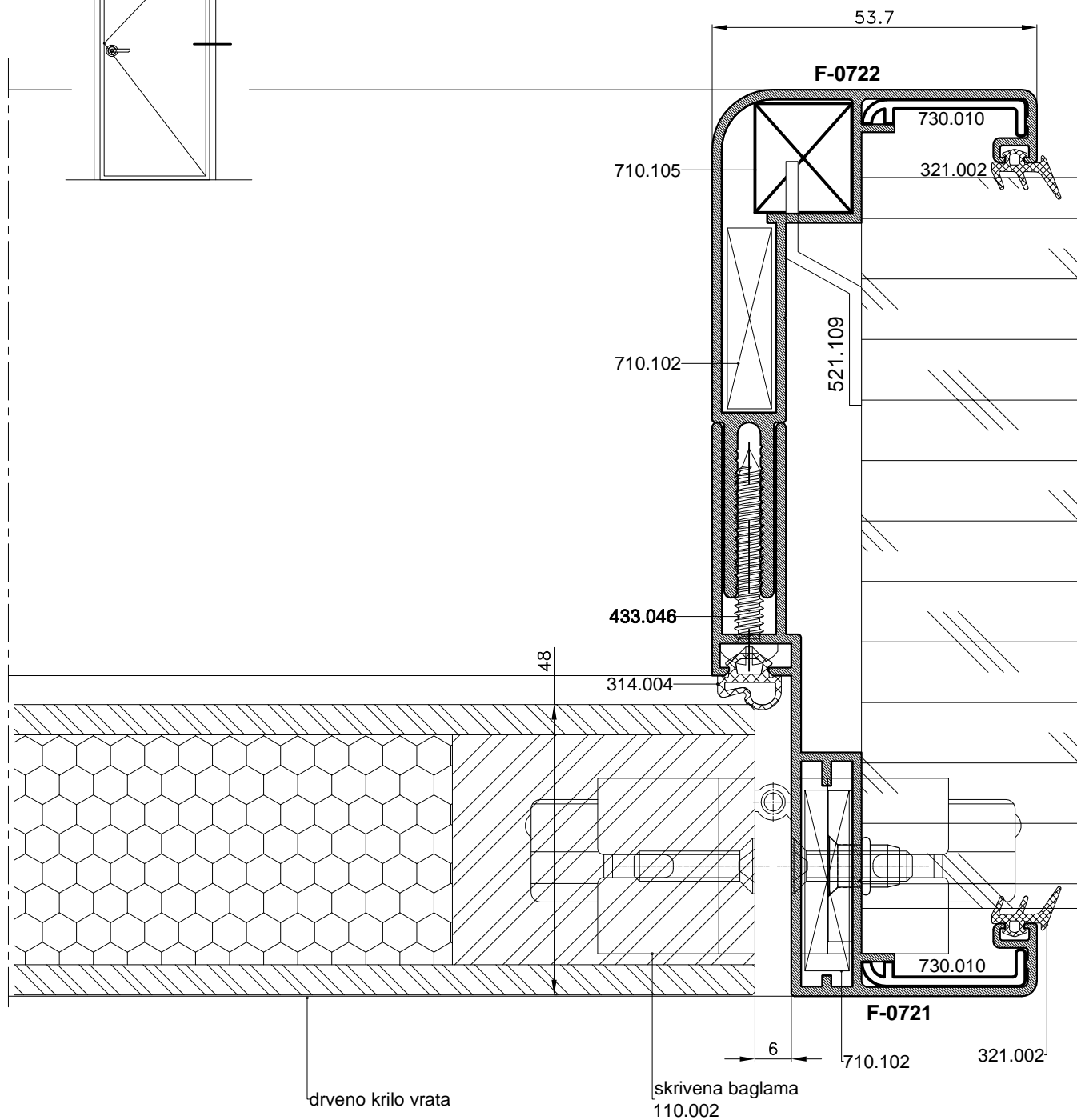

DVOKRILNA VRATA SA DRVENIM KRILOM, BRAVOM HOPPE HCS I
SKRIVENOM ŠARKOM

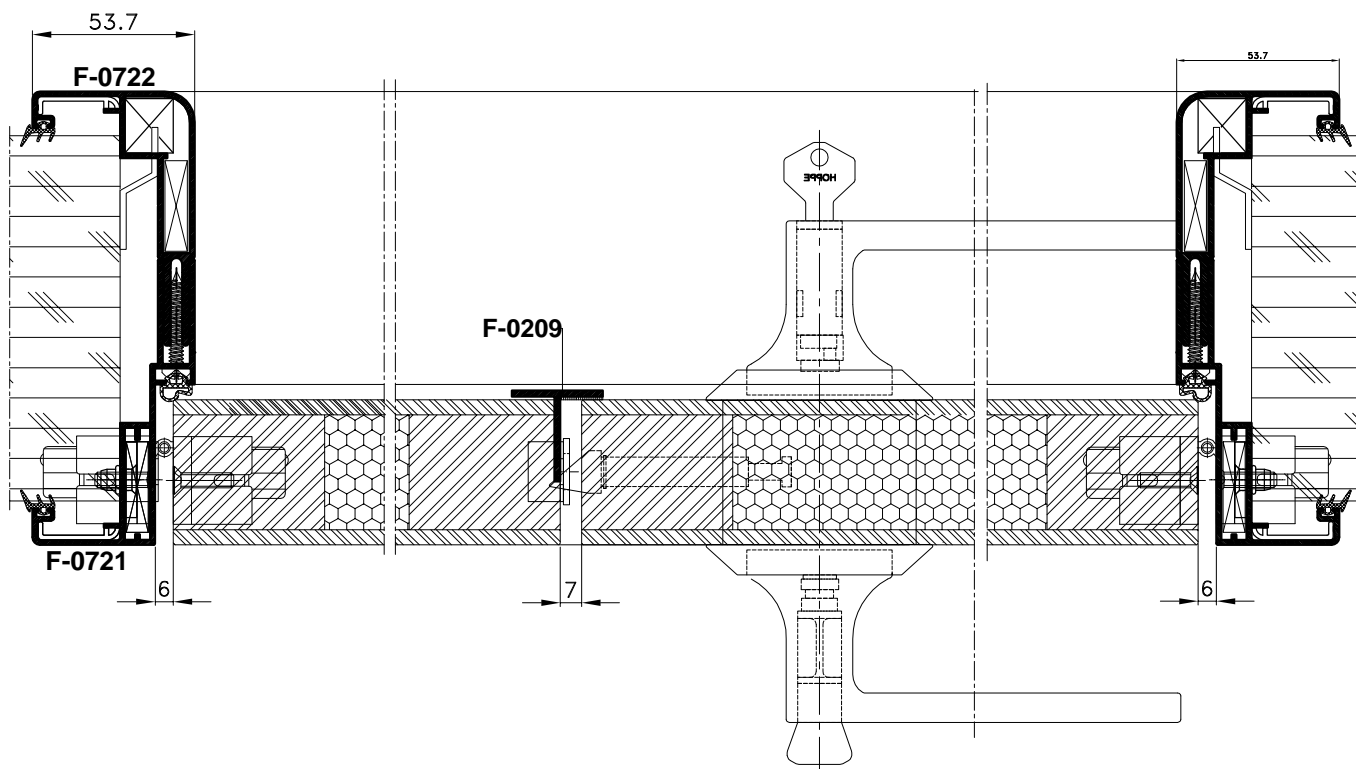
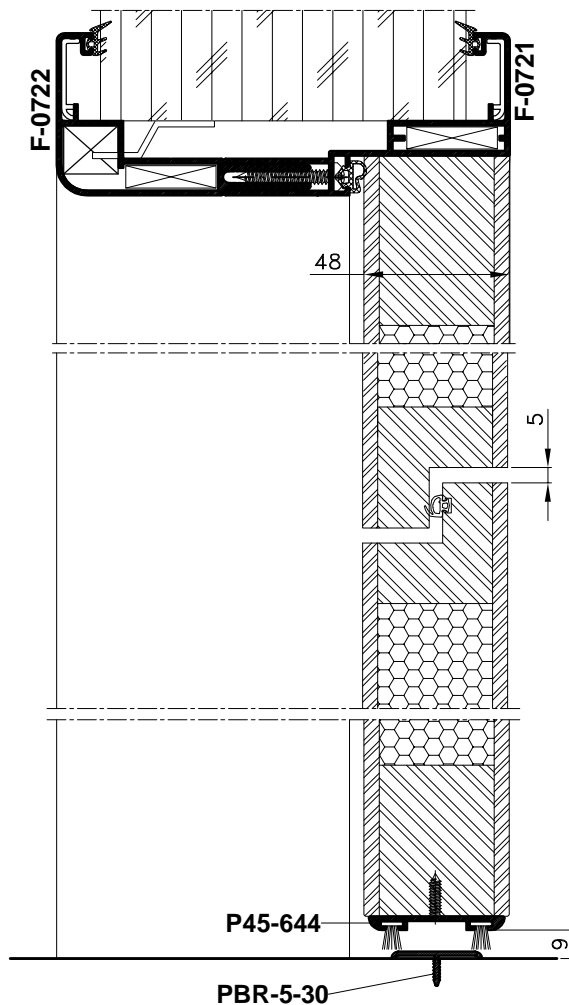
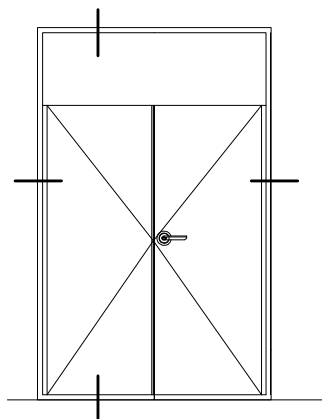

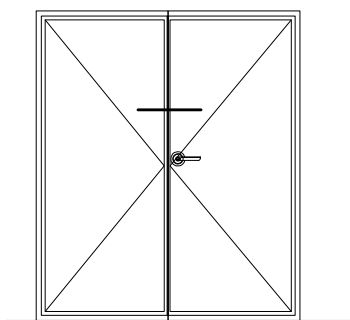

DVOKRILNA VRATA SA DRVENIM KRILOM, BRAVOM HOPPE HCS I
SKRIVENOM ŠARKOM

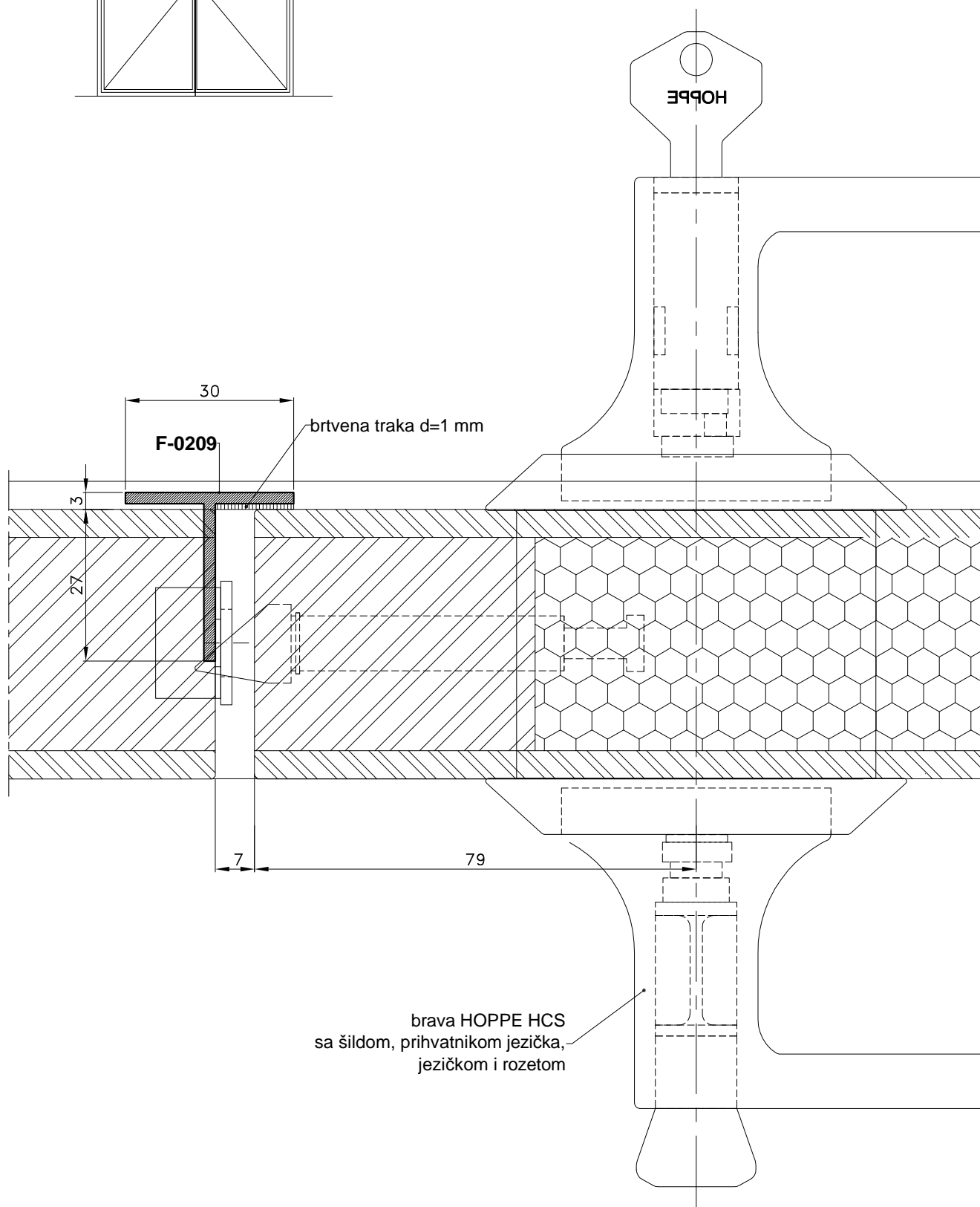

DETALJI OBRADÉ I MONTAŽE

OBRADA PROFILA DOVRATNIKA ZA PRIHVAT BAGLAME 111.012.xx
 -ZA DRVENO KRILO VRATA

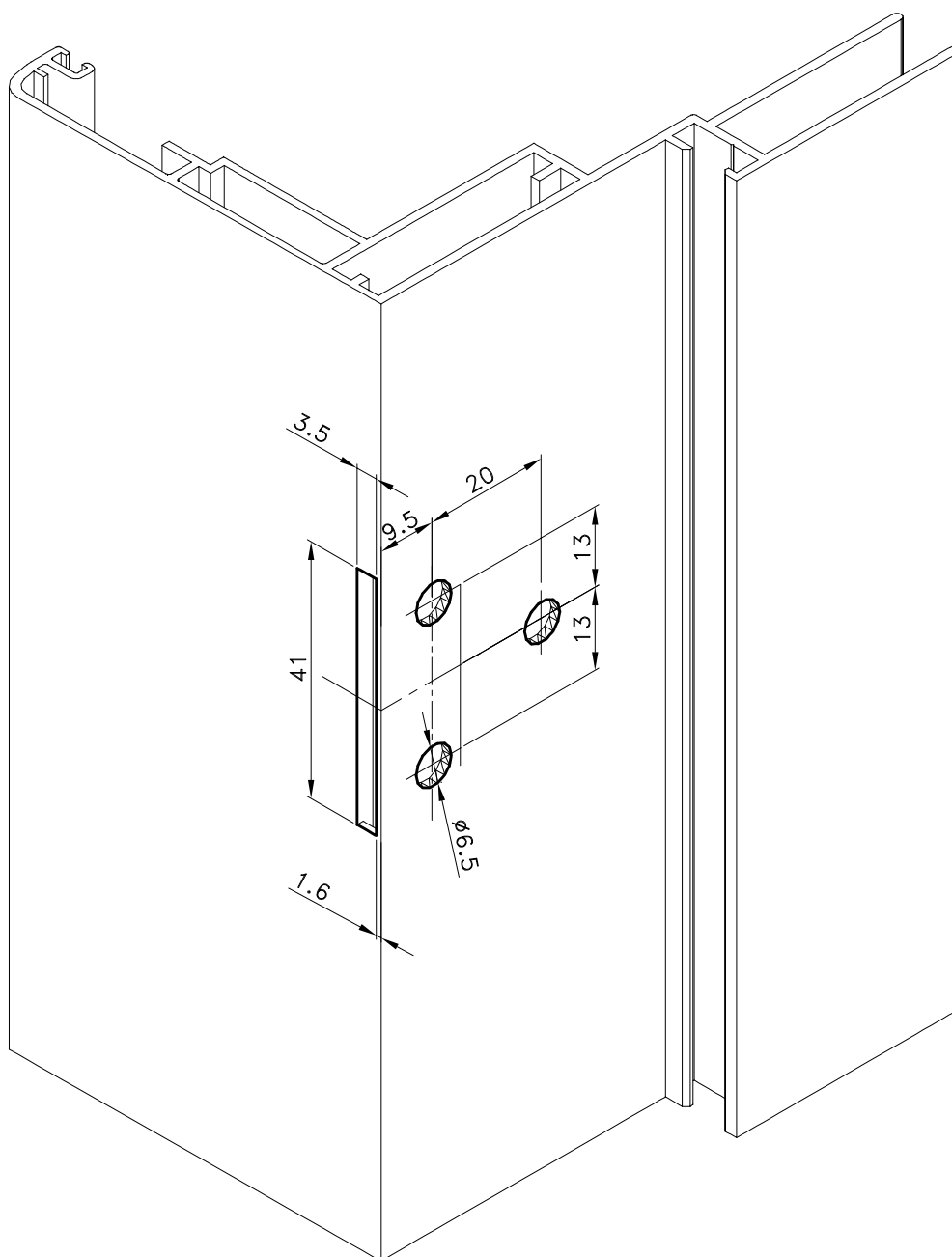

OBRADA JE ISTA ZA SVE NAVEDENE PROFILE:

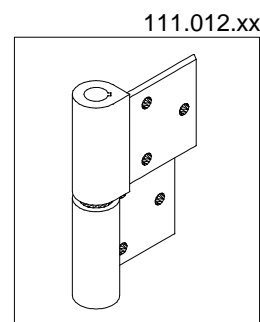
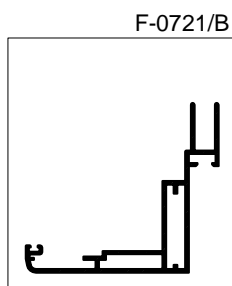
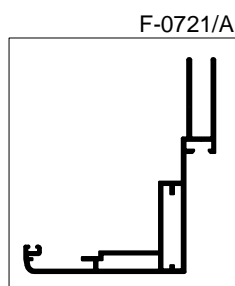
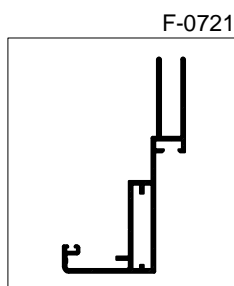

UGRADNJA DIJELA BAGLAME 111.012.xx NA PROFIL DOVRATNIKA

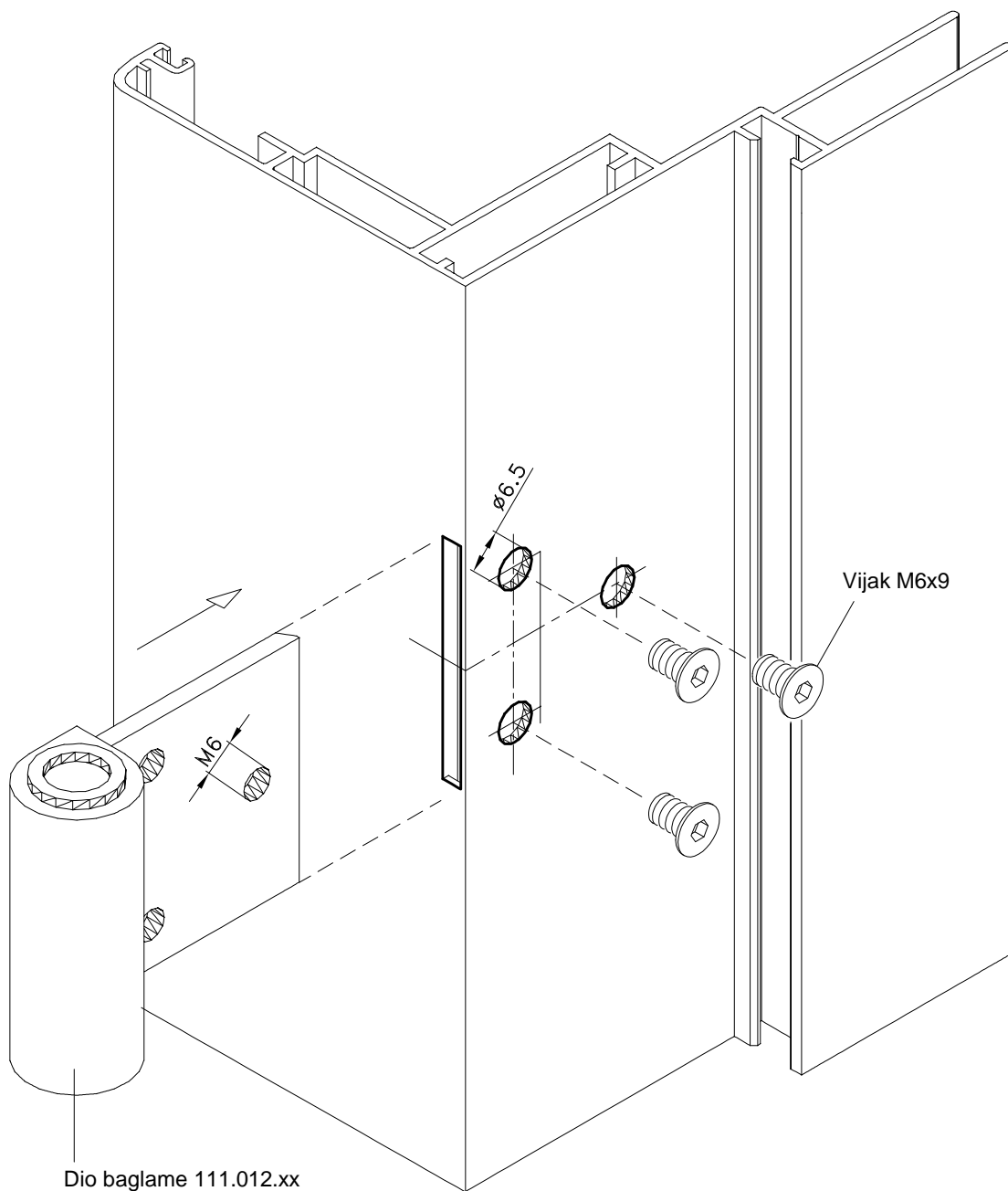

VRIJEDI ZA SVE NAVEDENE PROFILE:

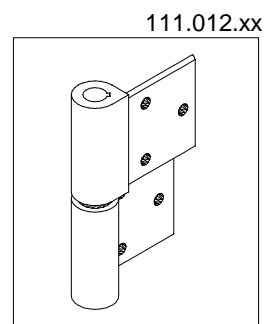
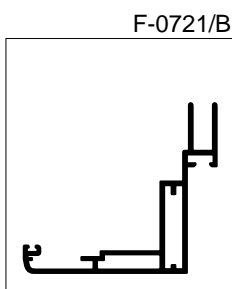
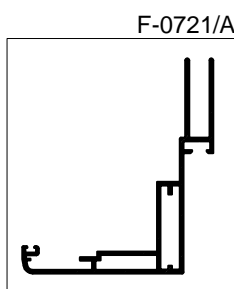
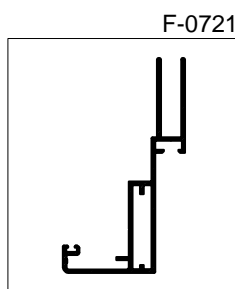

OBRADA I UGRADNJA DIJELA BAGLAME 111.012.xx NA KRILO
 DRVENIH VRATA d=48 MM

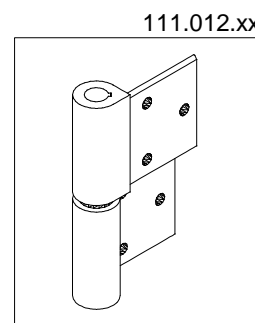
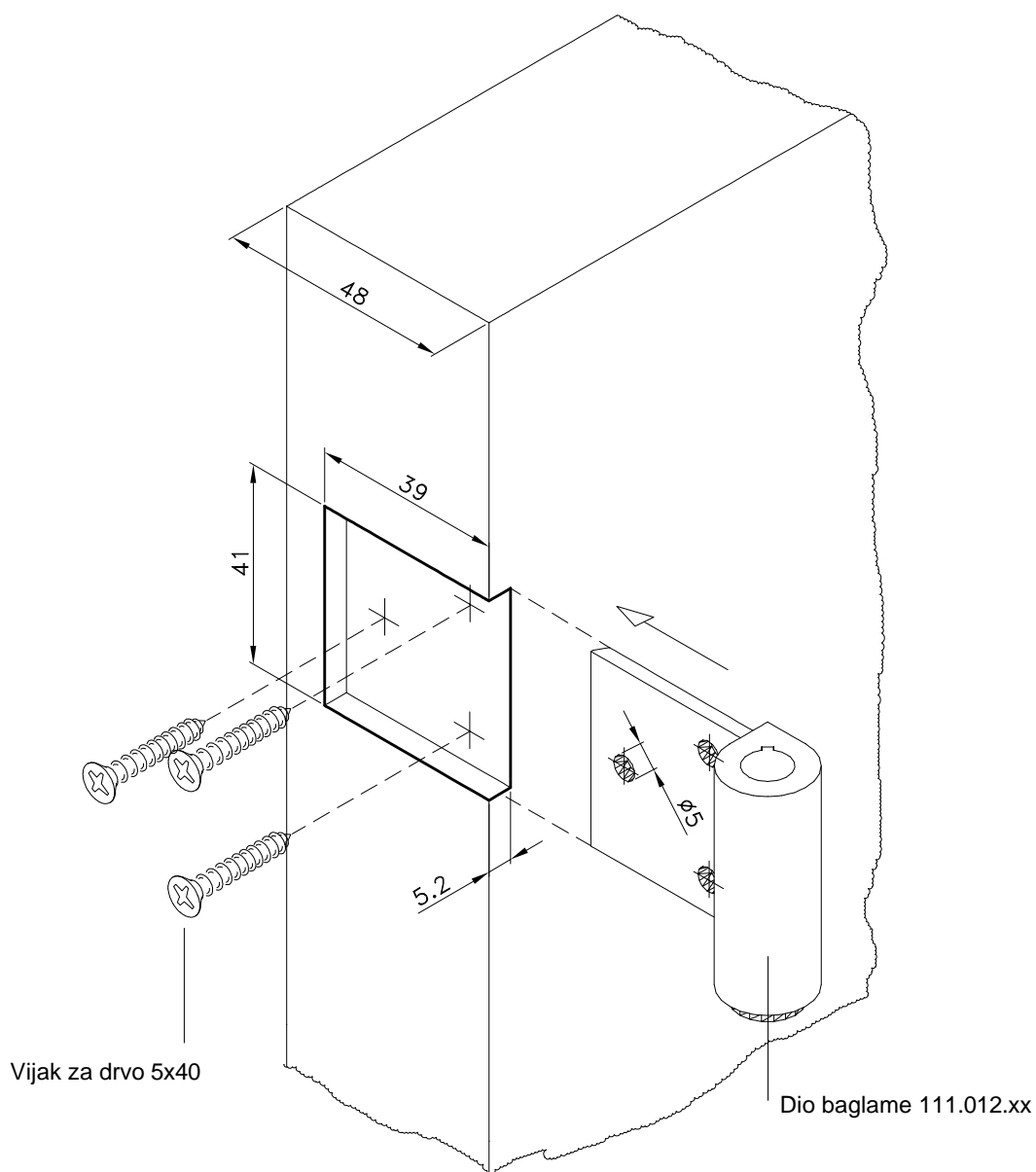

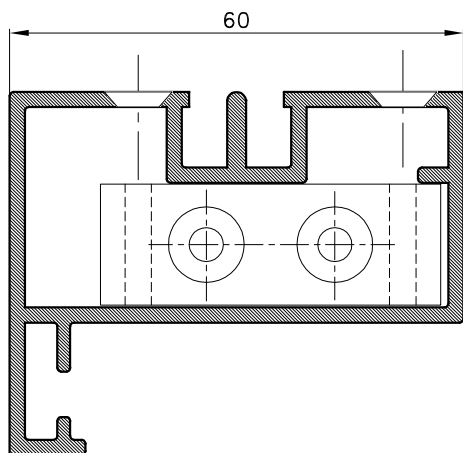

OBRADA PROFILA PREČKE **060 536**
 PREMA PROFILU OBLOGE DOVRATNIKA
 F-0721, F-0721-A, F-0721-B
 -ZA KUTNIK 370.014

060 536

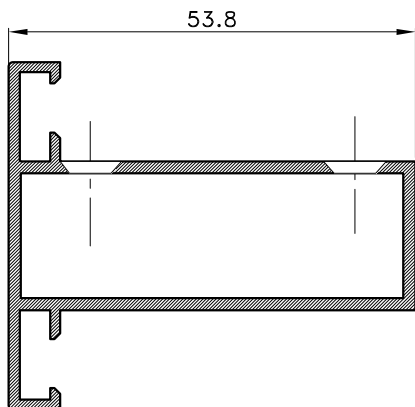
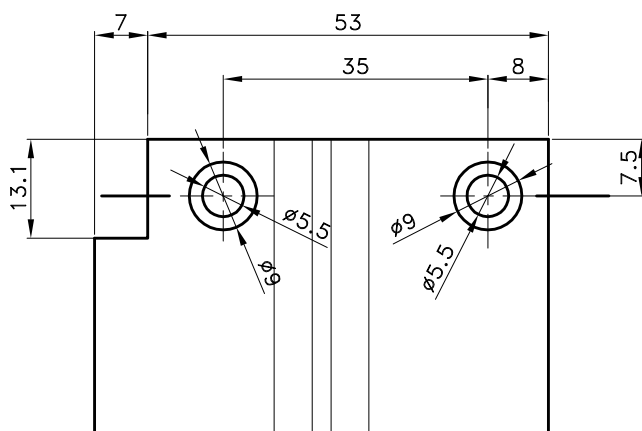

OBRADA PROFILA PREČKE **F-1009**
 PREMA PROFILU OBLOGE DOVRATNIKA
 F-0721, F-0721-A, F-0721-B
 -ZA KUTNIK 370.014

F-1009

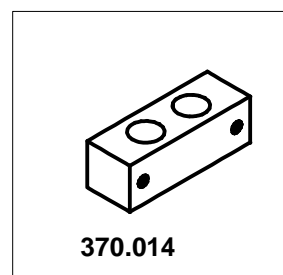
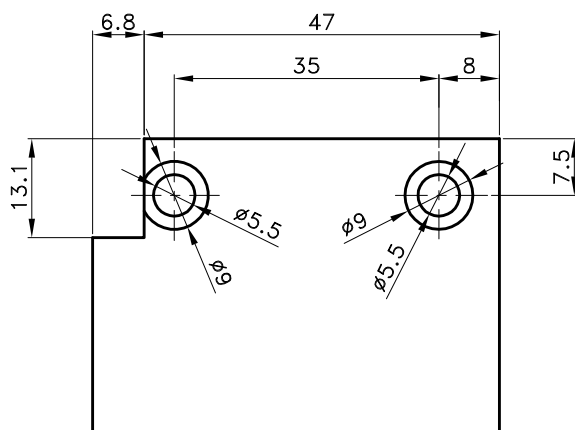

370.014

-OBRADA NA PROFILU DOVRATNIKA ZA PRIHVAT VEZNIKA 370.014

-UGRADNJA PREČKE 060536 NA DOVRATNIK VEZNIKOM 370.014

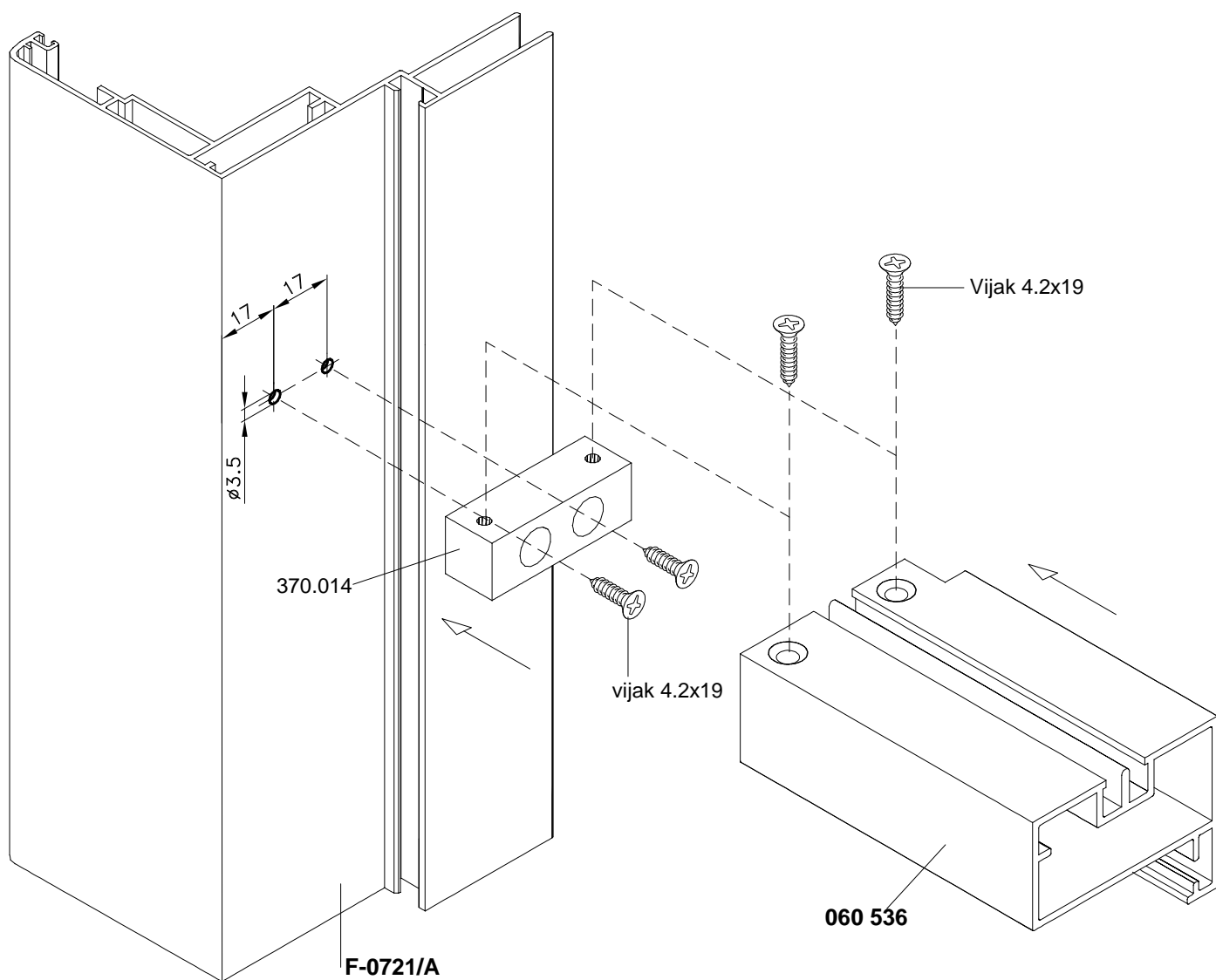

OBRADA I UGRADNJA

OBRADA PROFILA DOVRATNIKA ZA PLOČICU ZA UGRADNJU 521.110

- Pločica za ugradnju 521.110 koristi se za bolje vođenje profila obloge u osi x kao i za držanje razmaka okvira od zida po osi y.
- Ugrađuje se mjestimično po visini
- Materijal pločice: aluminij

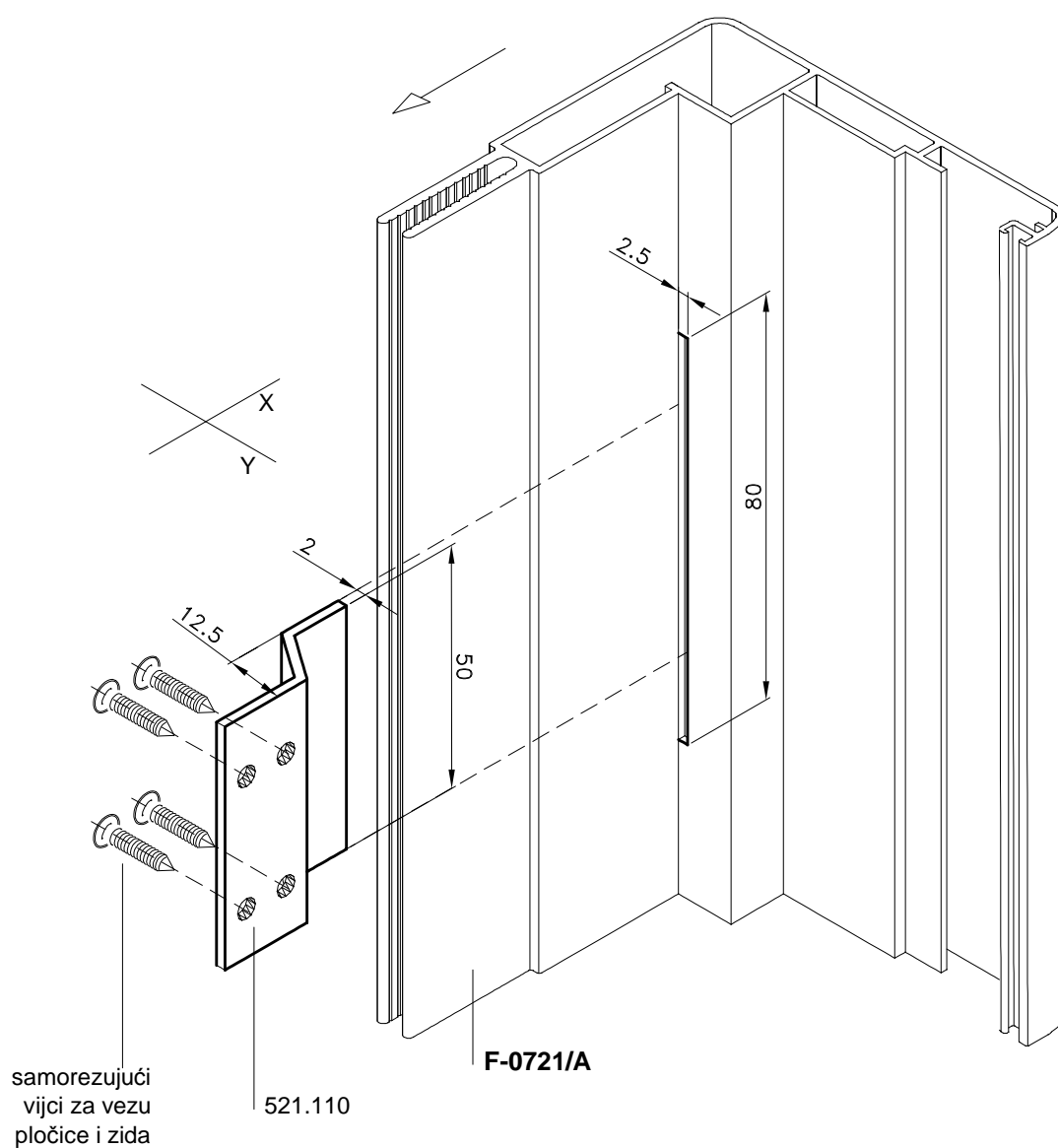

SPAJANJE PROFILA KUTNICIMA POD 90°

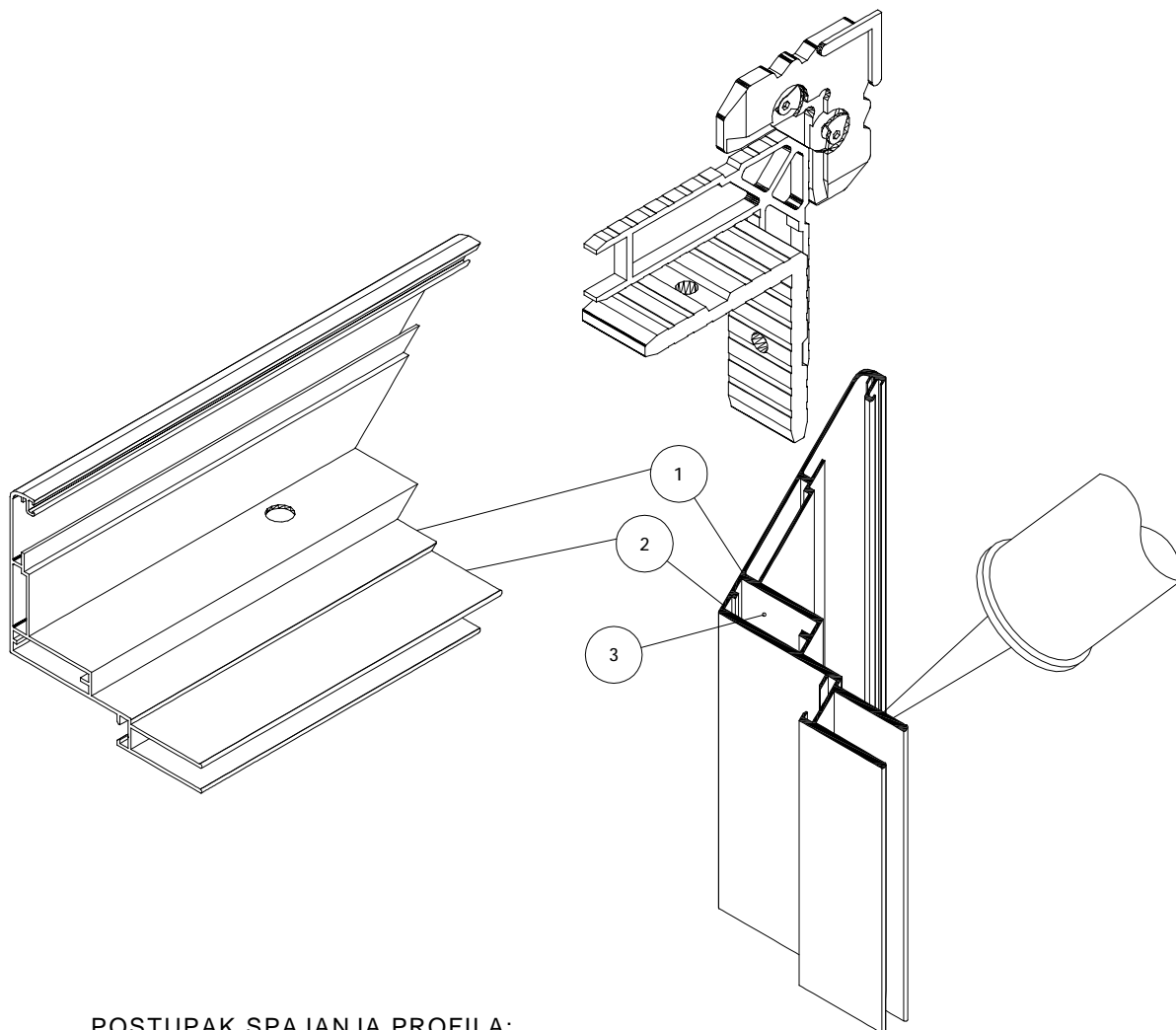

POSTUPAK SPAJANJA PROFILA:

1. Površine koje se spajaju-rezove očistiti i odmastiti prikladnim sredstvom /npr. Sika Remover 208; Wurth-kat.br.:892 130 30/.
2. Premazati površine koje se spajaju ljepilom za metal /npr. Sika Force 7851; Wurth-kat.br.:892 130 010/.
3. Ljepilo za metal ušpricati u komoru za kutnik - po opsegu komore
4. Profile s kutnikom izravnati i spojiti
5. Dio ljepila koji iscure između rezova očistiti sredstvom za čišćenje i odmašćivanje /npr. Sika Remover 208; Wurth-kat.br.:892 130 30/.

NAPOMENA:

Ovaj postupak spajanja profila primjenjiv je za sve Feal-ove kutnike i njima odgovarajuće komore:

Lijepljenjem rezova i kutnika ljepilima za metal osigurava se potrebna zrako- i vodonepropusnosti spoja kao i dodatna mehanička čvrstoća spoja.

UGRADNJA DOVRATNIKA NA ZID

1. profile vanjske obloge 1 i unutarnje obloge 3 u radionici spojiti kutnicima te po potrebi na vanjsku oblogu 1 ugraditi (vijcima) profil proširivača F-0720 (obloga 2)
2. nakon dovođenja u položaj za ugradnju, prvo se na zid ugrađuje vanjska obloga 1 a zatim unutarnja obloga 3 koja se veže za oblogu 1 (ili za oblogu 2) vijcima 4.8x32

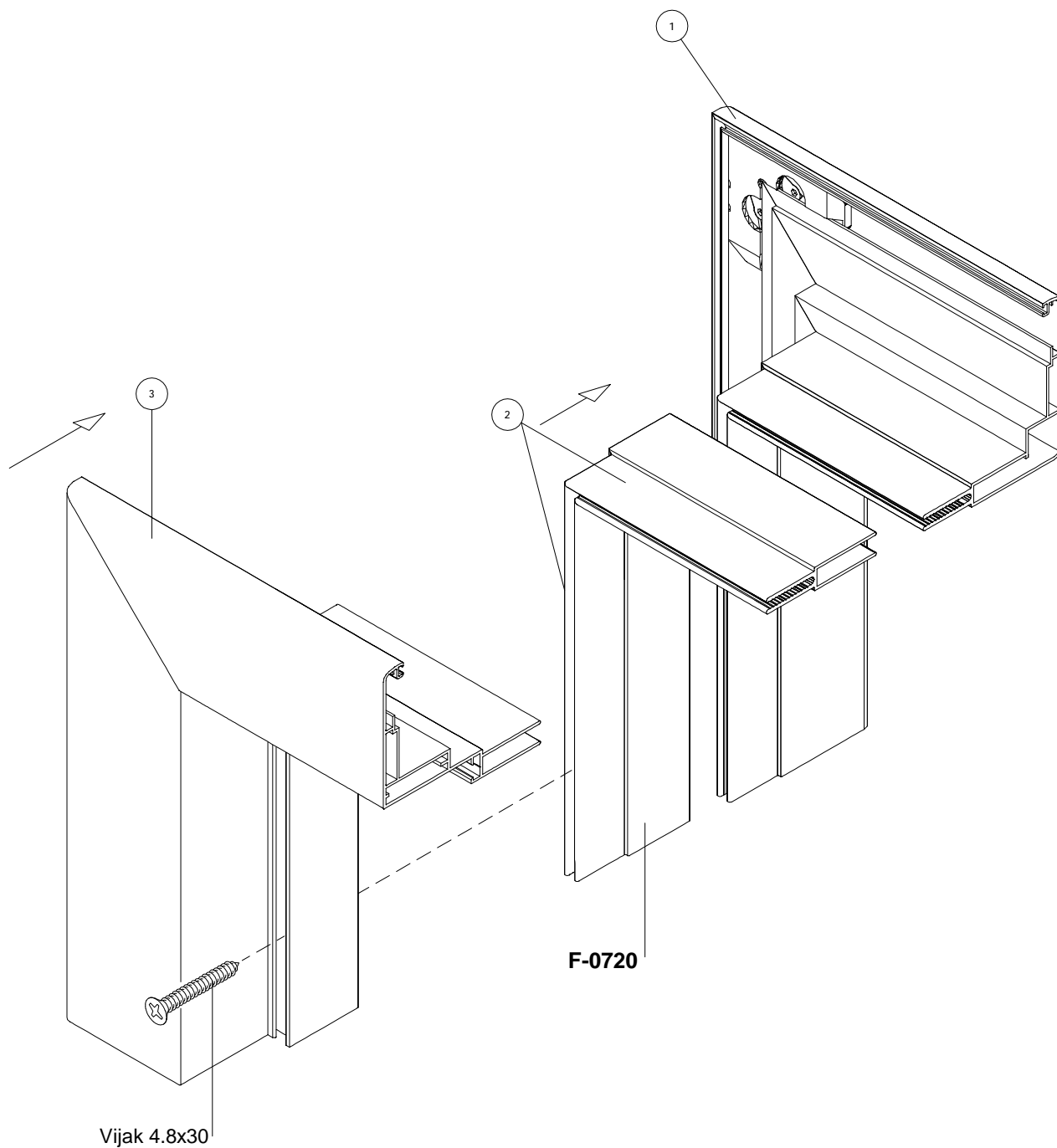

364.014-UMETAK ZA PROFIL Z50-654

- materijal:PVC
- gornji i donji umetak-simetrično
- mjera pilanja profila Z50-640: $H=Hkr-68$

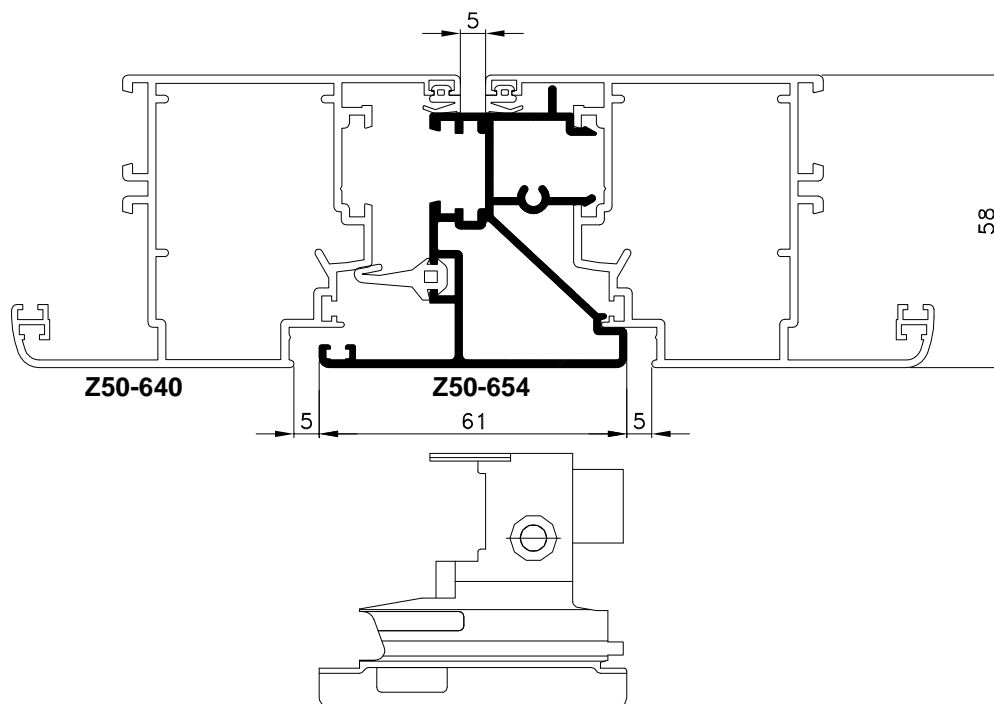
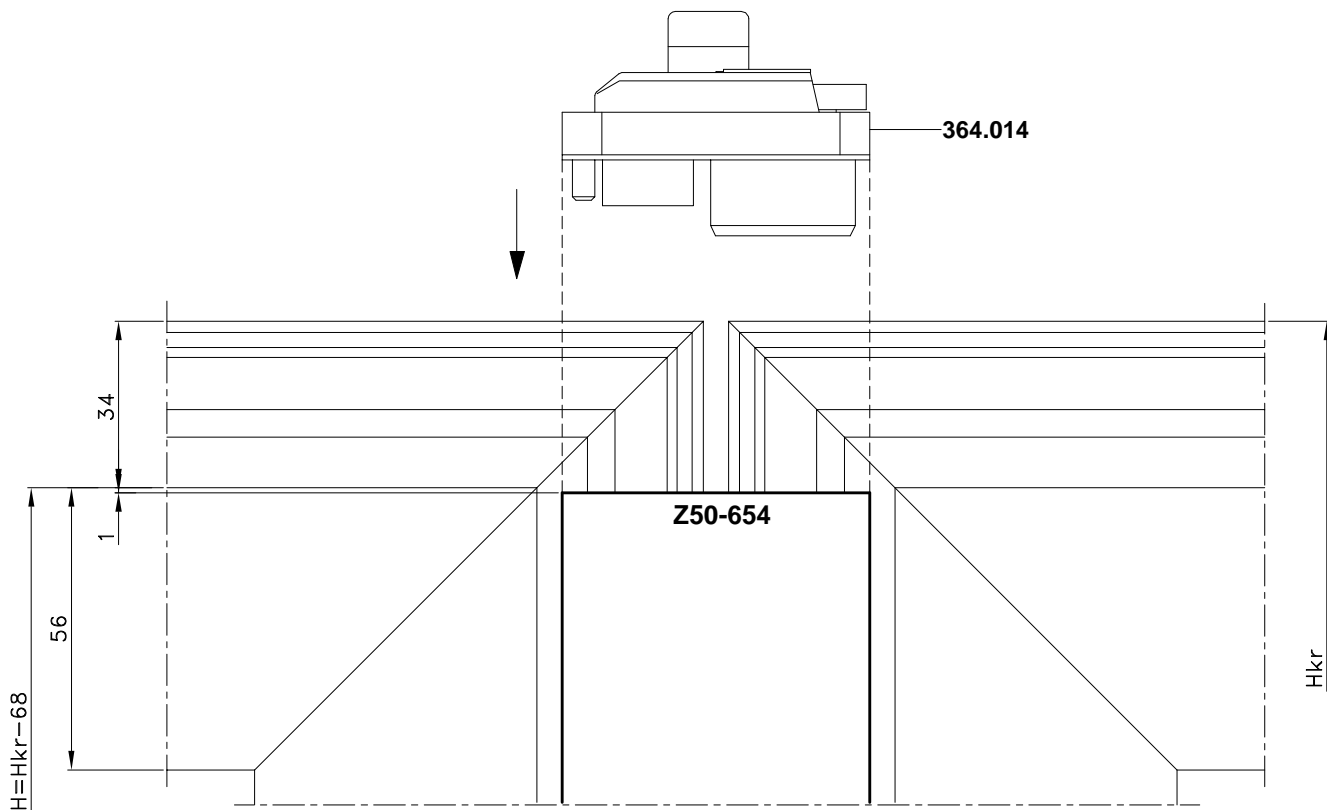

SPAJANJE PROFILA F-0721 KUTNICIMA

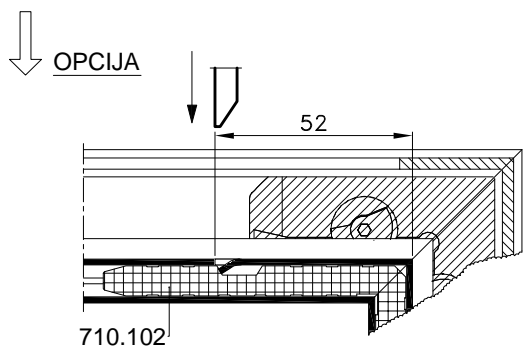
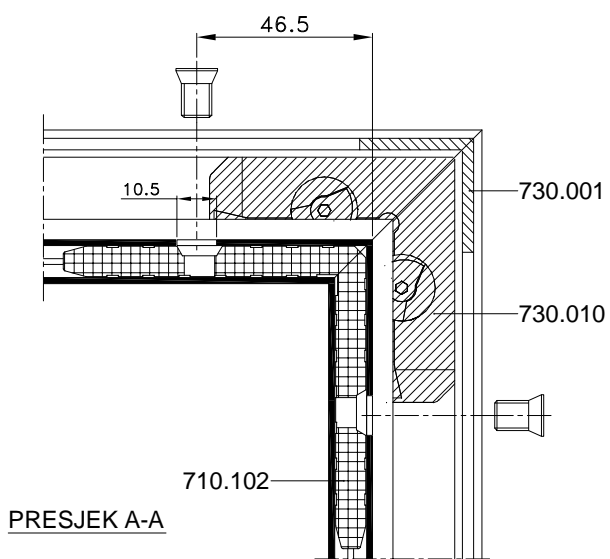
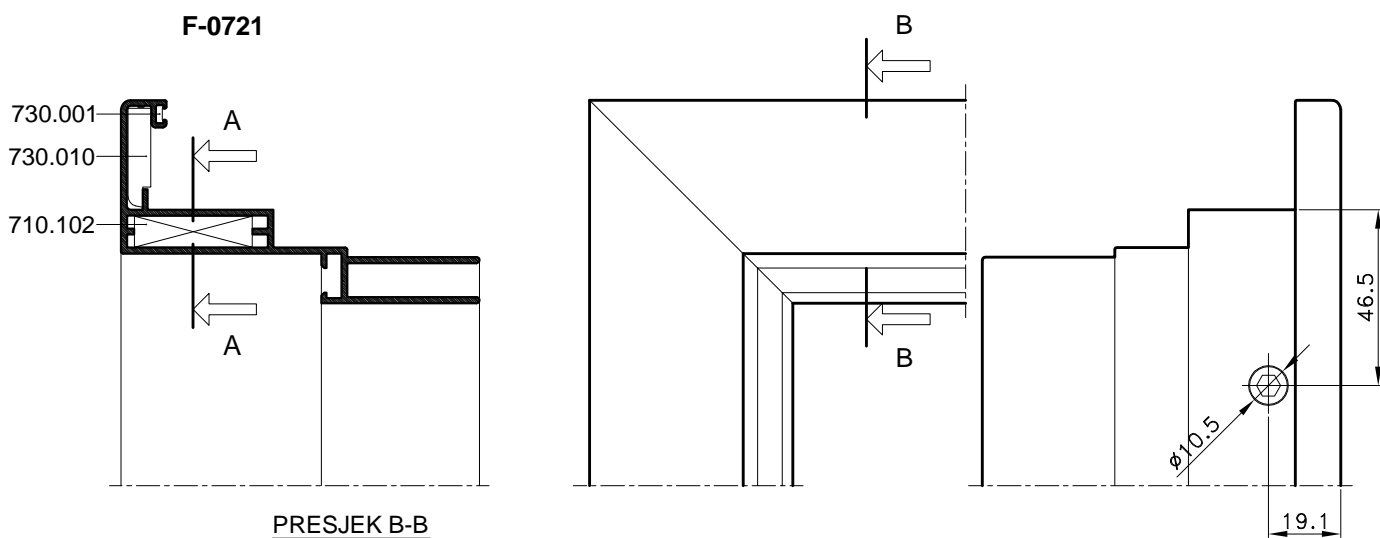

1. Spajanje kutnikom 710.102 - vijcima M8x13 -tip Feal
Opcija: spajanje kutnikom 710.102-uprešavanjem
2. Spajanje kutnikom 730.010 - zatezanje imbusom
3. Spajanje kutnikom 730.001

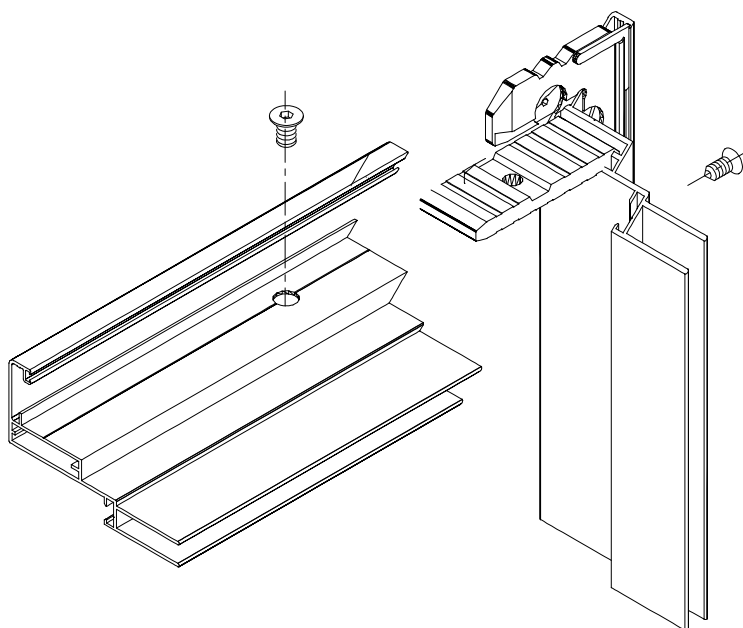

SPAJANJE PROFILA F-0721/A KUTNICIMA

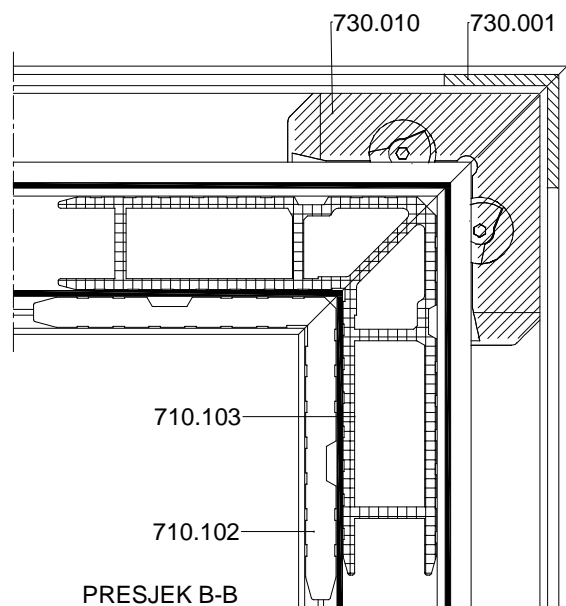
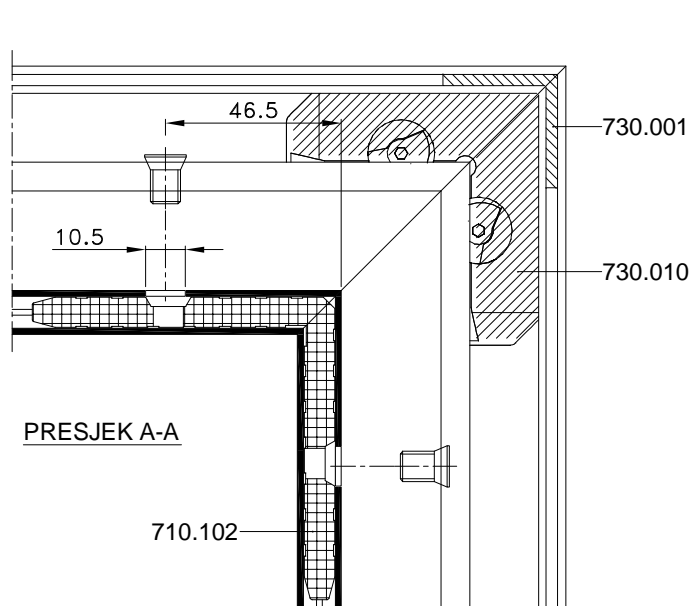
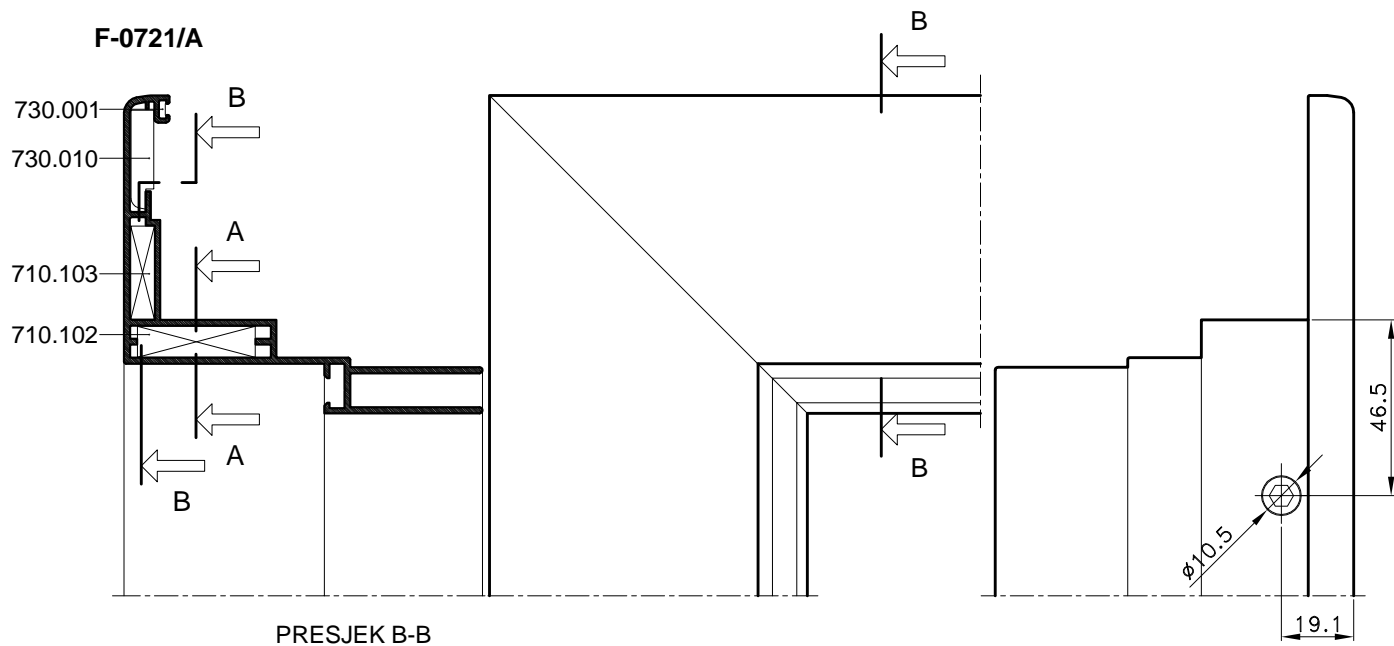

↓ OPCIJA

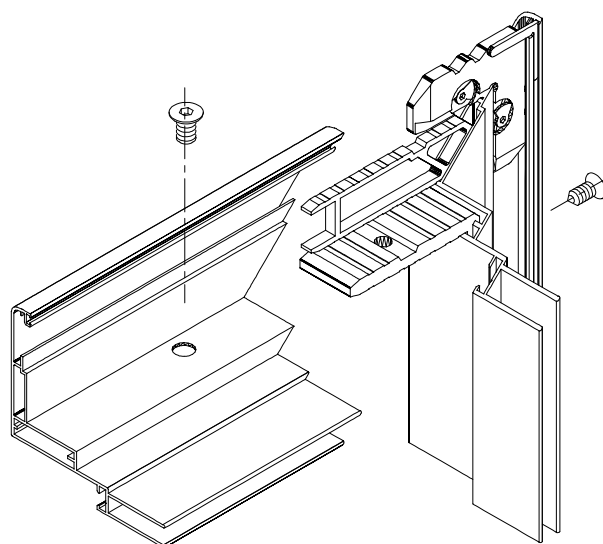
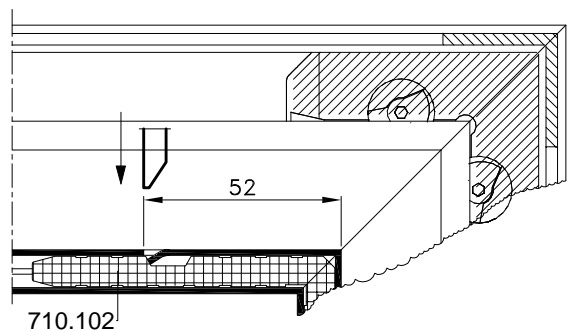

1. Spajanje kutnikom 710.102 - vijcima M8x13 -tip Feal
- Opcija: spajanje kutnikom 710.102-uprešavanjem
2. Spajanje kutnikom 710.103
3. Spajanje kutnikom 730.010 - zatezanje imbusom
4. Spajanje kutnikom 730.001

SPAJANJE PROFILA F-0721/B KUTNICIMA

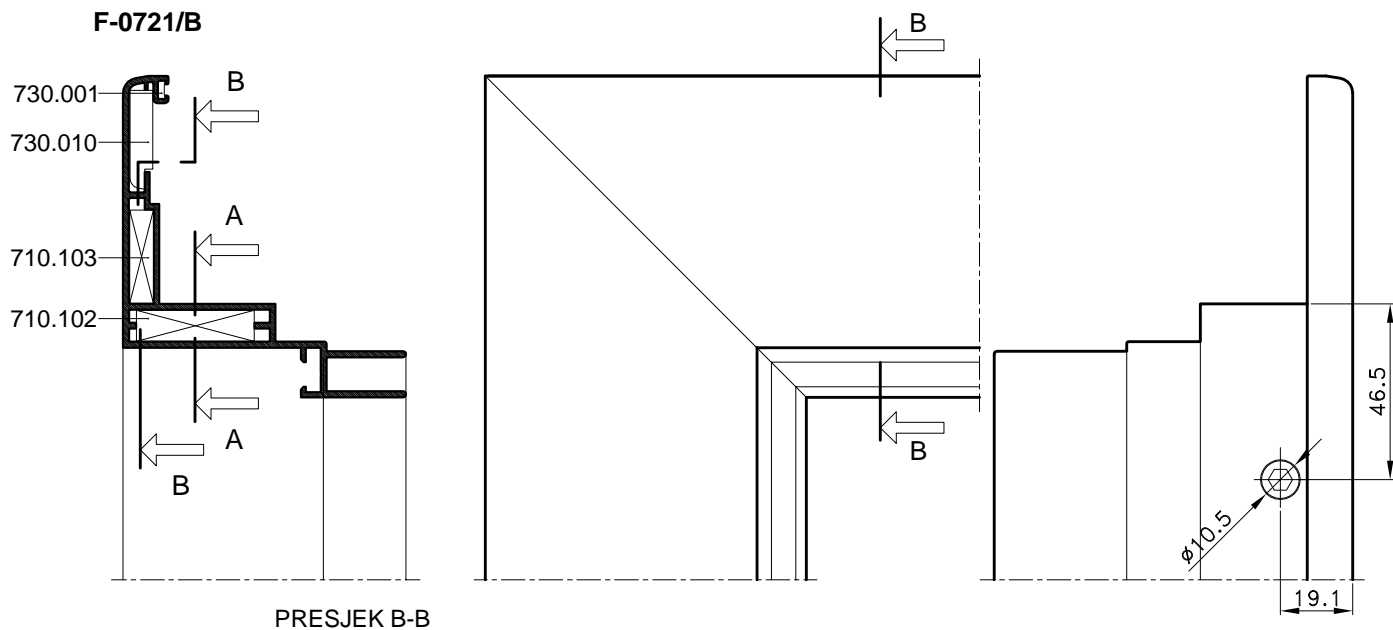

PRESJEK B-B

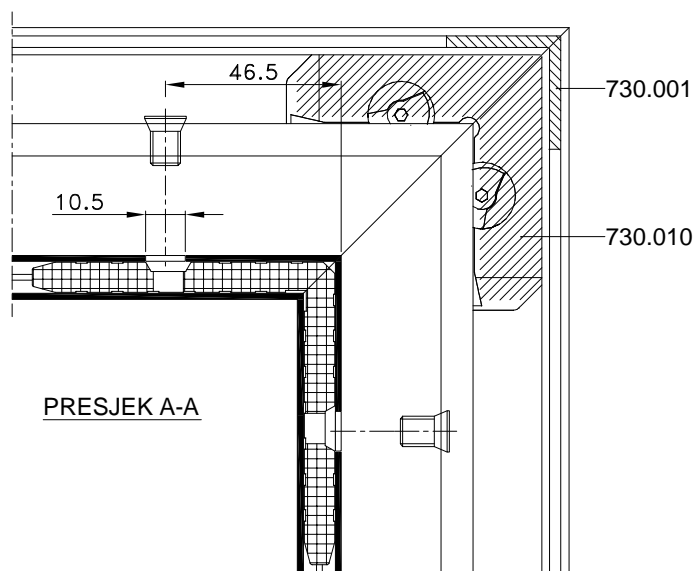

PRESJEK A-A

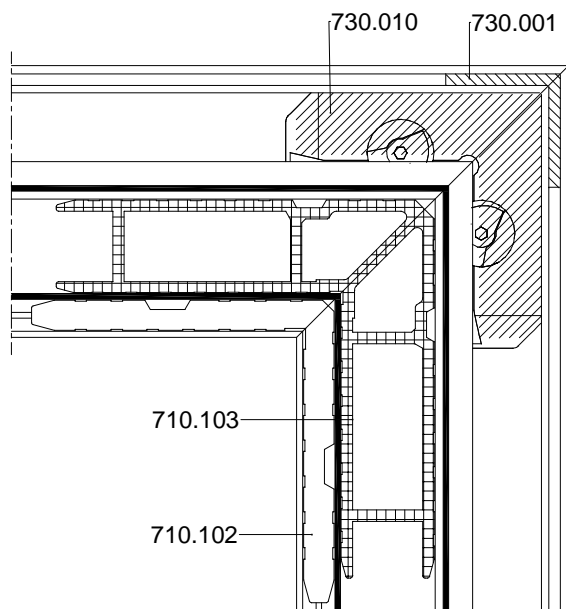

PRESJEK B-B

OPCIJA

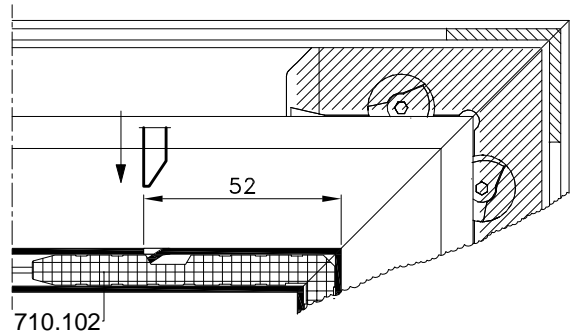

710.102

1. Spajanje kutnikom 710.102 - vijcima M8x13 - tip Feal
Opcija: spajanje kutnikom 710.102-uprešavanjem
2. Spajanje kutnikom 710.103
3. Spajanje kutnikom 730.010 - zatezanje imbusom
4. Spajanje kutnikom 730.001

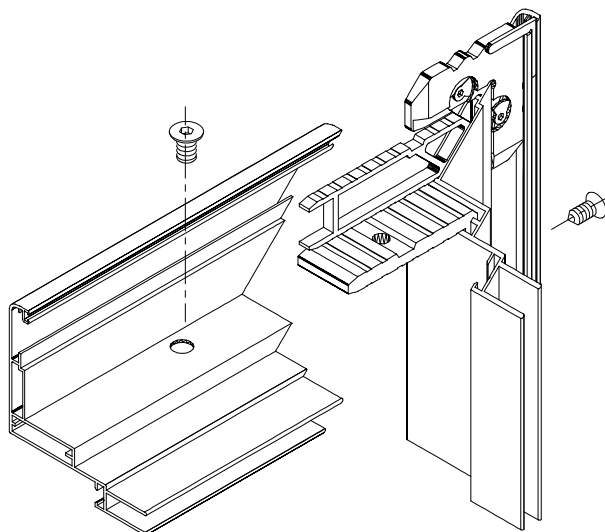

SPAJANJE PROFILA Z50-659 KUTNICIMA

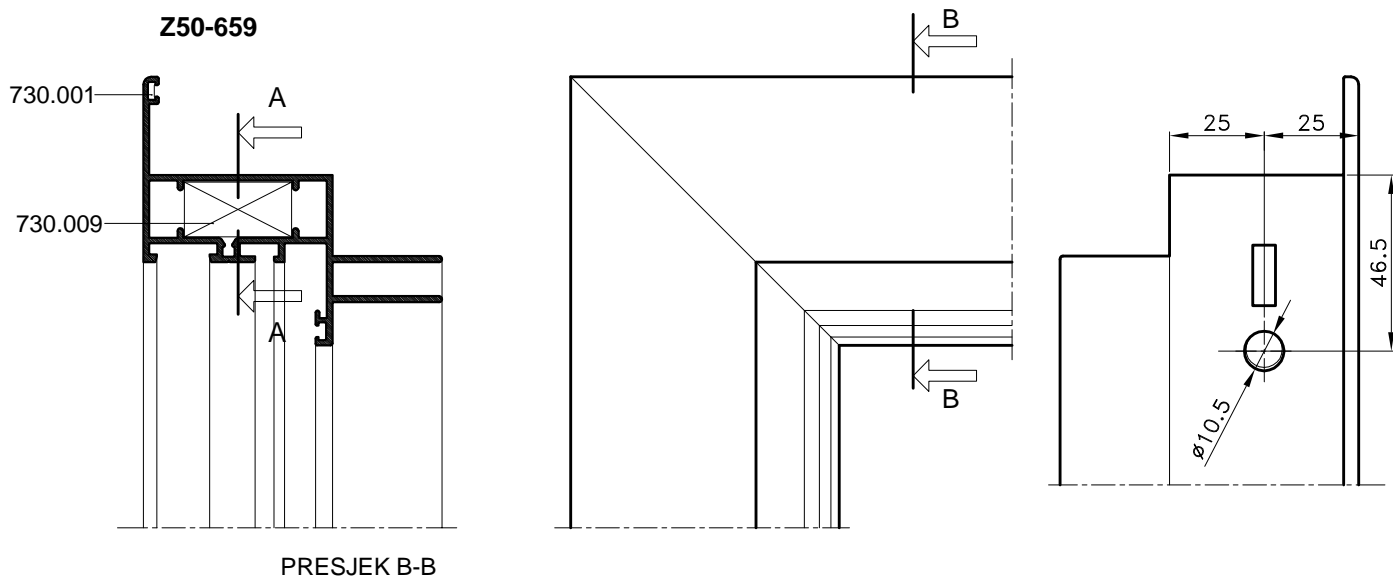

PRESJEK B-B

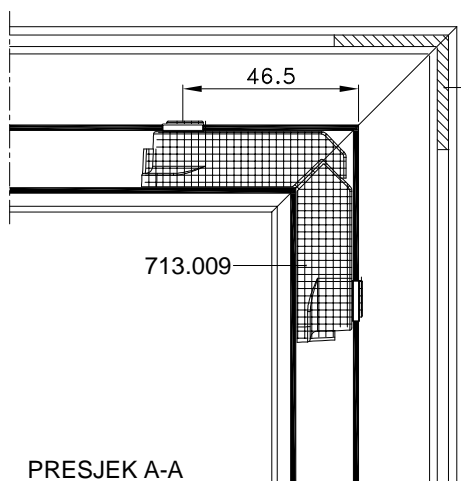

PRESJEK A-A

- 730.001 1. Spajanje kutnikom 730.009 -s predobradom štancanja
- 2. Spajanje kutnikom 730.001

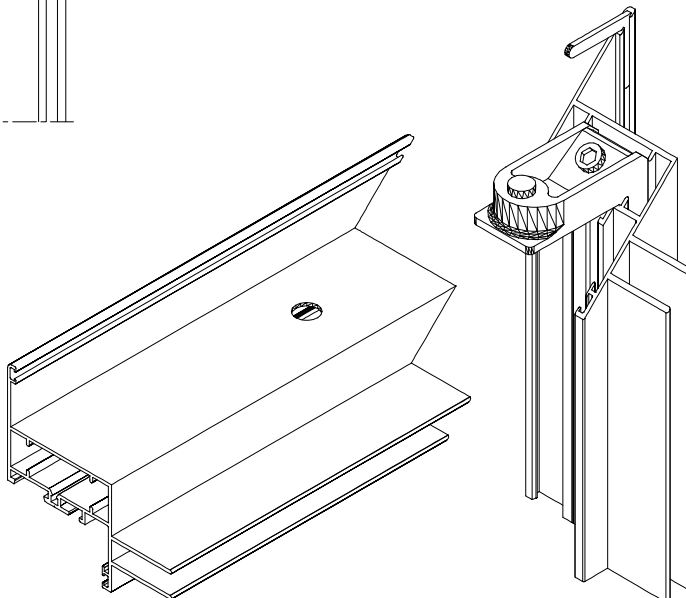

SPAJANJE PROFILA Z50-659 KUTNICIMA

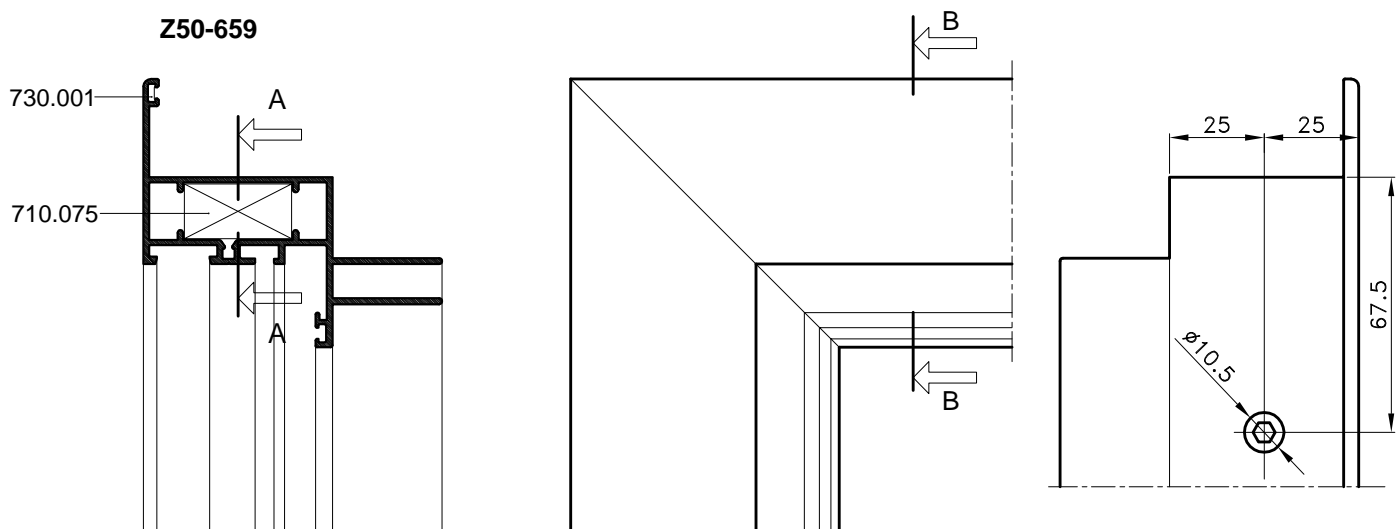

PRESJEK B-B

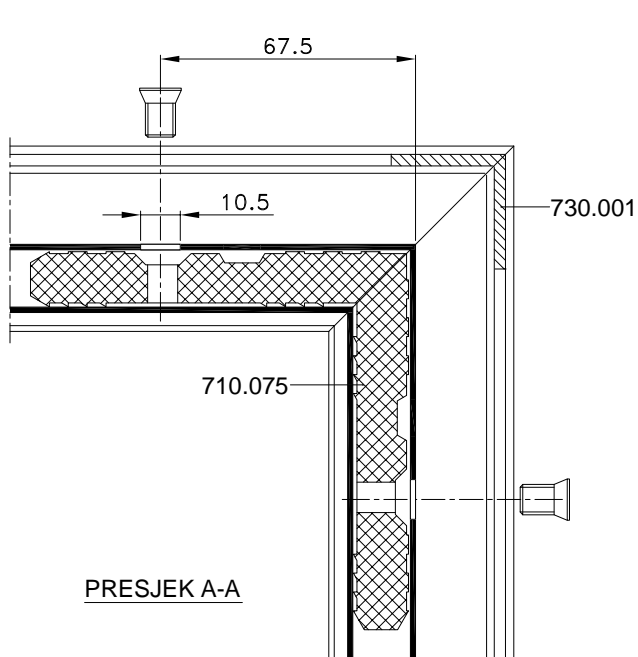

PRESJEK A-A

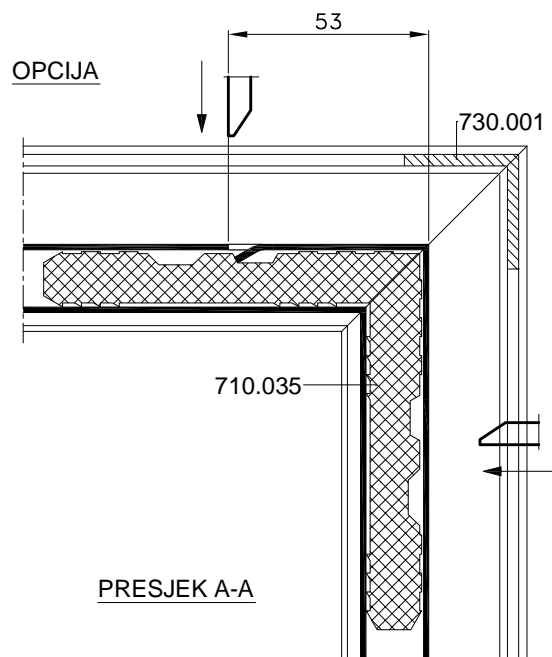

PRESJEK A-A

1. Spajanje kutnikom 710.075 s vijcima M8x13 - tip Feal
2. Spajanje kutnikom 730.001

1. Spajanje kutnikom 710.035 - uprešavanjem
2. Spajanje kutnikom 730.001

SPAJANJE PROFILA Z50-659/30 KUTNICIMA

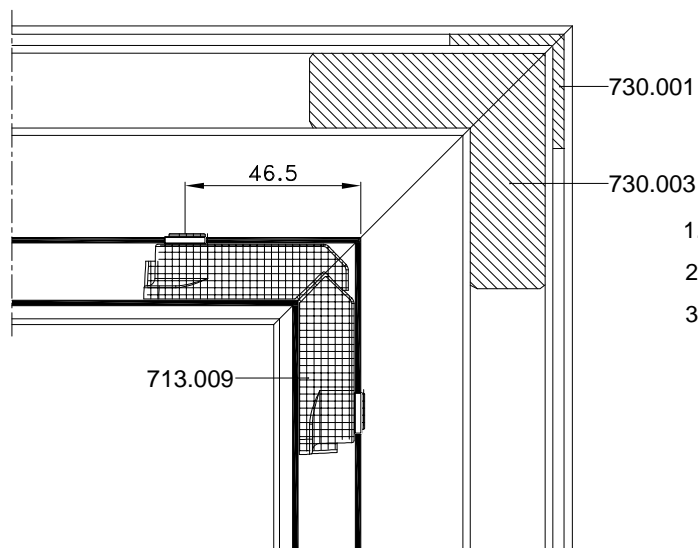
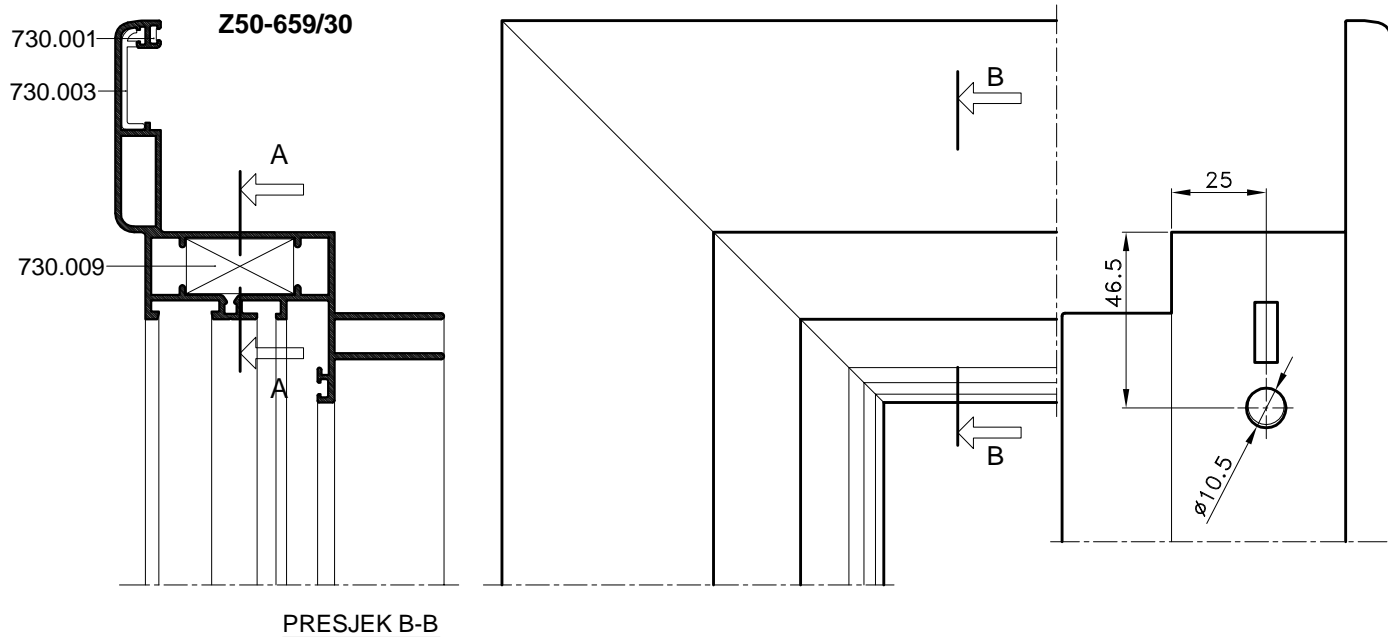

1. Spajanje kutnikom 730.009 -s predobradom štancanja
2. Spajanje kutnikom 730.001
3. Spajanje kutnikom 730.003

PRESJEK A-A

SPAJANJE PROFILA Z50-659/30 KUTNICIMA

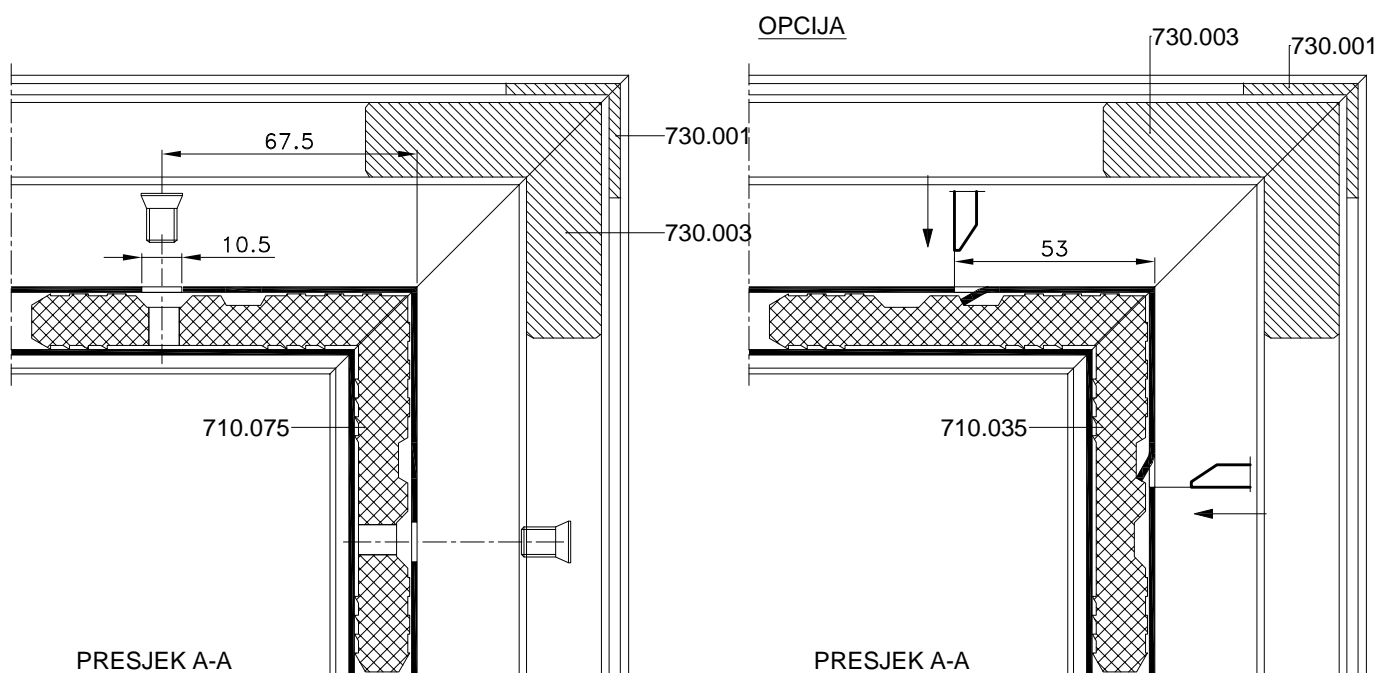
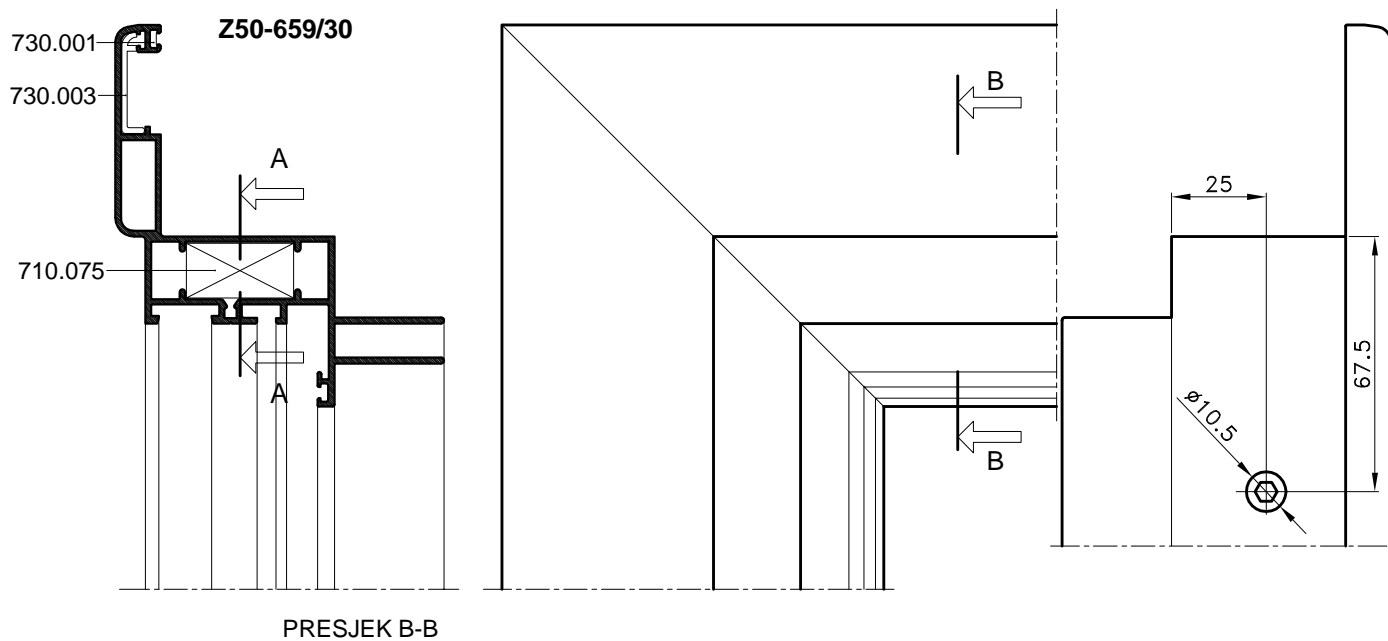

1. Spajanje kutnikom 710.075 -s vijcima M8x13 tip Feal
2. Spajanje kutnikom 730.001
3. Spajanje kutnikom 730.003

1. Spajanje kutnikom 710.035 -uprešavanjem
2. Spajanje kutnikom 730.001
3. Spajanje kutnikom 730.003

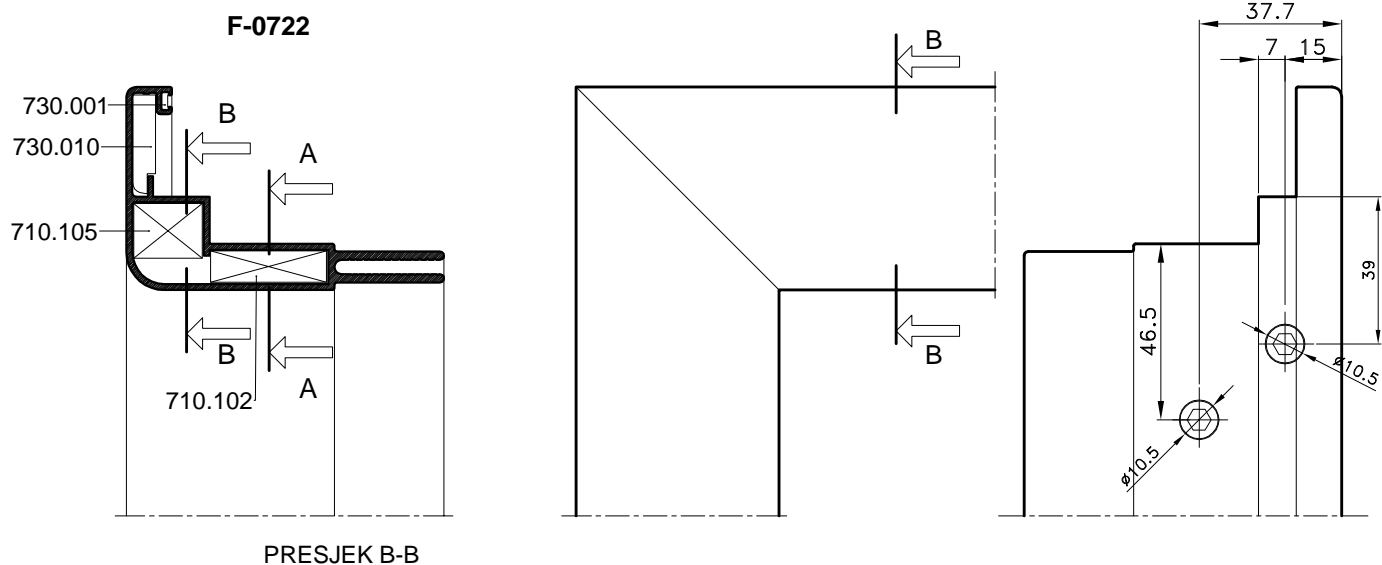
SPAJANJE PROFILA F-0722 KUTNICIMA

PRESJEK B-B

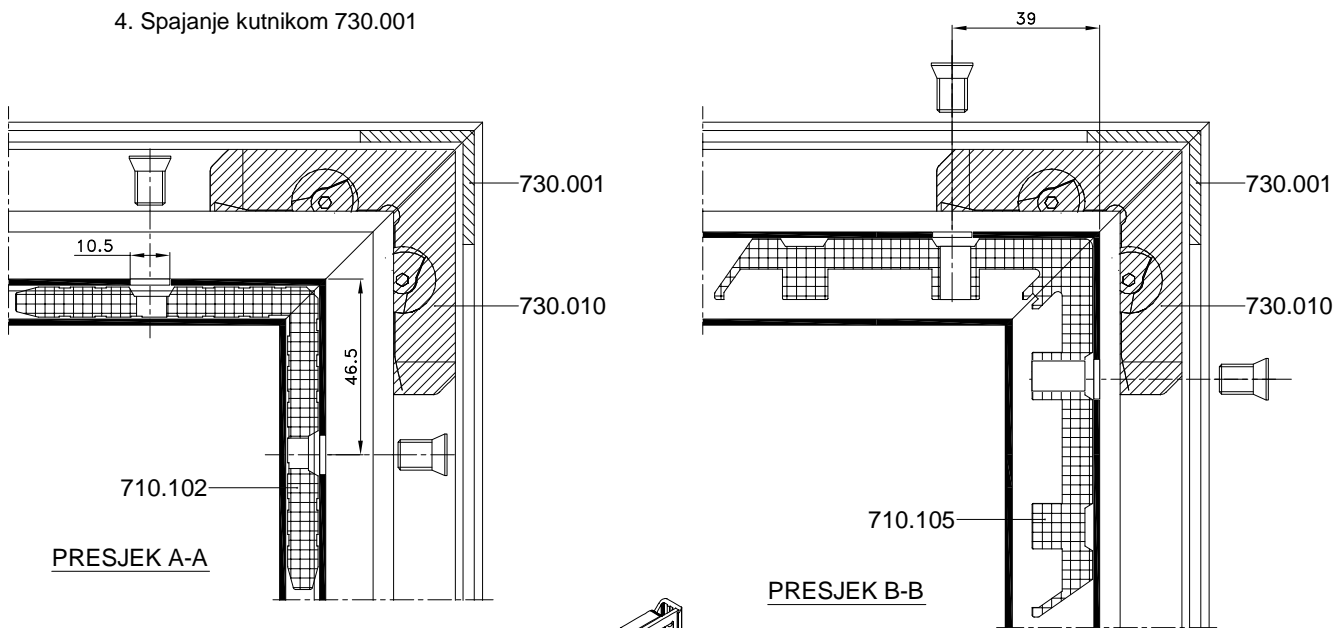
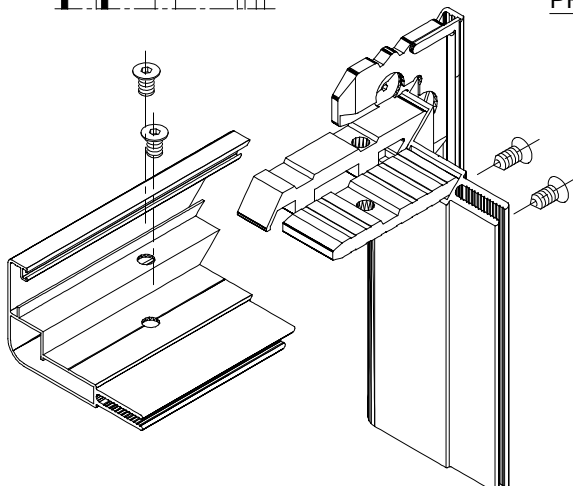
1. Spajanje kutnikom 710.102 - vijcima M8x13 -tip Feal
2. Spajanje kutnikom 710.105 - vijcima M8x13 -tip Feal
3. Spajanje kutnikom 730.010 - zatezanje imbusom
4. Spajanje kutnikom 730.001

PRESJEK A-A
PRESJEK B-B

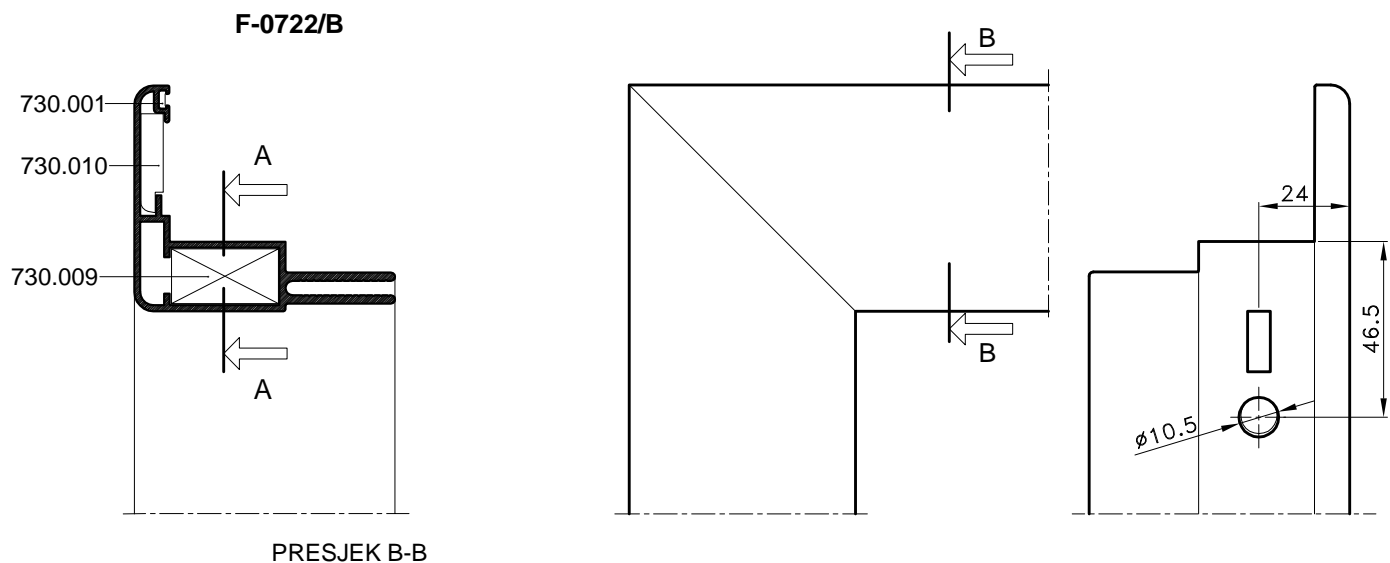
SPAJANJE PROFILA F-0722/B KUTNICIMA



1. Spajanje kutnikom 730.009 - s predobradom štancanja
2. Spajanje kutnikom 730.010 - zatezanje imbusom
3. Spajanje kutnikom 730.001

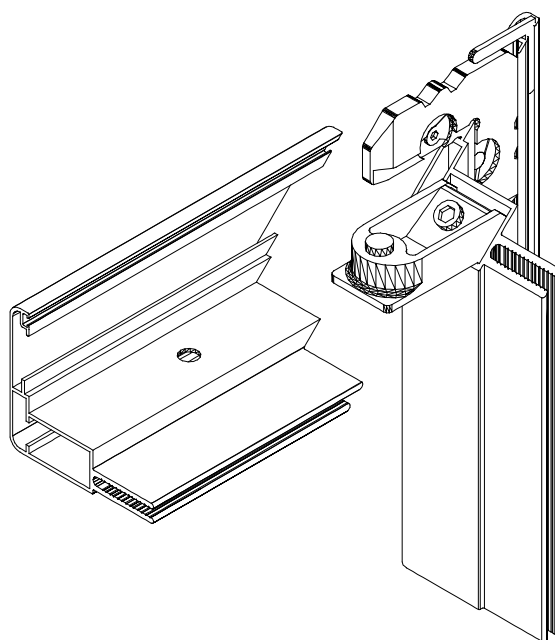
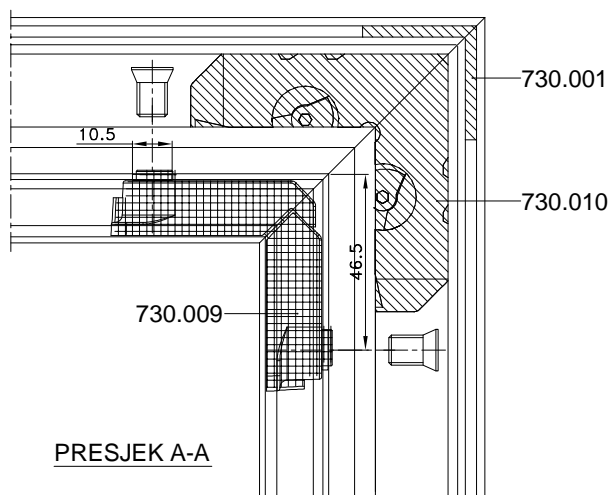

SPAJANJE PROFILA F-0722/B KUTNICIMA

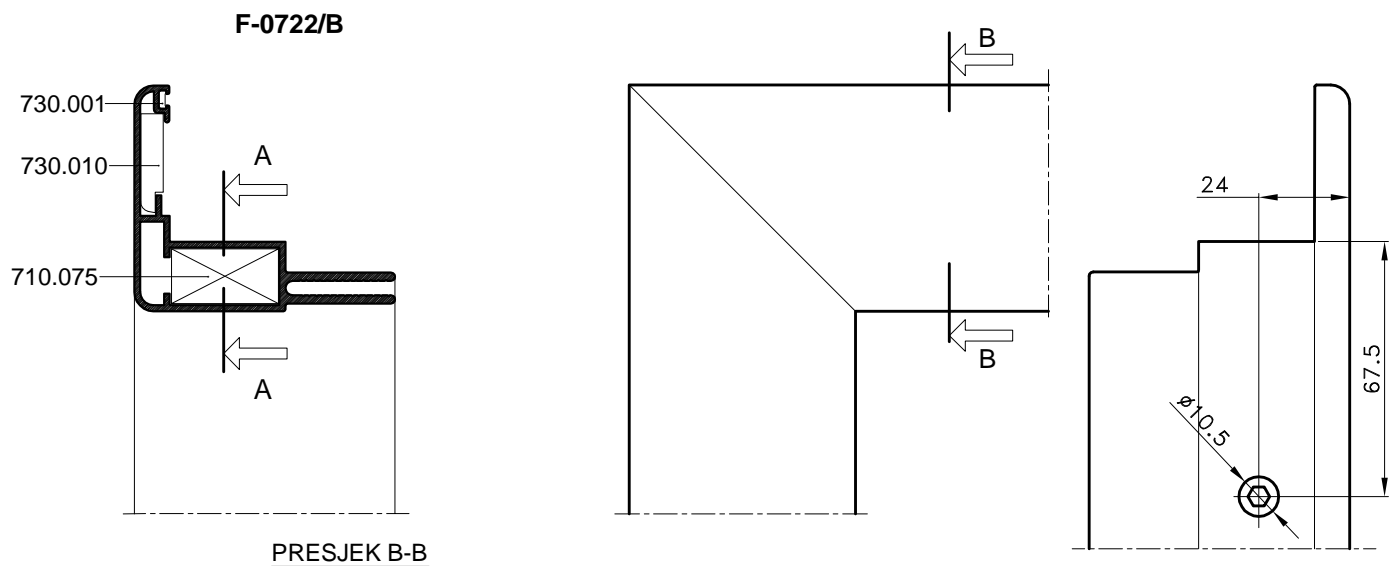

1. Spajanje kutnikom 710.075 - s vijcima M8x13 tip Feal
Opcija: spajanje kutnikom 710.035-uprešavanjem
2. Spajanje kutnikom 730.010 - zatezanje imbusom
3. Spajanje kutnikom 730.001

OPCIJA

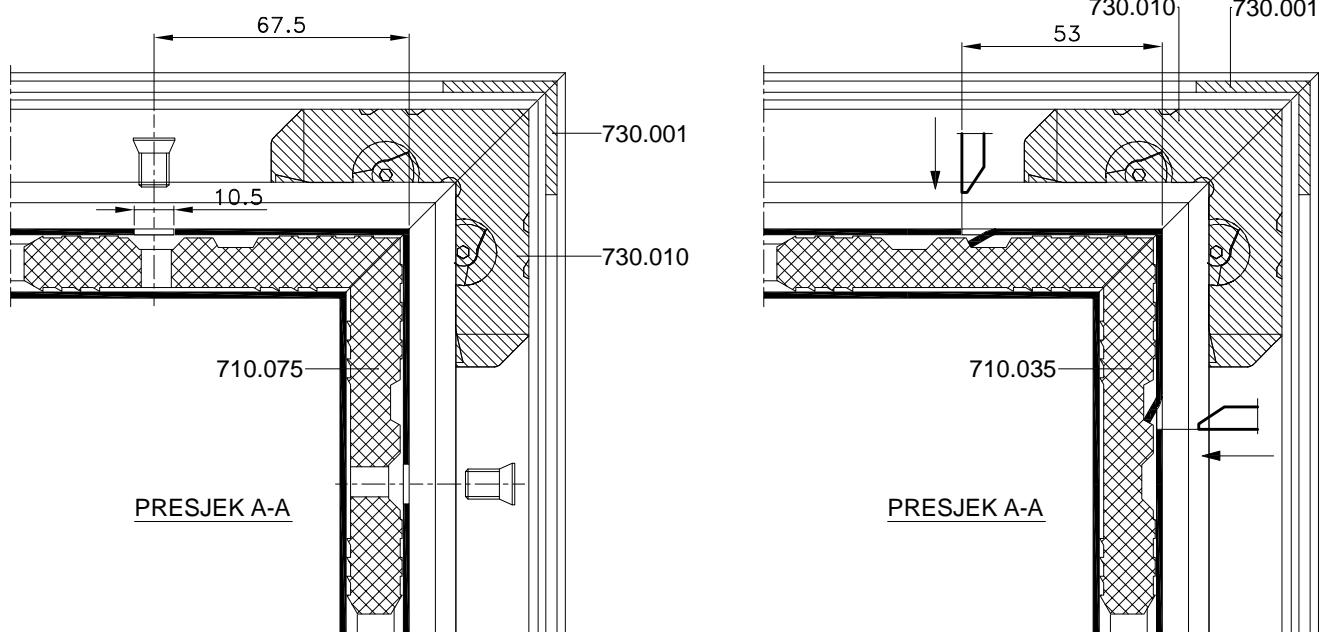

SPAJANJE PROFILA F-0722/A KUTNICIMA

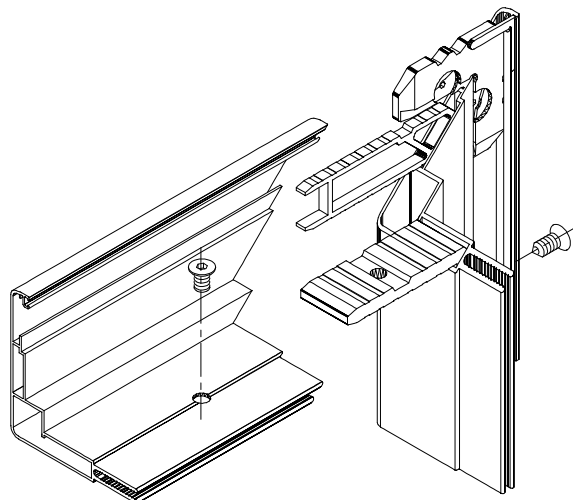
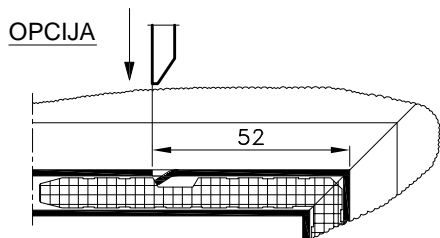
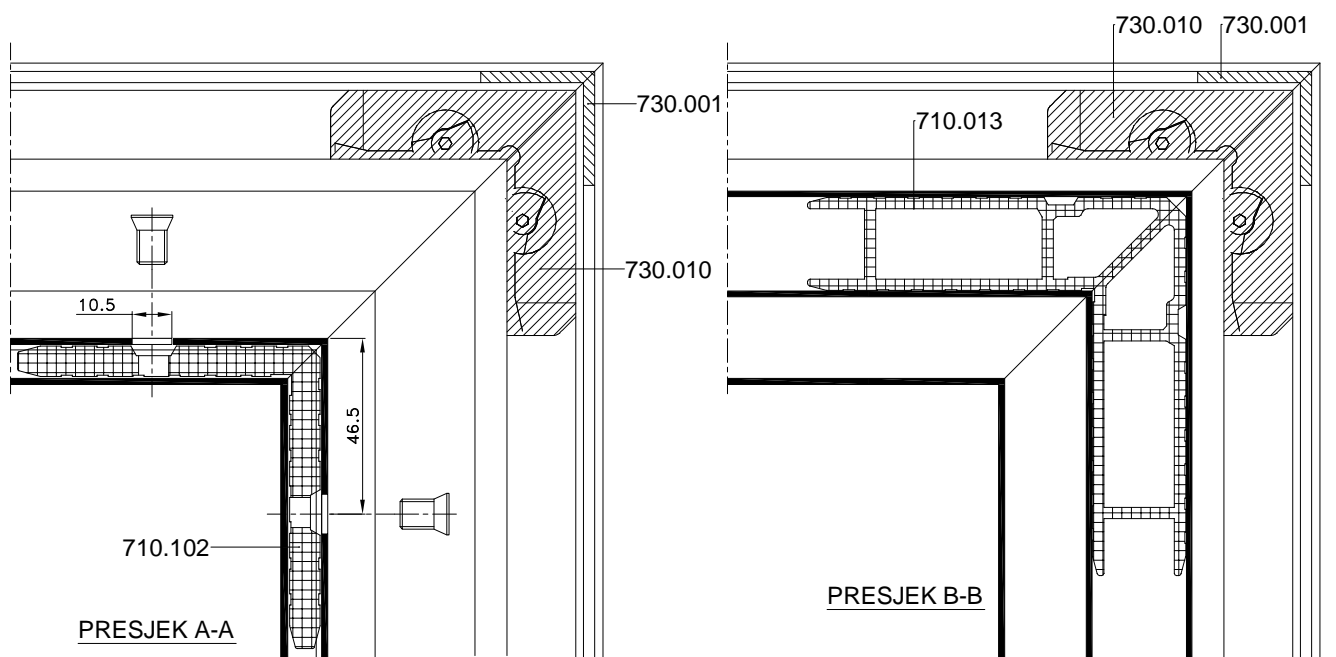
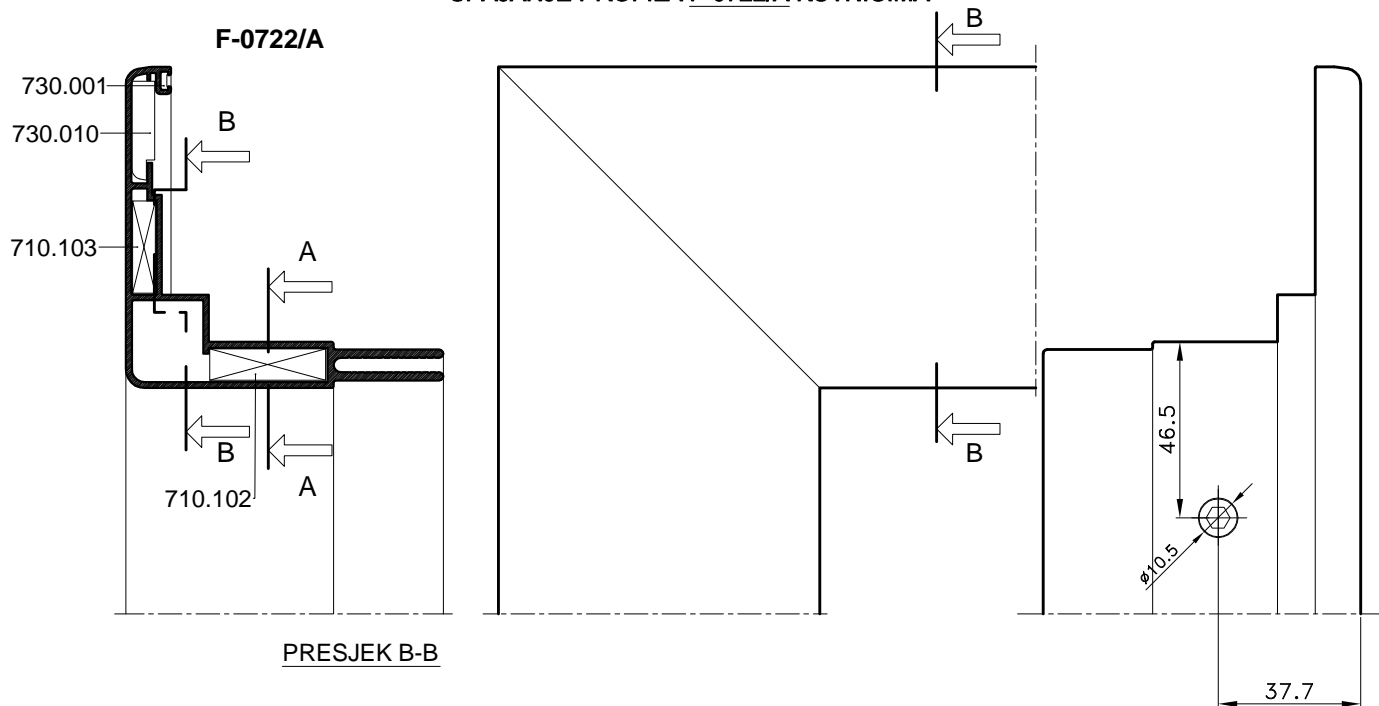

1. Spajanje kutnikom 710.102 - vijcima M8x13 -tip Feal
Opcija: spajanje kutnikom 710.102-uprešavanjem
2. Spajanje kutnikom 710.103 - vijcima M8x13 -tip Feal
3. Spajanje kutnikom 730.010 - zatezanje imbusom
4. Spajanje kutnikom 730.001

OBRADA ZA VRATA SA STAKLENIM I DRVENIM KRILOM

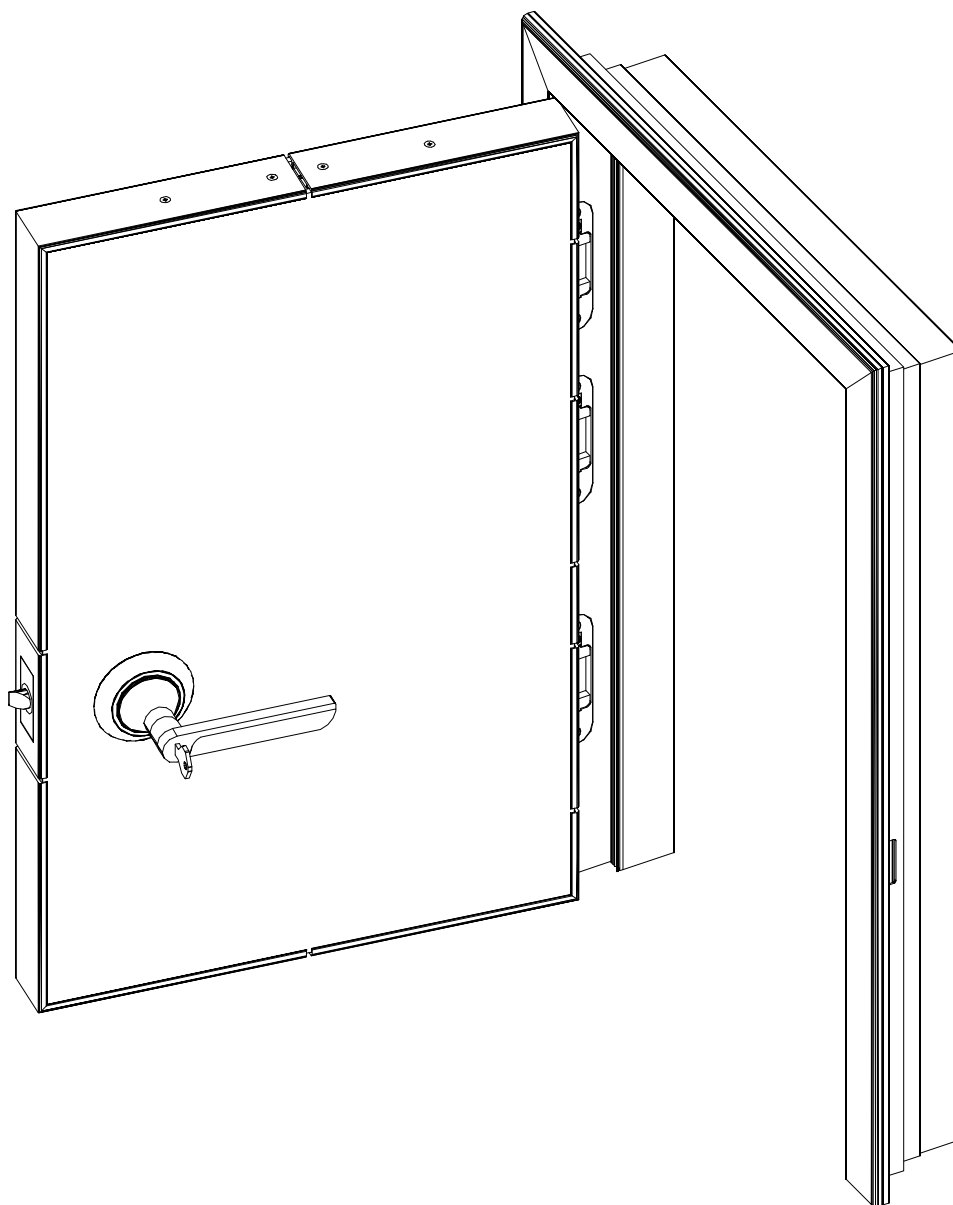

STAKLENA VRATA

-Spajanje okvira krila vrata od profila **F-1102** kutnicima **710.057** (K-0795/E)

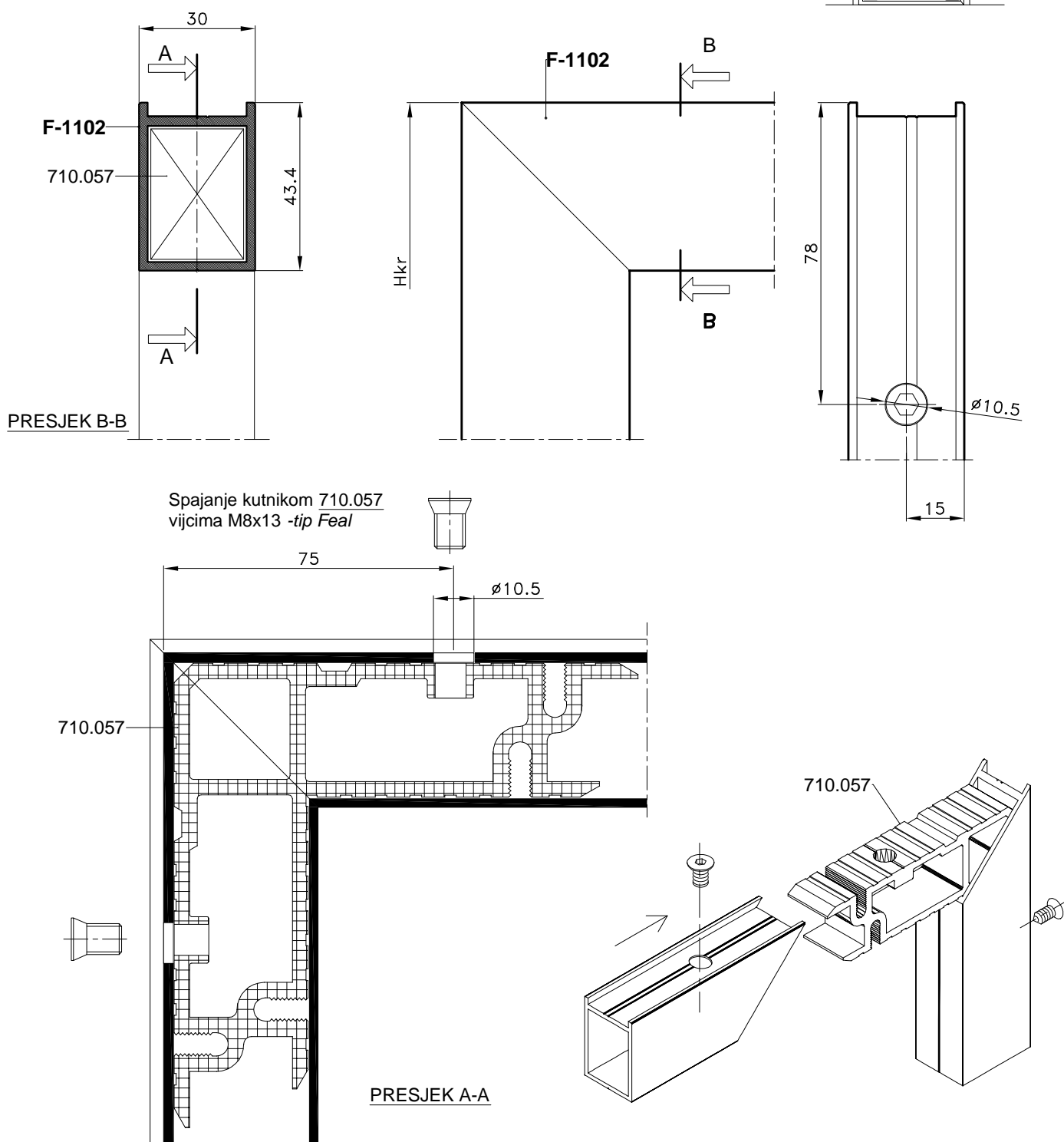
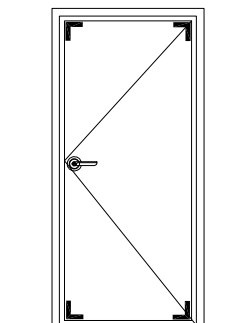

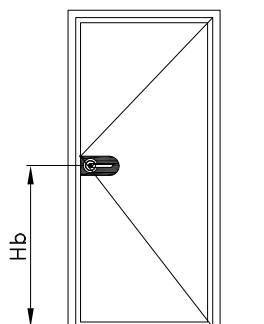

OBRADA ZA BRAVU

-Obrada za bravu Hoppe HCS-120.000

-Umetak za prihvat brave - u slučaju korištenja prozirne ispune (umetak se radi od profila F-0177(30x100) i F-0512(Ø100) prema crtežu te se na kraju zavari i fino prebrusi radi lijepljenja stakla i vidljivosti

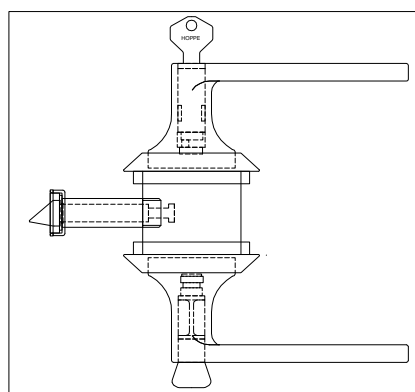
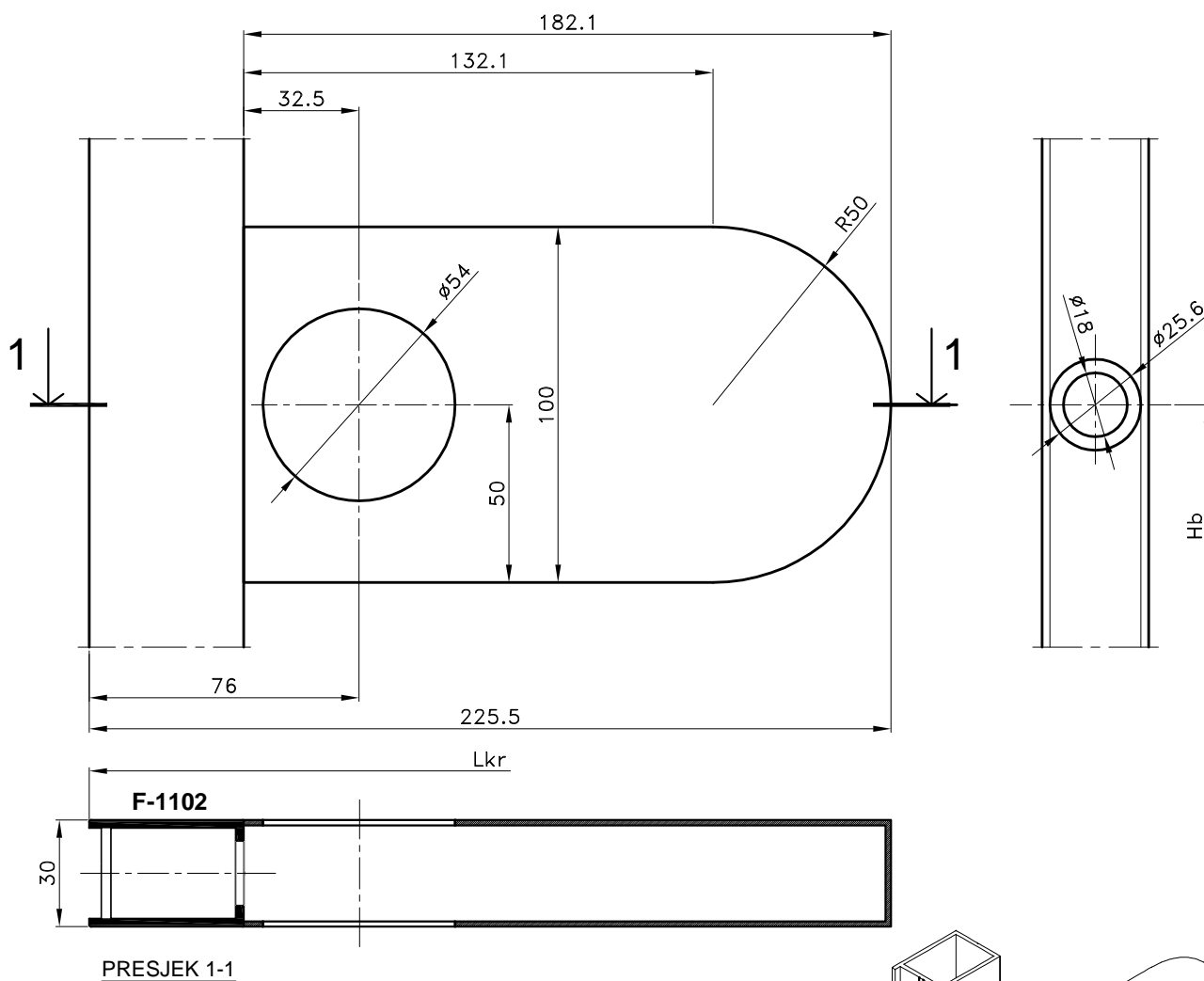

brava Hoppe HCS
s jezičkom i prihvatnikom
jezička

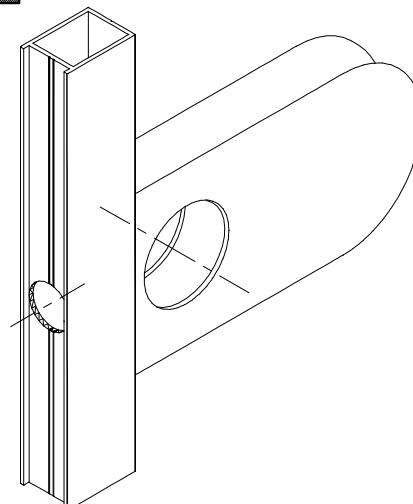

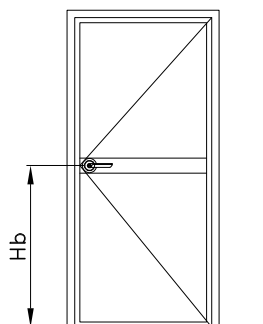

UGRADNJA PREČKE-OBRADA ZA BRAVU

-Obrada za bravu Hoppe HCS-120.000

-Umetak za prihvat brave - u slučaju korištenja neprozirne ispune (umetak se radi kao prečka krila vrata od profila F-0201(30x60) a za veznike se koriste komadi art. SP01 i SP02).

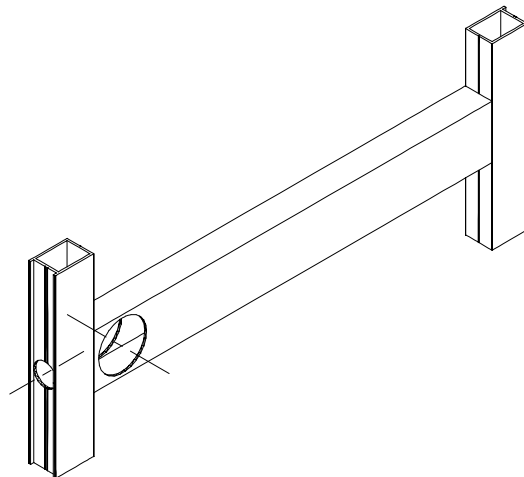
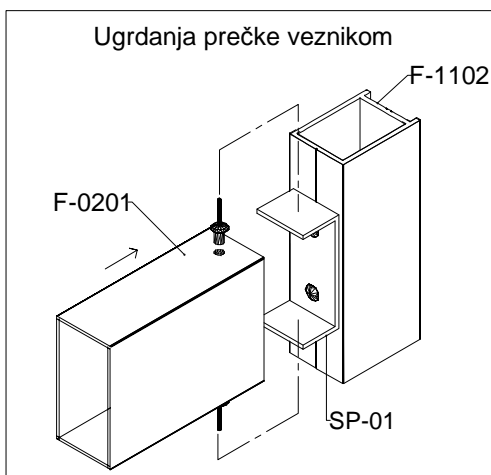
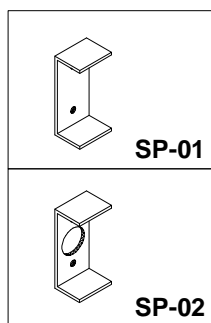
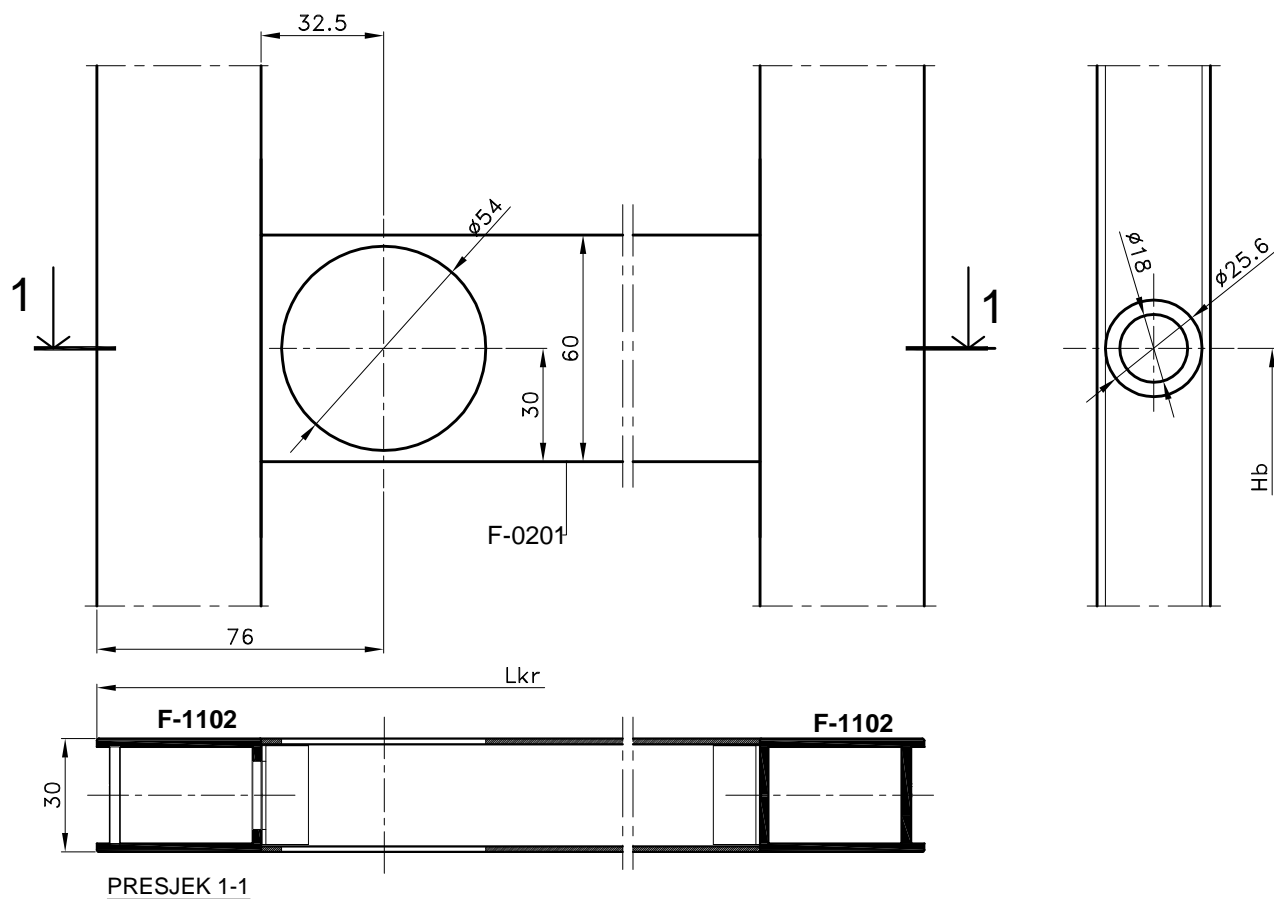

OBRADA NA PROFILU **F-1011**

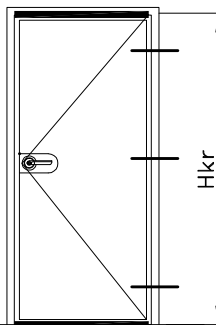

GORNJA LAJSNA

DONJA LAJSNA

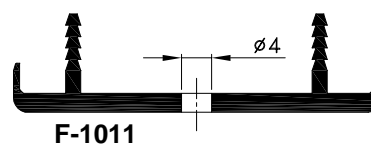
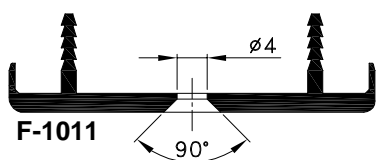
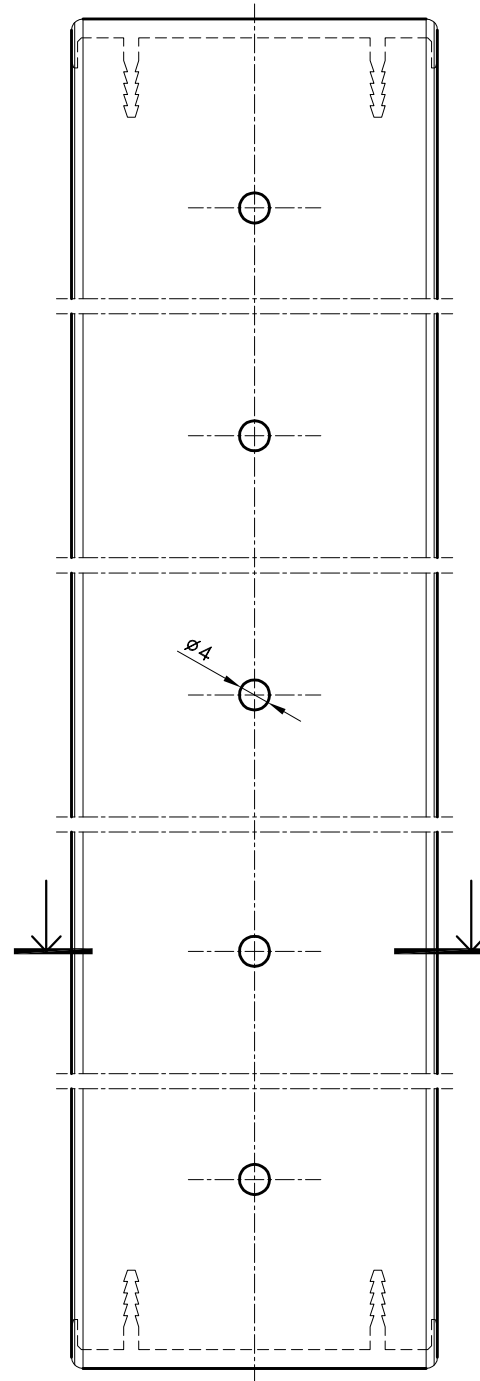
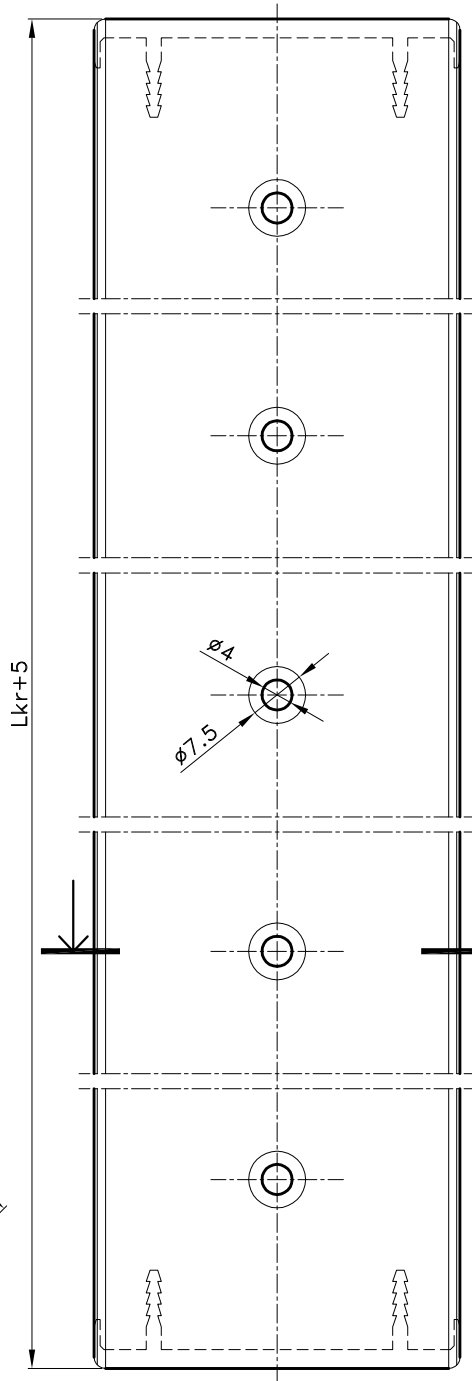
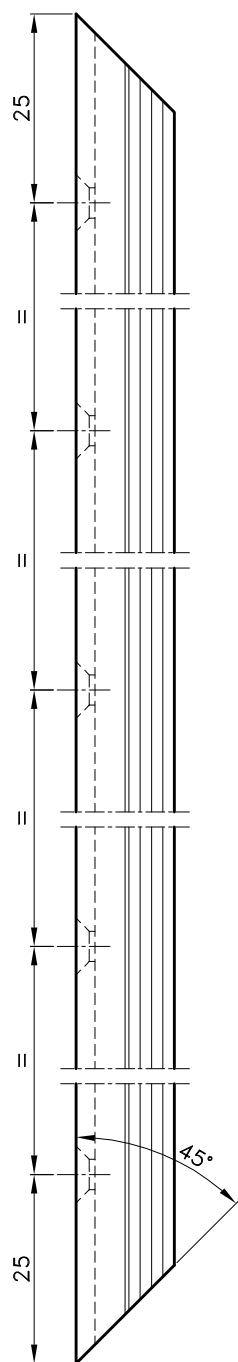

OBRADA NA PROFILU **F-1011**

OKOMITA LAJSNA -
obrada za bravu

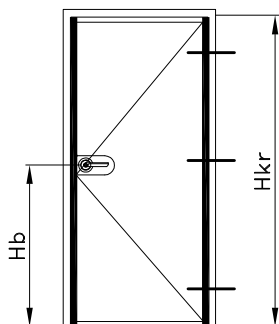

OKOMITA LAJSNA -
obrada za baglamu

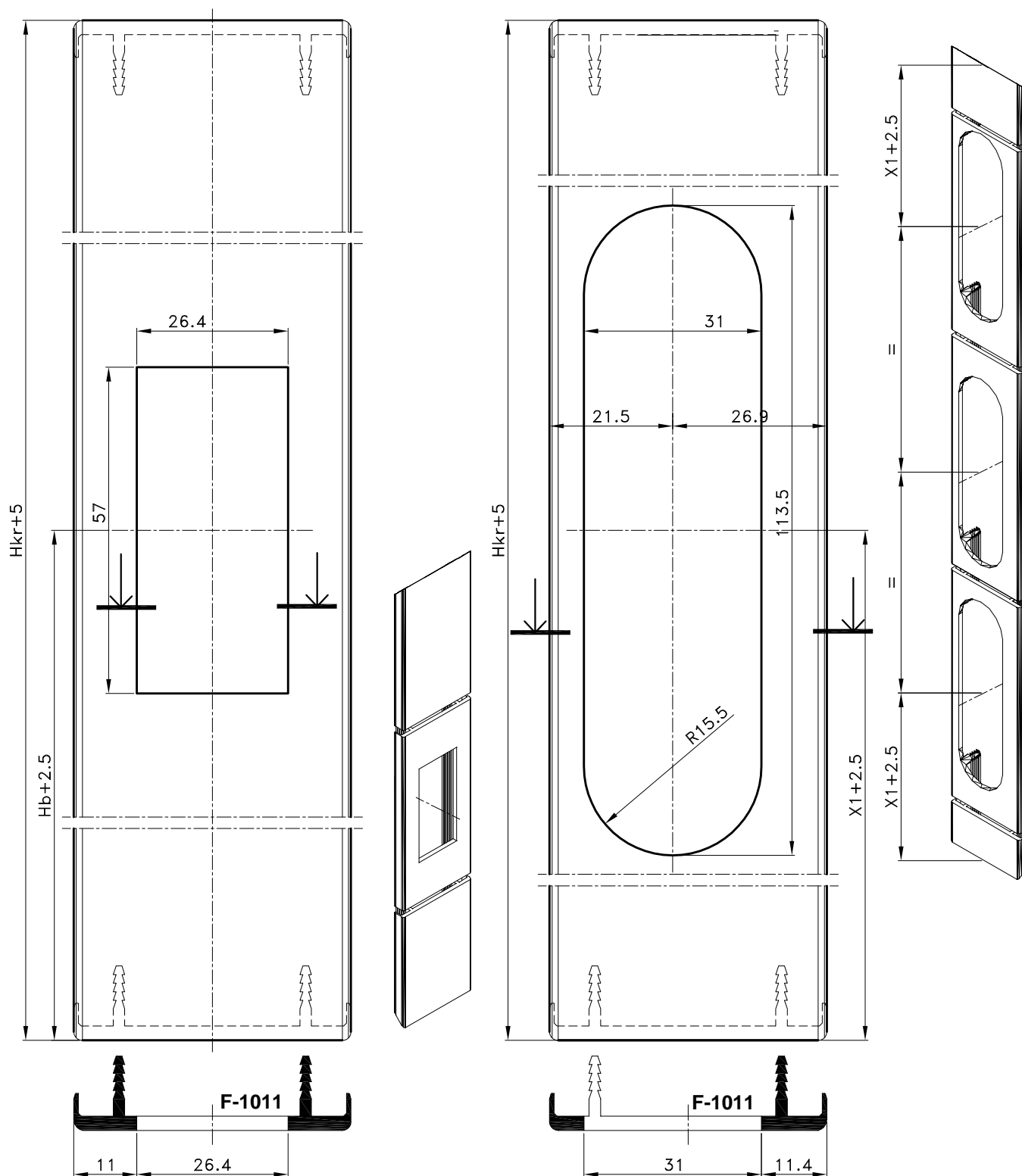

OBRADA NA PROFILU **P45-644** - držač četkica

1. RASPILAVANJE
2. OBRADA ZA VIJKE

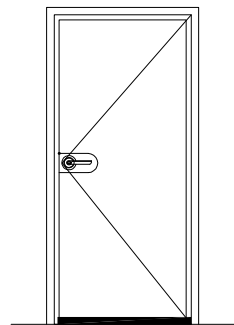

1. RASPILAVANJE

2. OBRADA ZA VIJKE

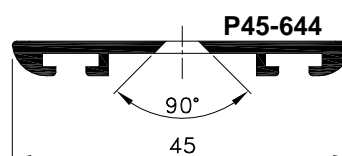
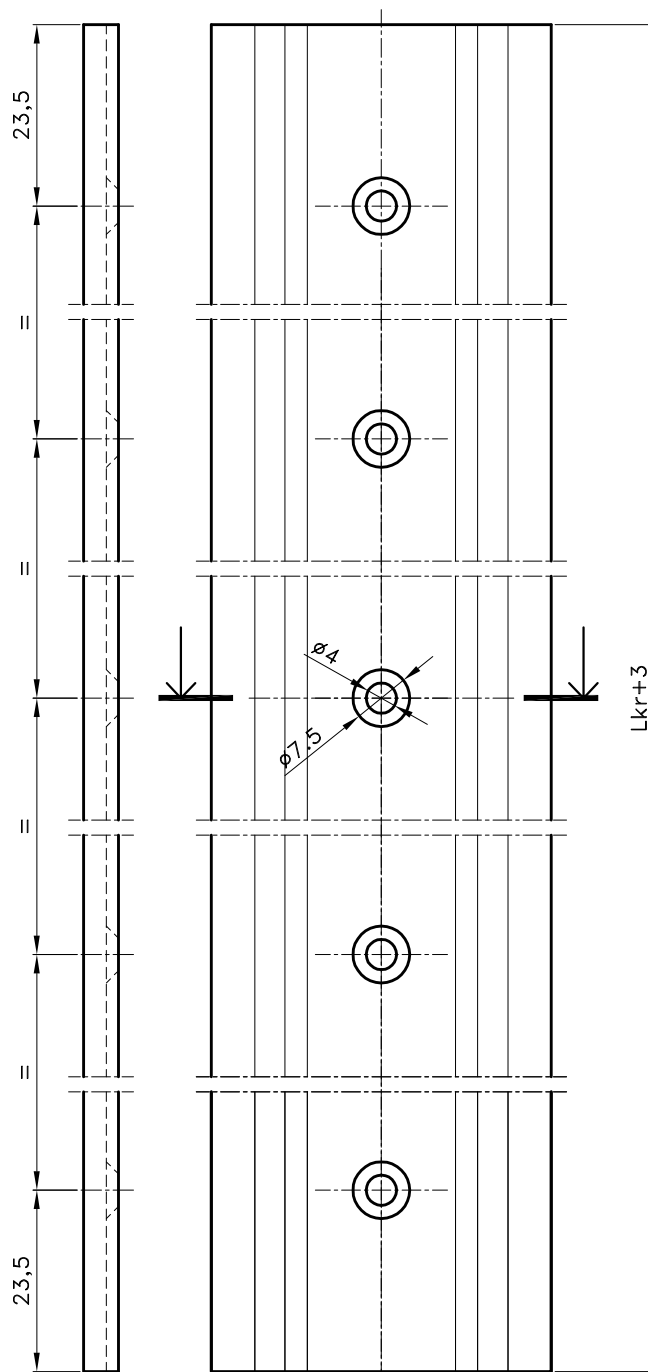
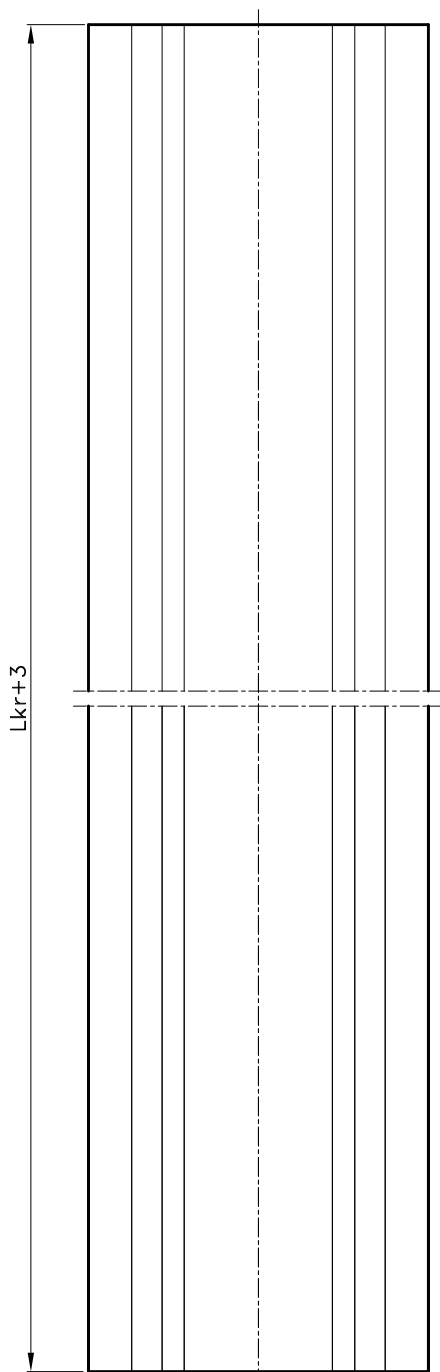

OBRADA PROFILA KRILA DRVENIH VRATA
ZA PRIHVAT NEVIDLJIVIH BAGLAMA 110.002

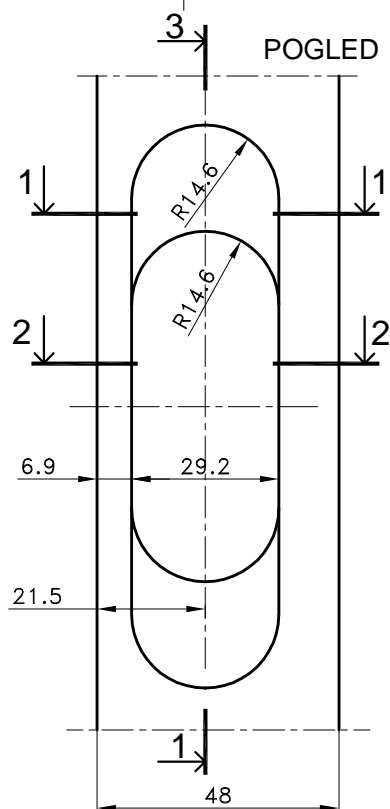
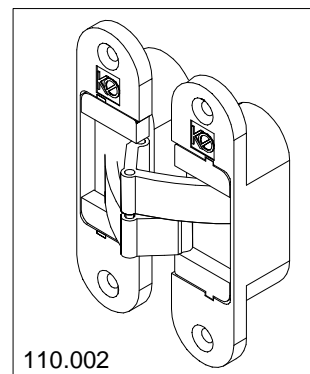
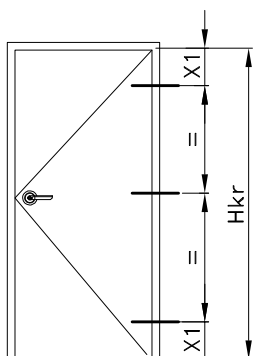

PRESJEK 3-3

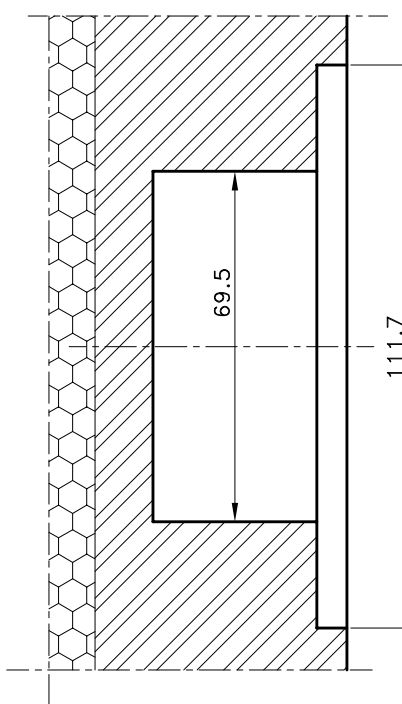

PRESJEK 1-1

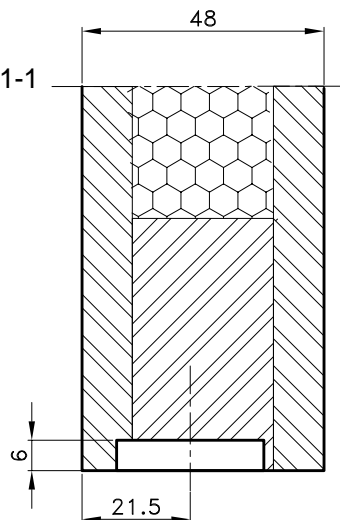

PRESJEK 2-2

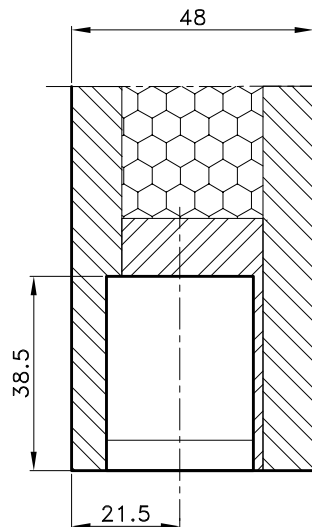

OBRADA PROFILA KRILA DRVENIH VRATA
ZA PRIHVAT BRAVE Hoppe HCS-120.000

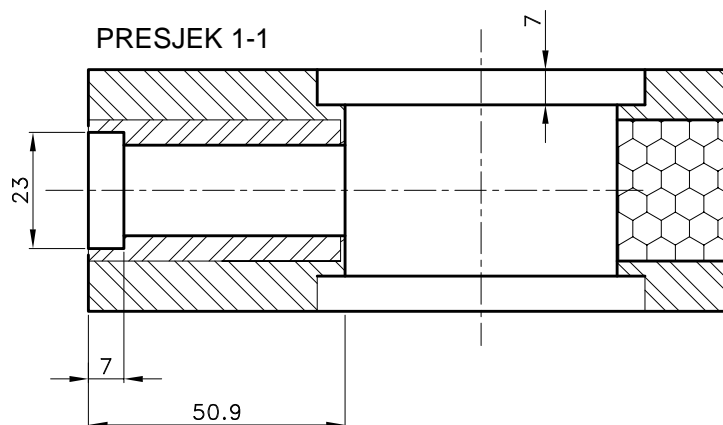
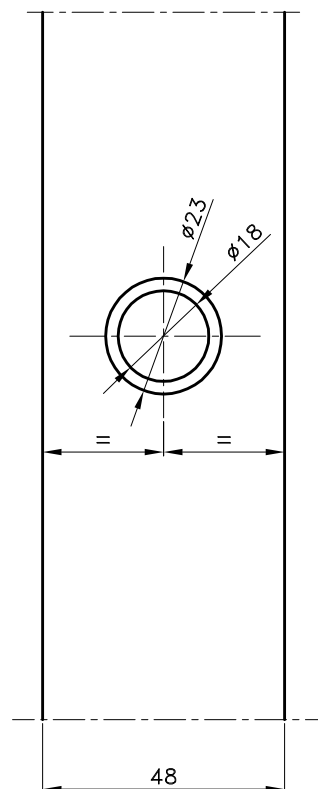
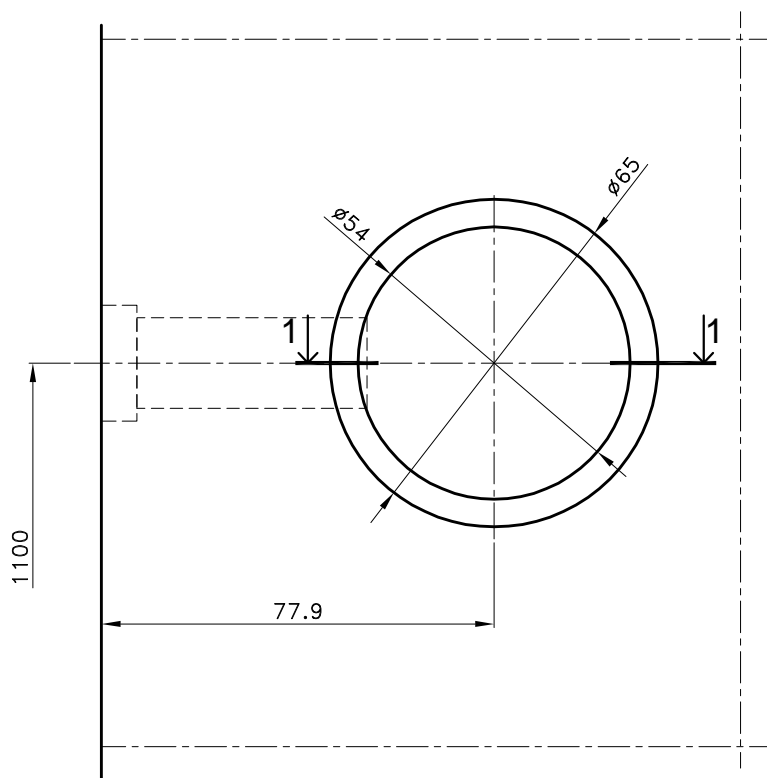
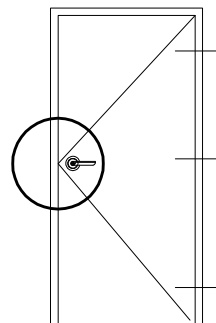

OBRADA PROFILA DOVRATNIKA F-0721
ZA PRIHVAT NEVIDLJIVIH BAGLAMA 110.002

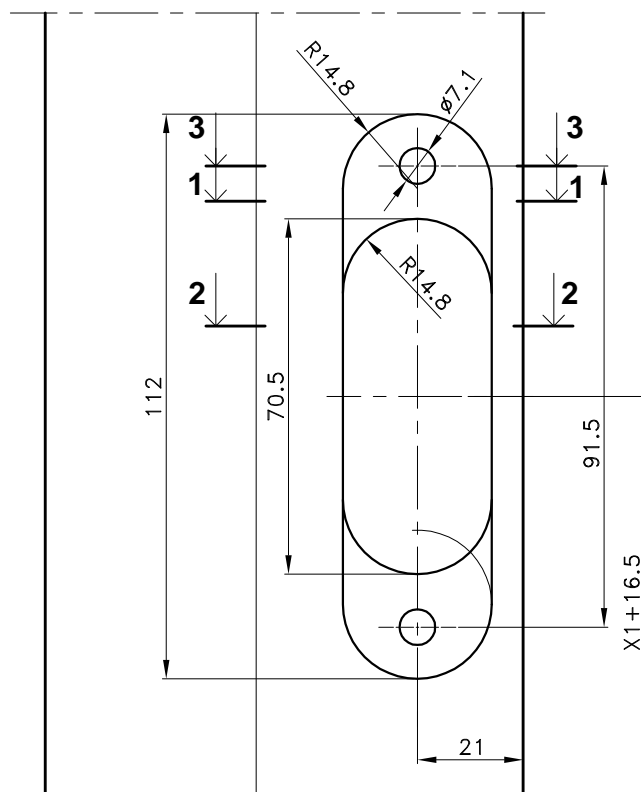
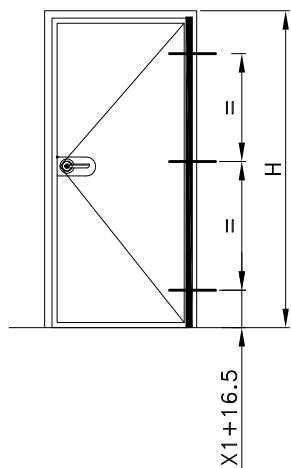

UGRADNJA ZAKIVNE MATICE

-zakivna matica 434.051 (M5x16.5)

-podmetač za baglamu 521.105

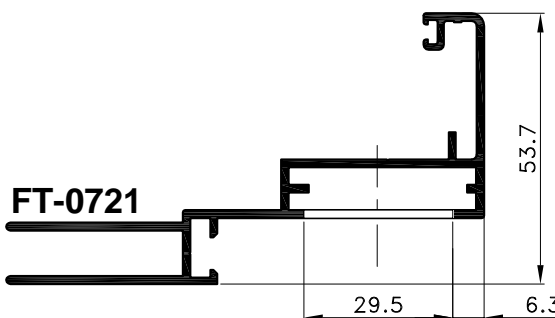
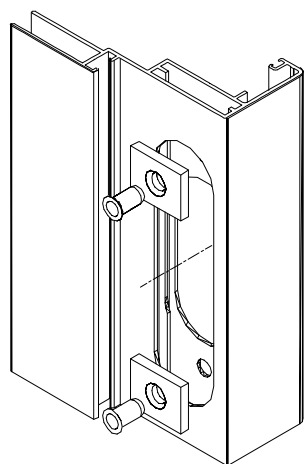
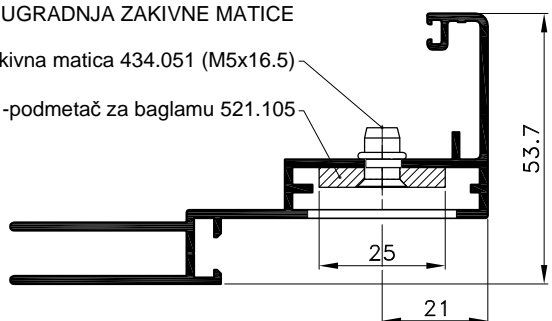

PRESJEK 1-1

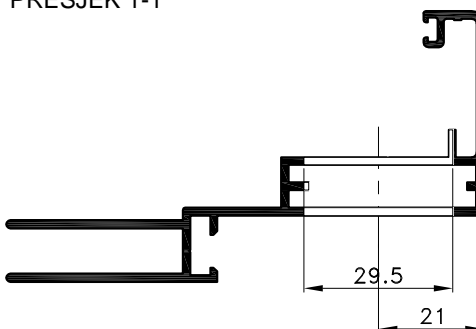

PRESJEK 2-2

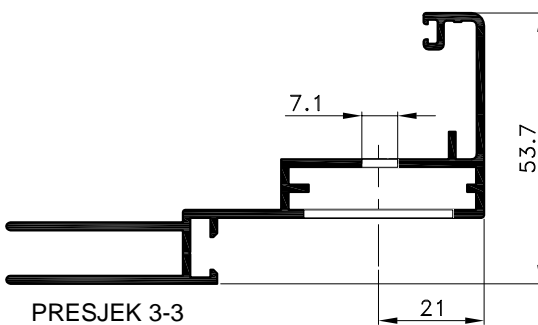

PRESJEK 3-3

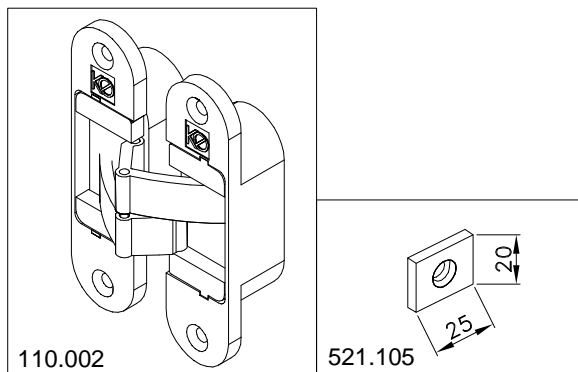

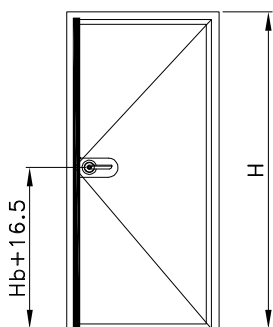

OBRADA PROFILA DOVRATNIKA F-0721
ZA PRIHVATNIK JEZIČKA BAGLAME, S PODMETAČEM

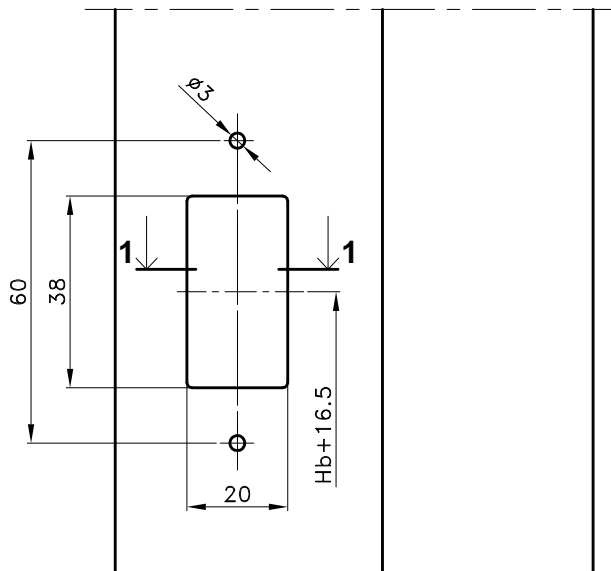

UGRADNJA PRIHVATNIKA JEZIČKA BAGLAME
S PODMETAČEM

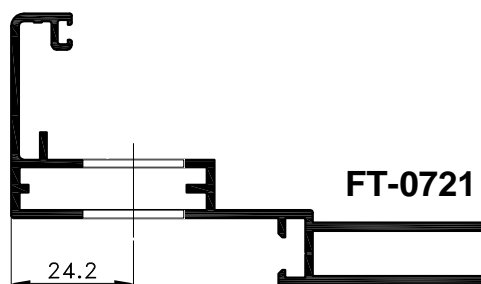
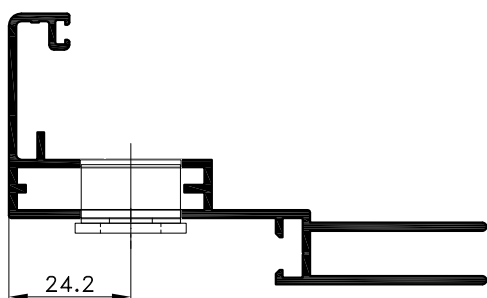

PRESJEK 1-1

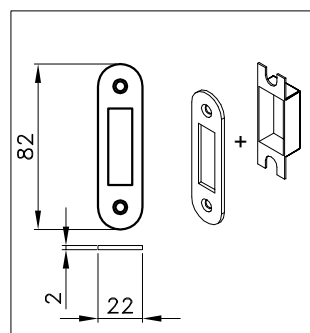
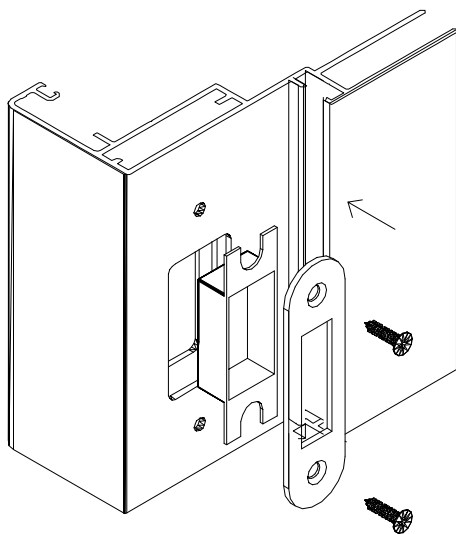

Prihvatnik-šild HCS-SB-E F 69
s podmetačem

OBRADA NA STAKLU ZA VRATA, ZA BRAVU HOOPE

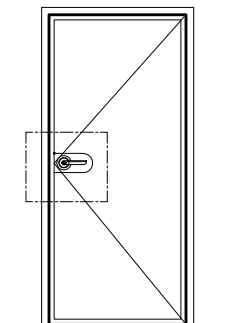

- Na staklu se radi obrada za bravu (rozetu)
- Staklo se emajlira (kali) da se sakrije rubna površina lijepljenja stakla i aluminijska, a emajlirana strana stakla ide prema unutra radi mogućih oštećenja emajla
- Debljina stakla $d=5$ mm
- Stakla su simetrična: lijevo i desno

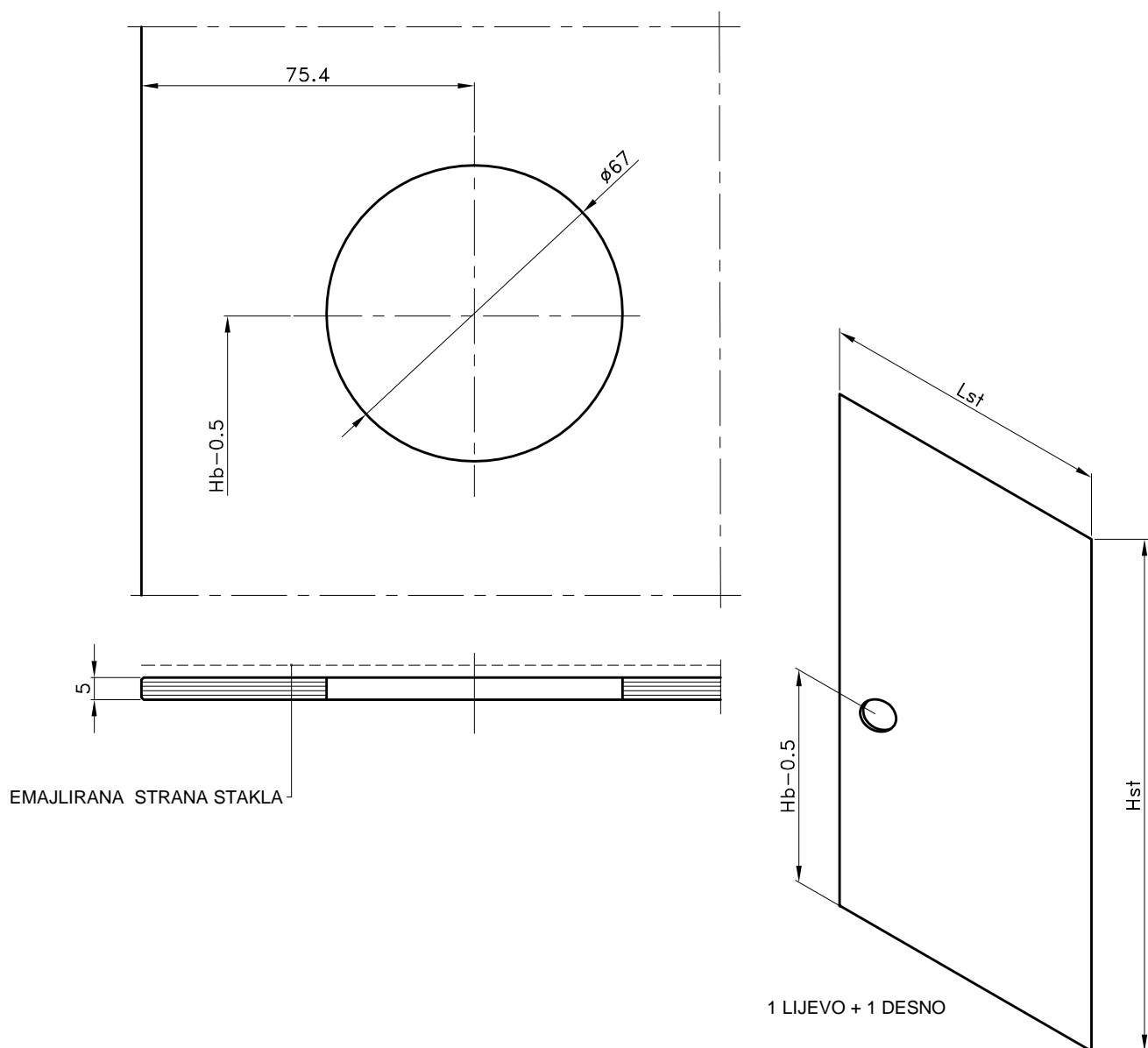

KLJUČANJE POMOĆNOG KRILA KRAKUNOM 124.006

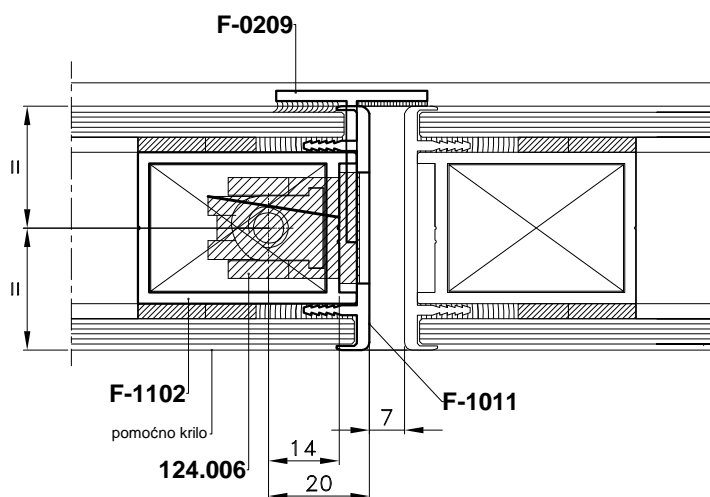
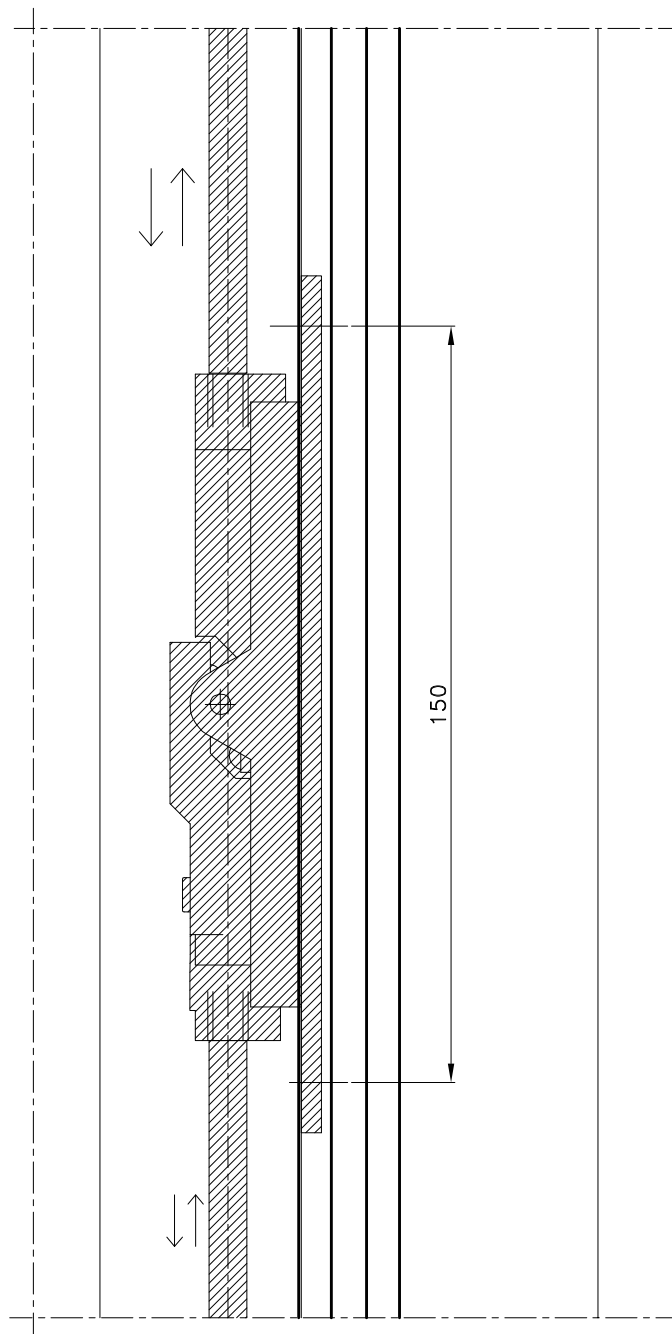
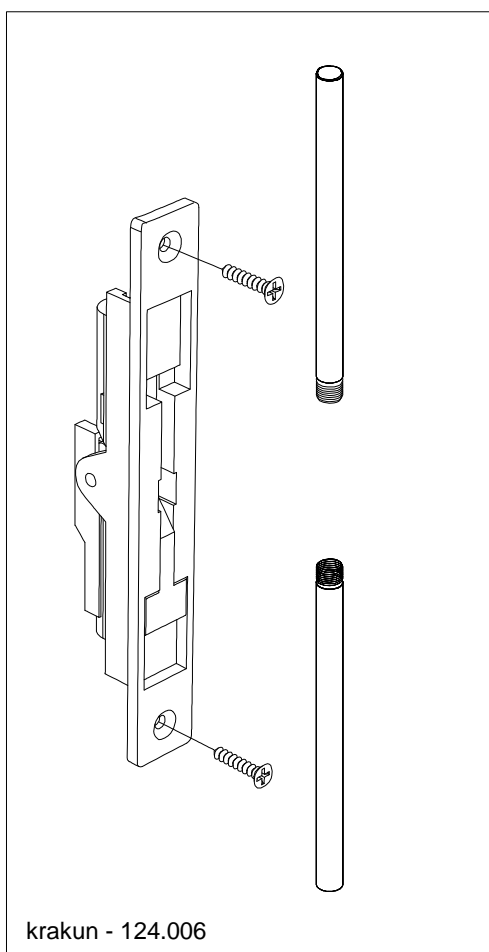
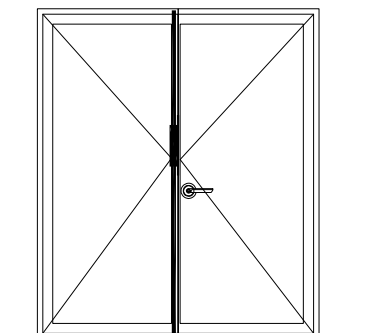

OBRADA PROFILA F-1102
 -ZA ŠILD I KRAKUN KOD DVOKRILNIH VRATA - POMOĆNO KRILO

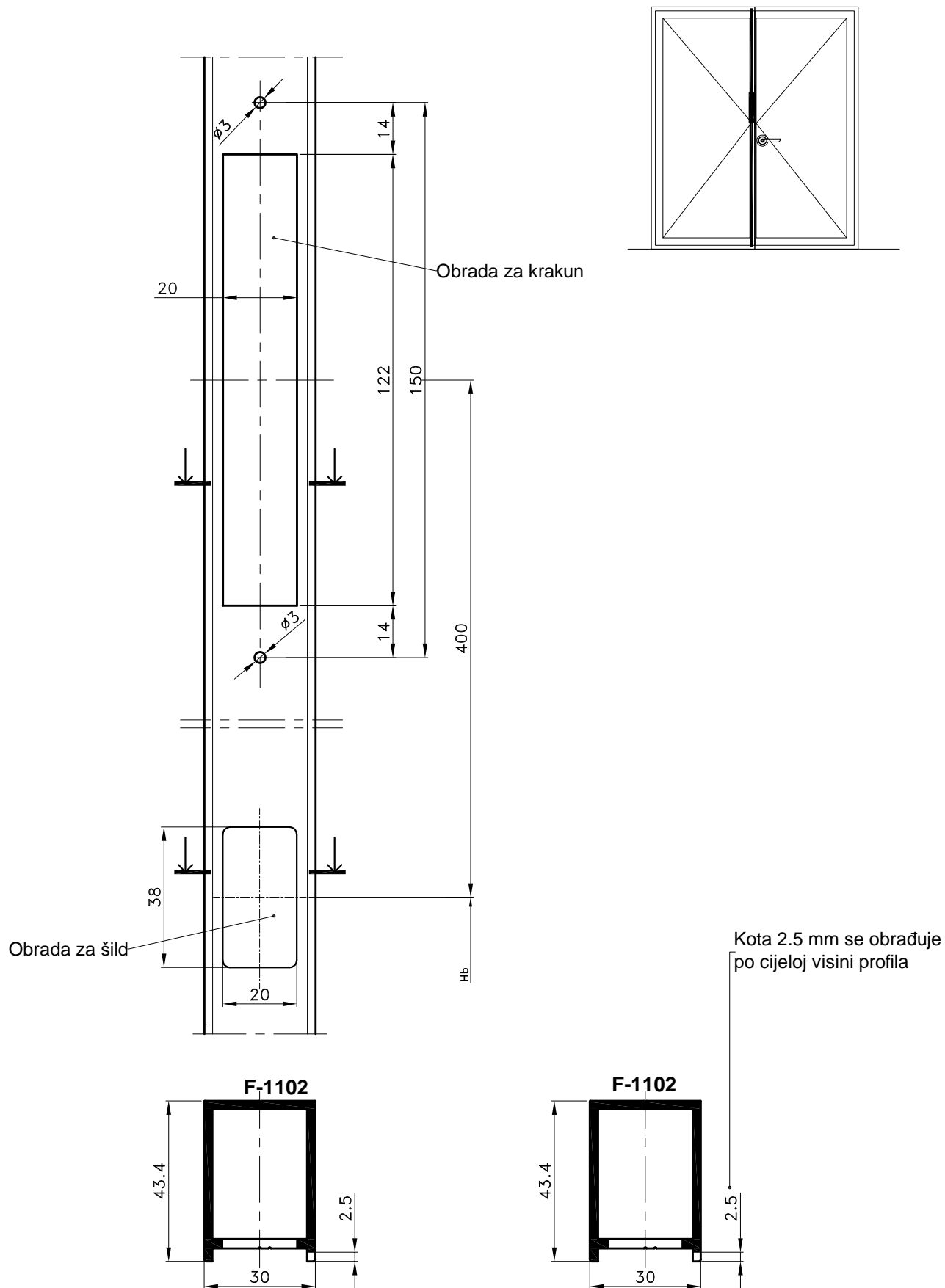

OBRADA PROFILA F-1011
 -ZA ŠILD I KRAKUN KOD DVOKRILNIH VRATA - POMOĆNO KRILO

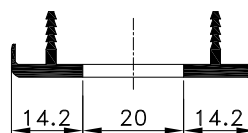
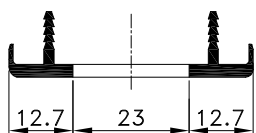
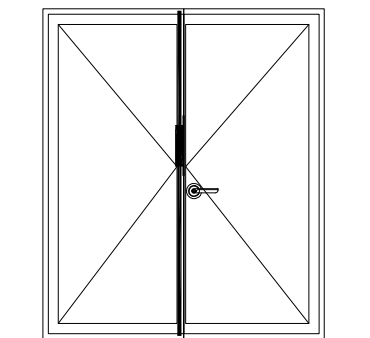
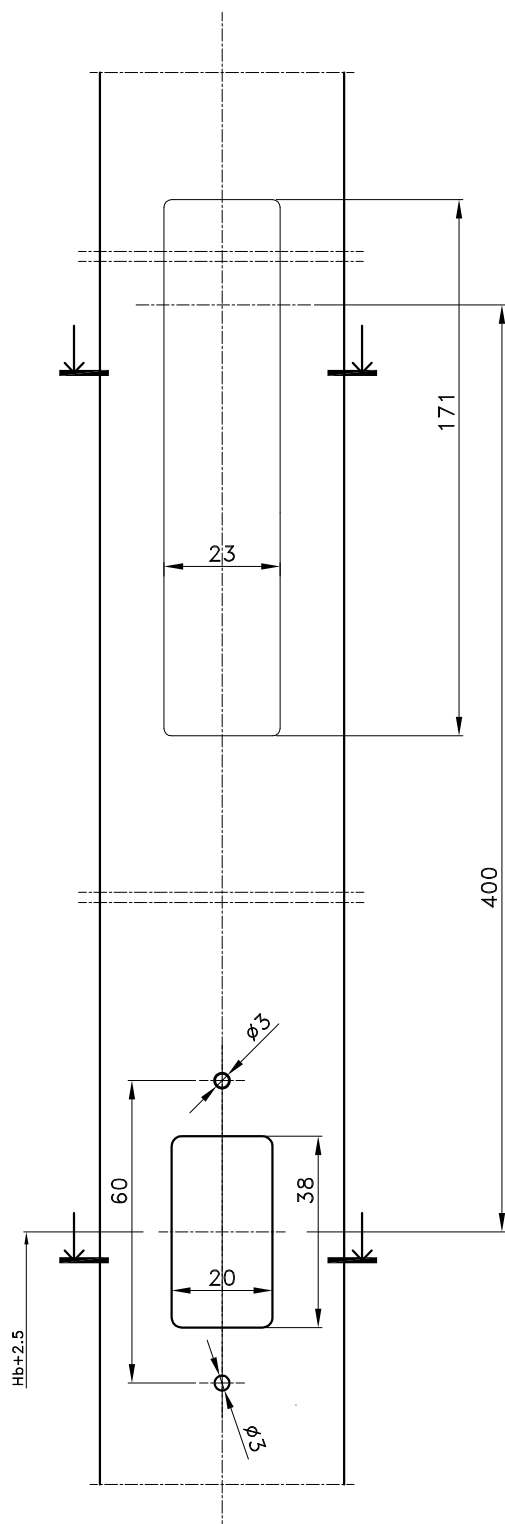

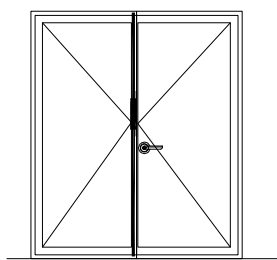
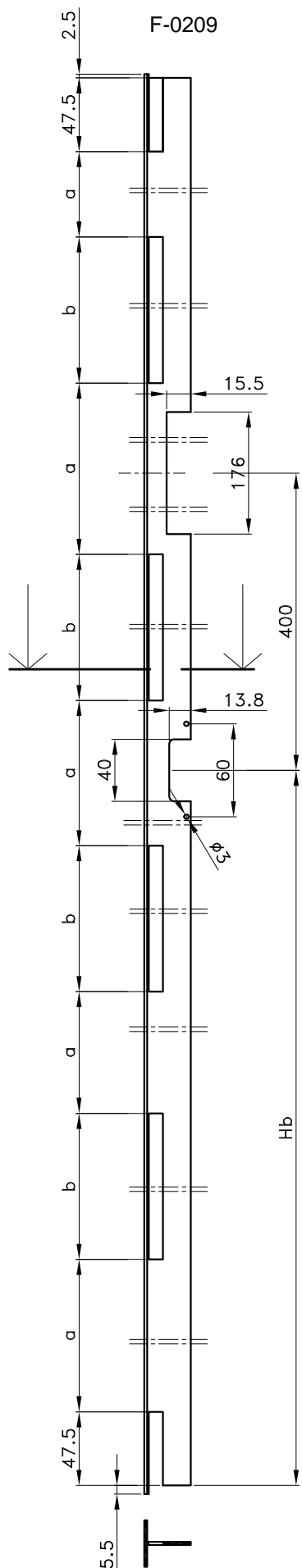

OBRADA PROFILA F-0209 I F-1011

- Za dvokrilna vrata - pomoćno krilo
- Obradjeni profili ulaze jedan u drugi po sistemu "češalj"

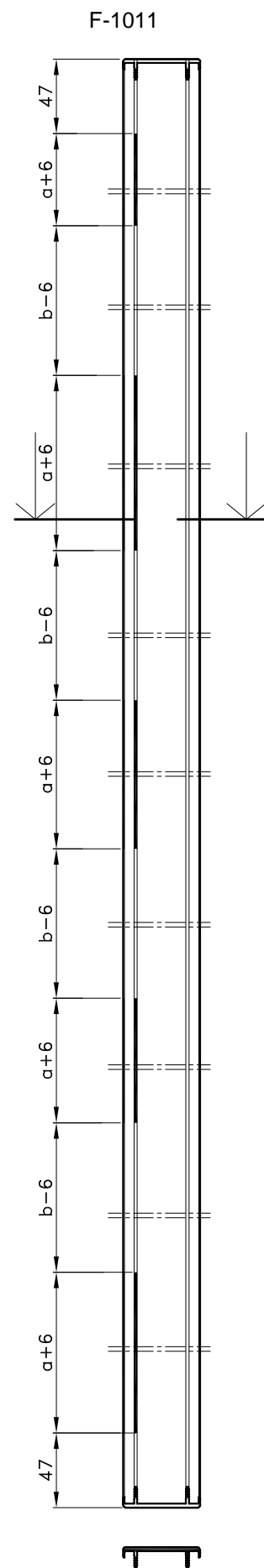
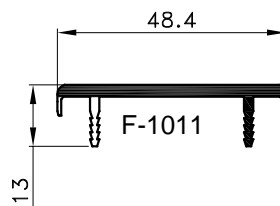
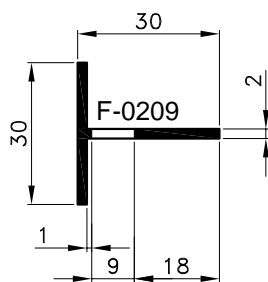
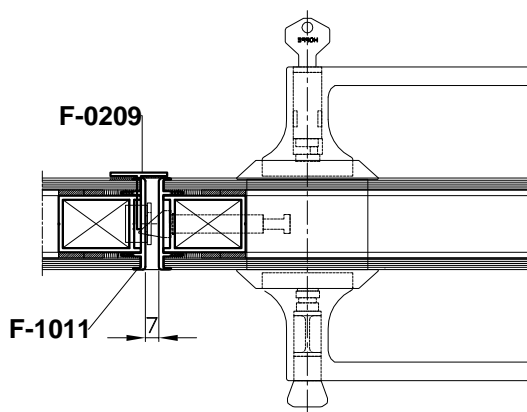

REZNE LISTE

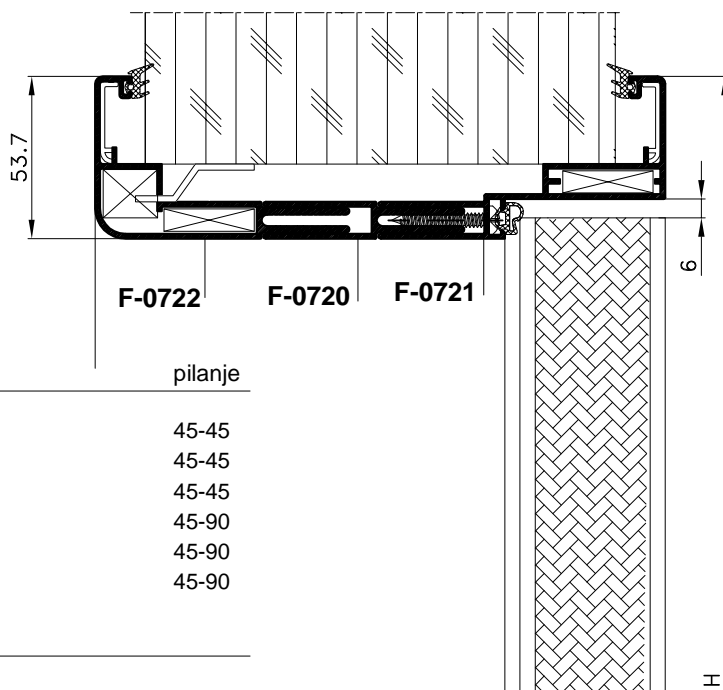
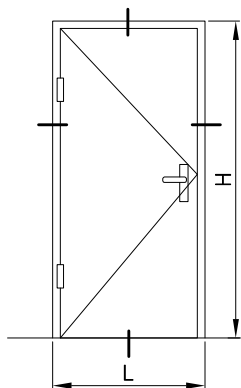

PROFILI		kom	mjera	pilanje
F-0722	vodoravnica dovratnika	1	L	45-45
F-0720	vodoravnica dovratnika	1	L-83	45-45
F-0721	vodoravnica dovratnika	1	L	45-45
F-0722	okomica dovratnika	2	H	45-90
F-0720	okomica dovratnika	2	H-41.5	45-90
F-0721	okomica dovratnika	2	H	45-90
OKOVI		kom		
710.102	kutnik na dovratniku	4		
710.105	kutnik na dovratniku	4		
730.010	pomoćni kutnik	4		
521.109	spojni lim	6		
111.012.xx	dvodjelna baglama	2		
PZ-88	brava za drvena vrata	1		
433.046	vijak 4.8x32-inox	svakih 300 mm		
BRTVE		kom	mjera	
314.004	brtva prema krilu vrata		L+2H	
321.003	brtva prema zidu		2L+4H	

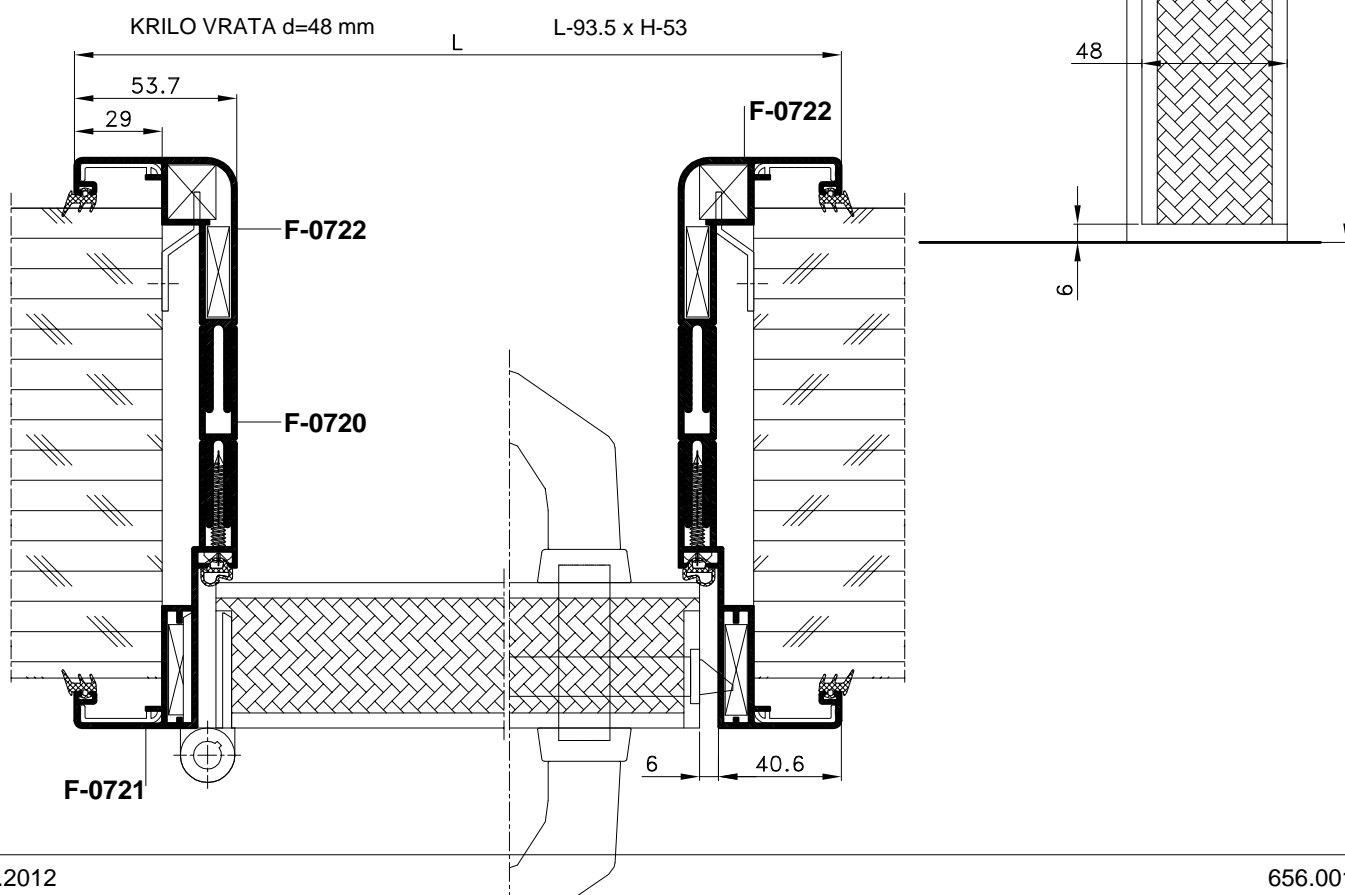

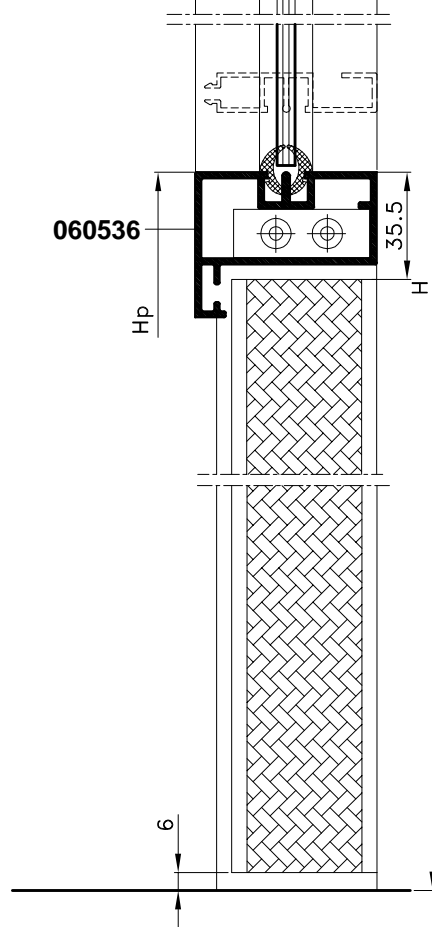
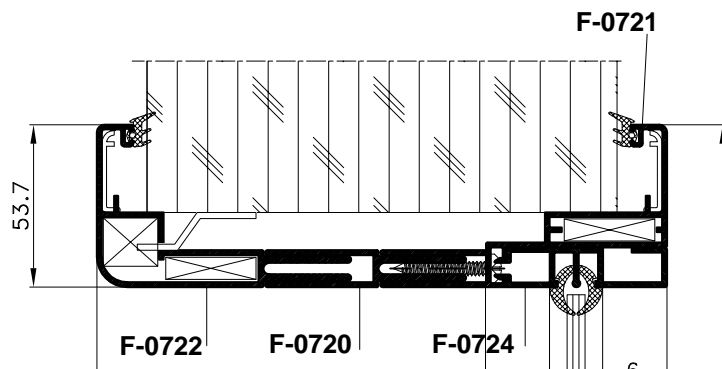
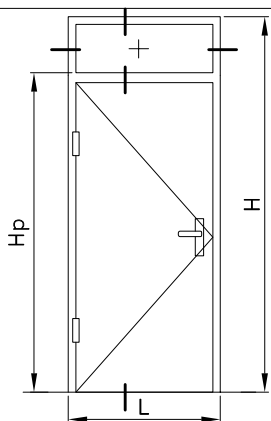

PROFILI		kom	mjera	pilanje
F-0722	vodoravnica dovratnika	1	L	45-45
F-0720	vodoravnica dovratnika	1	L-83	45-45
F-0721	vodoravnica dovratnika	1	L	45-45
F-0722	okomica dovratnika	2	H	45-90
F-0720	okomica dovratnika	2	H-41.5	45-90
F-0721	okomica dovratnika	2	H	45-90
060536	prečka	1	L-81	90-90
F-0724	vodoravna lajsna	1	L-81	90-90
F-0724	okomita lajsna	2	(H-Hp)-54	90-90

OKOVI		kom	
710.102	kutnik na dovratniku	4	
710.105	kutnik na dovratniku	4	
730.010	pomoćni kutnik	4	
521.109	spojni lim	6	
111.102.xx	dvodjelna baglama	2	
PZ-88	brava za drvena vrata	1	
433.046	vijak 4.8x32-inox	svakih 300 mm	
370.014	veznik prečke	2	

BRTVE		kom	mjera
314.004	brtva prema krilu vrata		L+2Hp
321.003	brtva prema zidu		2L+4H
314.005	brtva prema staklu		2L+2(H-Hp)
	KRILO VRATA d=48 mm		L-93.5 x Hp-41.5
	STAKLO d=6 mm		L-113 x (H-Hp)-60

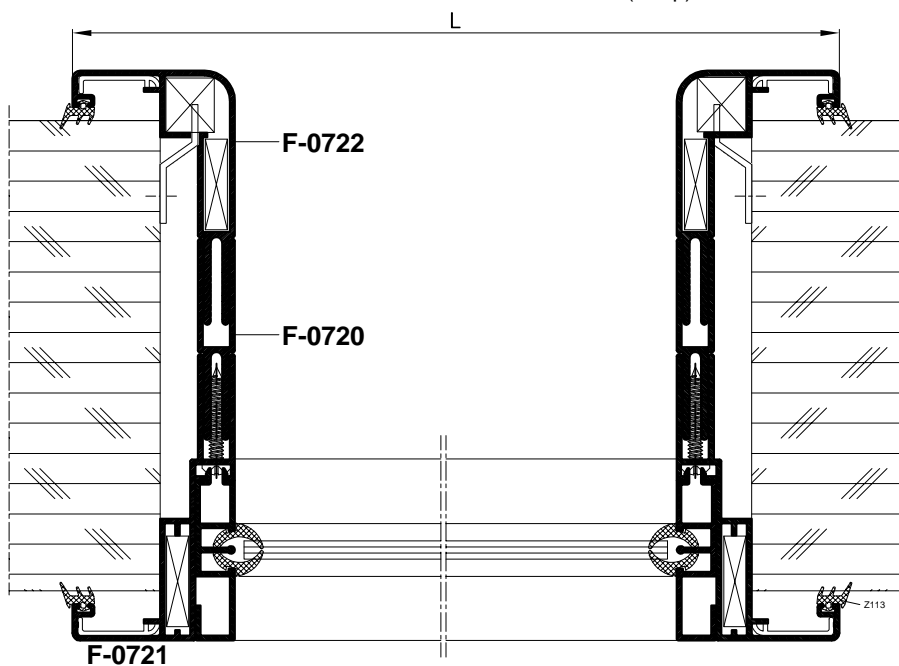

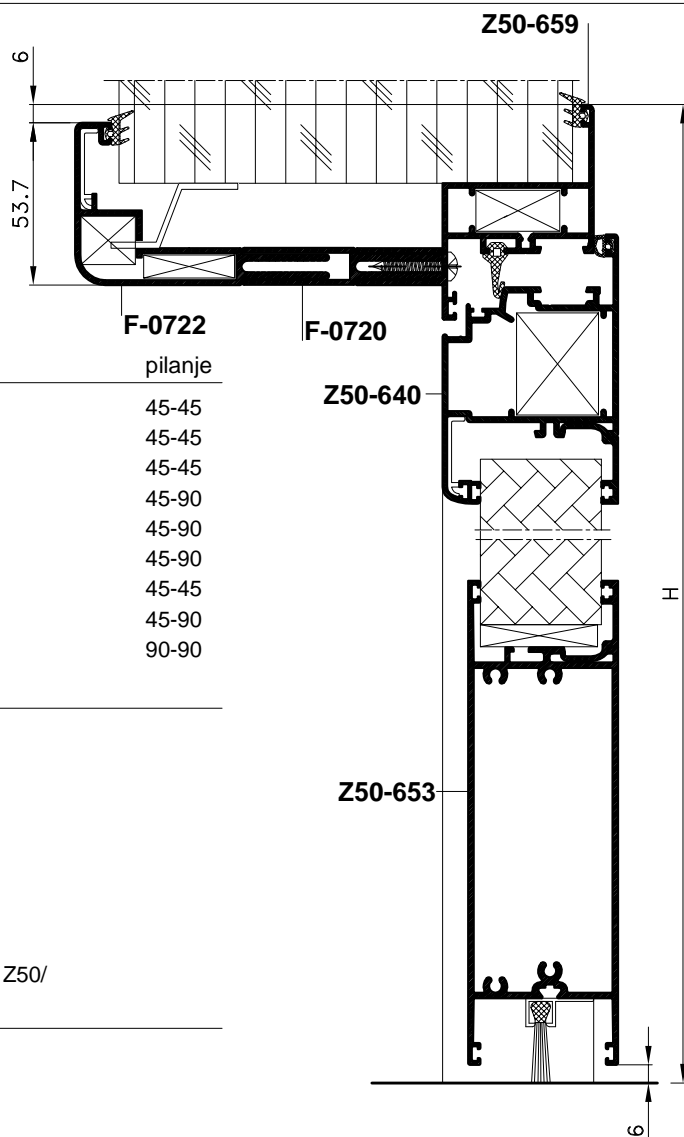
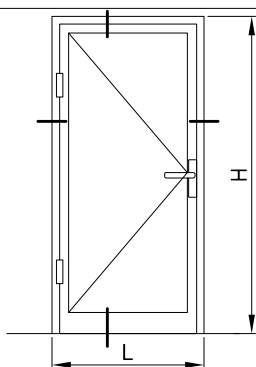
PROFILI

		kom	mjera	pilanje
F-0722	vodoravnica dovratnika	1	L-12	45-45
F-0720	vodoravnica dovratnika	1	L-95	45-45
Z50-659	vodoravnica dovratnika	1	L	45-45
F-0722	okomica dovratnika	2	H-6	45-90
F-0720	okomica dovratnika	2	H-47.5	45-90
Z50-659	okomica dovratnika	2	H	45-90
Z50-640	vodoravnica vrata	1	Lkr=L-86	45-45
Z50-640	okomica vrata	2	Hkr=H-49	45-90
Z50-653	parapet vrata	1	Lkr-124	90-90

OKOVI

		kom
710.102	kutnik na dovratniku-vani	2
710.105	kutnik na dovratniku-vani	2
730.008	kutnik na dovratniku-unutra	2
730.009	kutnik krila vrata	2
730.010	pomoćni kutnik	6
730.002	pomoćni kutnik	6
433.045	vijak 4.8x25-inox	svakih 300 mm
114.001.xx	dvodjelna baglama	2
	brava, ručka, šild i cilindar za vrata -/prema katalogu Z50/	

BRTVE

		kom	mjera
321.003	brtva prema zidu		2L+4H
331.001	središnja brtva vrata		L+H
321.001	brtva u krilu vrata		L+H
521.001	četkasta brtva u krilu		L
347.001	četkasta brtva u krilu		L

ISPUNA

		kom	mjera
	ispuna krila vrata	1	Lkr-148 xHkr-219

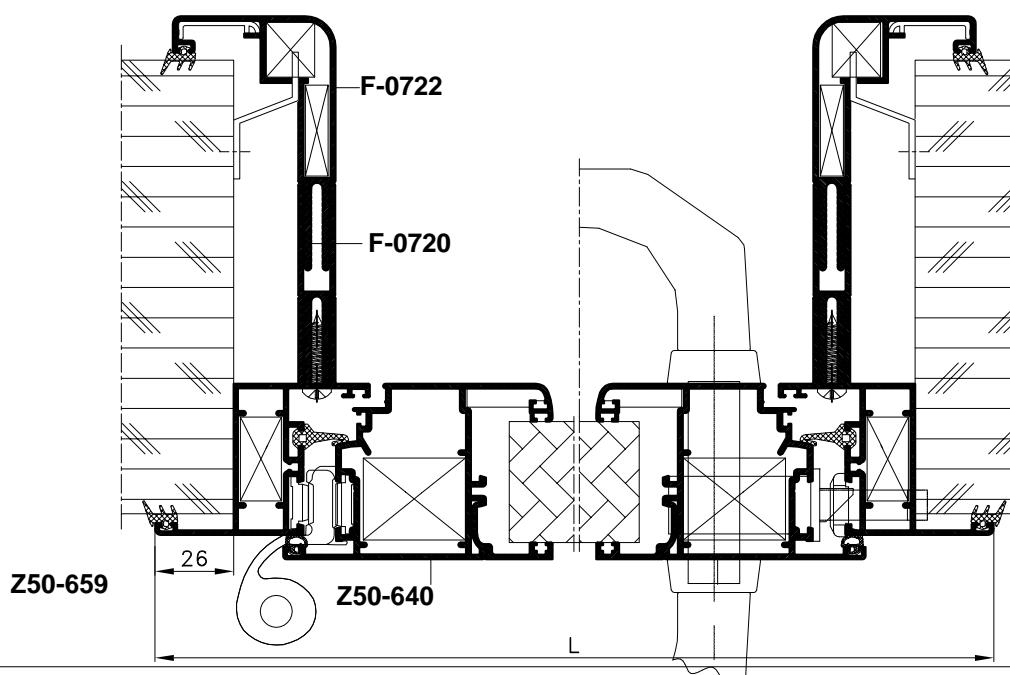

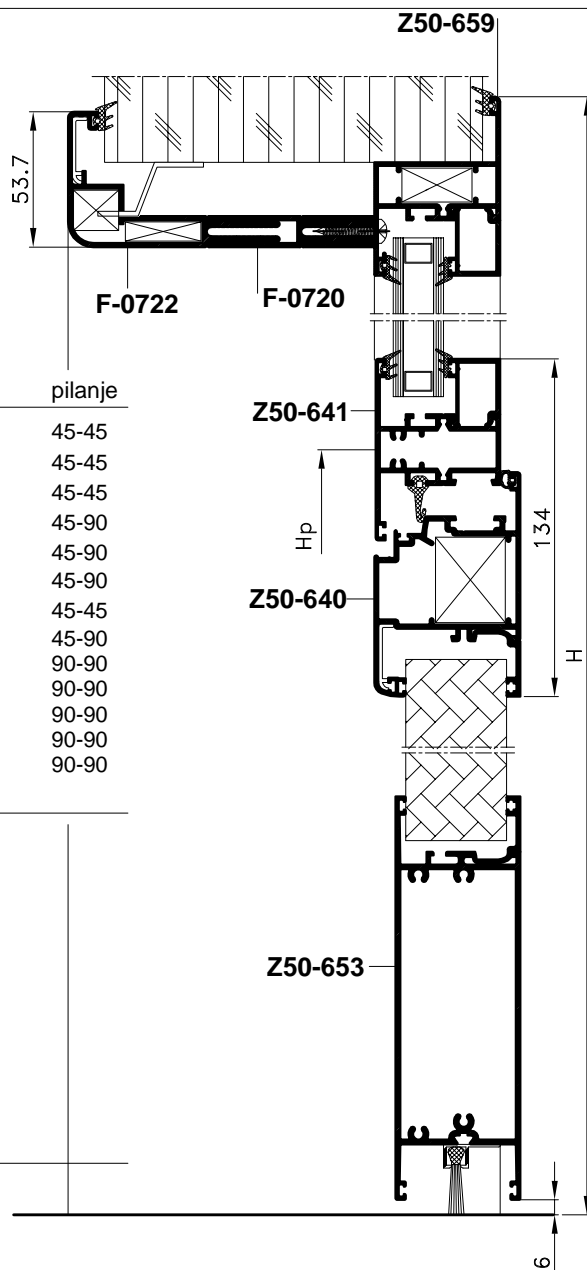
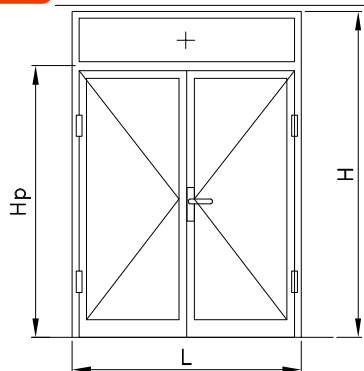

PROFILI		kom	mjera	planje
F-0722	vodoravnica dovratnika	1	L-12	45-45
F-0720	vodoravnica dovratnika	1	L-95	45-45
Z50-659	vodoravnica dovratnika	1	L	45-45
F-0722	okomica dovratnika	2	H-6	45-90
F-0720	okomica dovratnika	2	H-47.5	45-90
Z50-659	okomica dovratnika	2	H	45-90
Z50-640	vodoravnica vrata	2	Lkr=L/2-45.5	45-45
Z50-640	okomica vrata	4	Hkr=Hp-15	45-90
Z50-653	parapet vrata	2	Lkr-124	90-90
Z50-654	kombatuta	1	Hkr-34	90-90
Z50-641	prečka	1	L-88	90-90
Z40-644	vodoravna lajsna-fiksno	2	L-98	90-90
Z40-644	okomita lajsna-fiksno	2	(H-Hp)-107	90-90
OKOVI		kom		
710.102	kutnik na dovratniku-vani	2		
710.105	kutnik na dovratniku-vani	2		
730.008	kutnik na dovratniku-unutra	2		
730.009	kutnik krila vrata	4		
710.066	veznik prečke	10		
730.010	pomoćni kutnik	10		
730.002	pomoćni kutnik	10		
521.109	spojni lim	6		
433.046	vijak 4.8x25-inox		svakih 300 mm	
114.01.xx	dvodjelna baglama	2		
	brava, ručka, šild i cilindar za vrata -/prema katalogu Z50/			
BRTVE		kom	mjera	
321.003	brtva prema zidu		2L+4H	
331.001	središnja brtva vrata		L+3Hp	
321.001	brtva u krilu vrata		L+4Hp	
521.001	četkasta brtva u krilu		L	
347.001	četkasta brtva u krilu		L	
ISPUNA		kom	mjera	
	ispuna krila vrata	2	Lkr-148 xHkr-219	

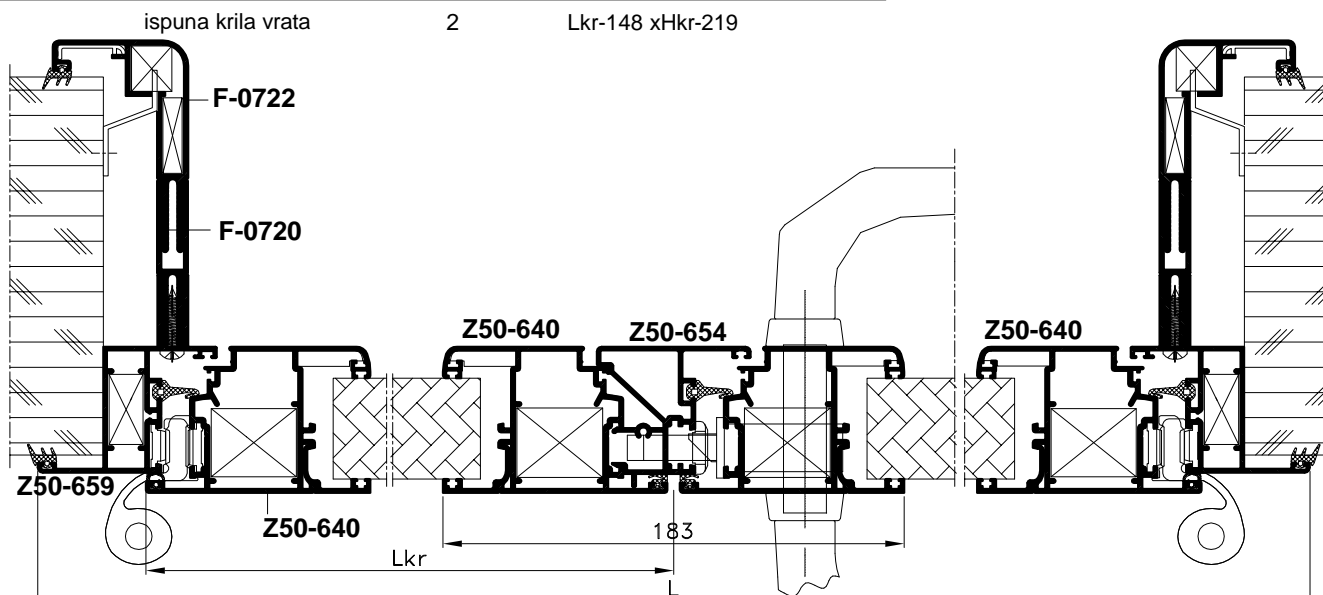

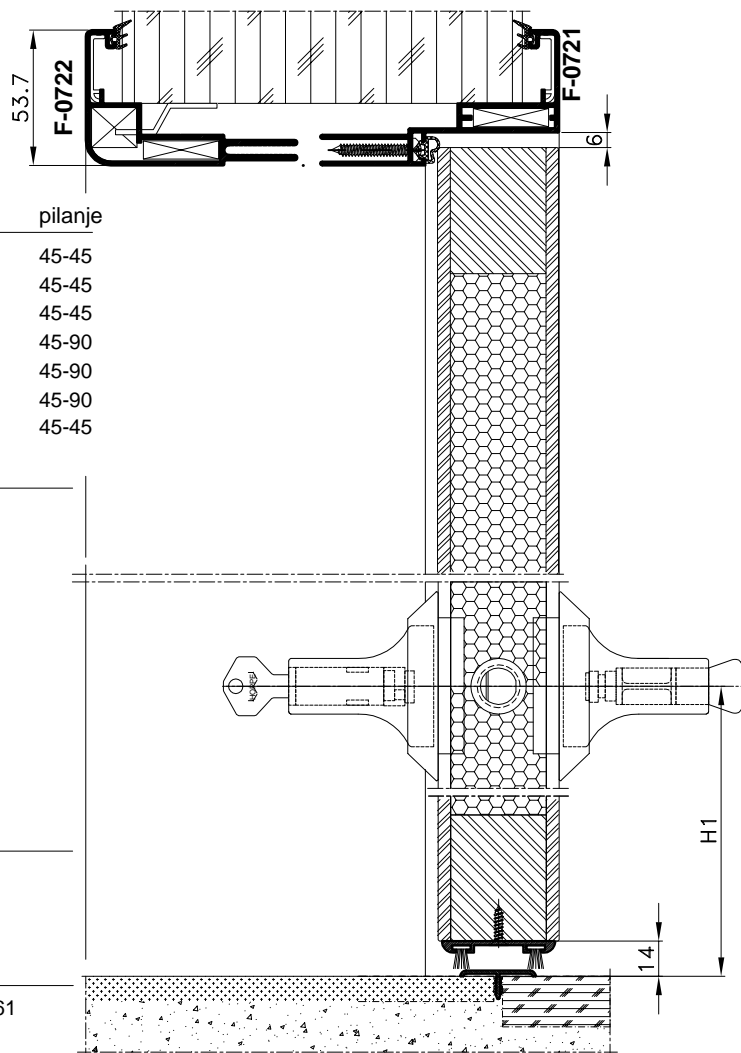
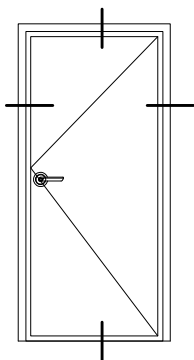

PROFILI		kom	mjera	pilanje
F-0722	vodoravnica dovratnika	1	L	45-45
F-0720	vodoravnica dovratnika	1	L-83	45-45
F-0721	vodoravnica dovratnika	1	L	45-45
F-0722	okomica dovratnika	2	H	45-90
F-0720	okomica dovratnika	2	H-41.5	45-90
F-0721	okomica dovratnika	2	H	45-90
P45 - 644	držač četkica	1	Lkr-3	45-45

OKOVI		kom	
710.102	kutnik na dovratniku	4	
710.105	kutnik na dovratniku	2	
730.002	pomoćni kutnik	4	
730.010	pomoćni kutnik	4	
521.109	spojni lim	6	
433.046	vijak 4.8 x 32-inox DIN 7981	svakih 300 mm	
433.105	vijak 3.9 x 16 inox DIN 7982	8	
110.002	K-6700 skrivena baglama	3	
120.000	Hoppe -HCS brava, ručka, šild sa podmetačem	1	

BRTVE		kom	mjera
321.003	brtva prema zidu		2L+4H
314.004	brtva prema krilu vrata		L+2H
340.011	četkica 7 x 9		Lkr+3 x 2

ISPUNA		kom	mjera
vrata	ispuna krila vrata	1	L-94 x H-61

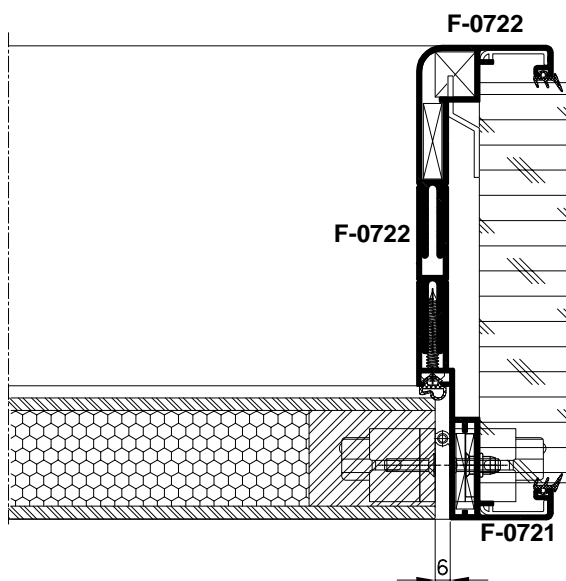
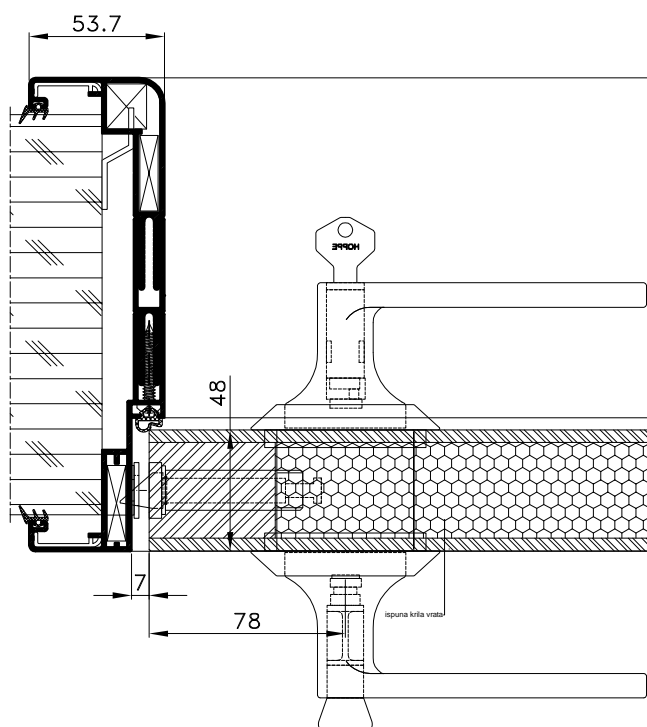

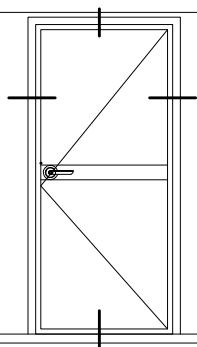

PROFILI		kom	mjera	pilanje
F-0722	vodoravnica dovratnika	1	L	45-45
F-0720	vodoravnica dovratnika	1	L-83	45-45
F-0721	vodoravnica dovratnika	1	L	45-45
F-0722	okomica dovratnika	2	H	45-90
F-0720	okomica dovratnika	2	H-41.5	45-90
F-0721	okomica dovratnika	2	H	45-90
F-1102	vodoravnica vrata	2	Lkr=L-99	45-45
F-1102	okomica vrata	2	Hkr=H-66	45-45
F-0201	prečka vrata	1	Lkr=87	90-90
F-1011	vodoravna lajsna vrata	2	Lkr+5	45-45
F-1011	okomita lajsna vrata	2	Hkr+5	45-45
P45 - 644	držač četkica	1	Lkr+3	90-90

OKOVI		kom	
710.102	kutnik na dovratniku	4	
710.105	kutnik na dovratniku	2	
730.002	kutnik na dovratniku	4	
730.010	pomoćni kutnik	4	
710.057	kutnik krila vrata	4	
710.106	spojnica prečke	1	
710.107	spojnica prečke	1	
521.105	podmetač za baglamu	6	
521.109	spojni lim	6	
433.046	vijak 4.8 x 32-inox DIN 7981	svakih 300 mm	
434.008	pop nitna Ø 4x8 aluminijska	4	
434.050	zakivna matica M5 x 13	6	
434.051	zakivna matica M5 x 16.5	6	
431.284	vijak M5 x 20 inox DIN 7991	12	
433.105	vijak 3.9 x 16 inox DIN 7982	8	
433.015	vijak 3.9 x 9.5 inox DIN 7981	24	
110.002	K-6700 skrivena baglama	3	
120.000	Hoppe -HCS brava, ručka , šild sa podmetačem	1	

BRTVE		kom	mjera
321.001	brtva prema zidu		2L+4H
314.004	brtva prema krilu vrata		L+2H
340.011	četkica 7 x 9		(Lkr+3) x 2

ISPUNA		kom	mjera
staklo	ispuna krila vrata	1L+D	Lkr-1 x Hkr-1

