

FEAL

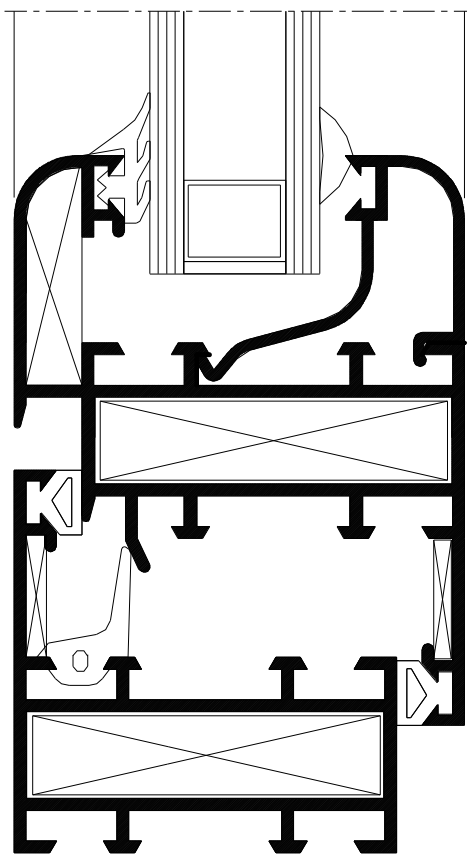

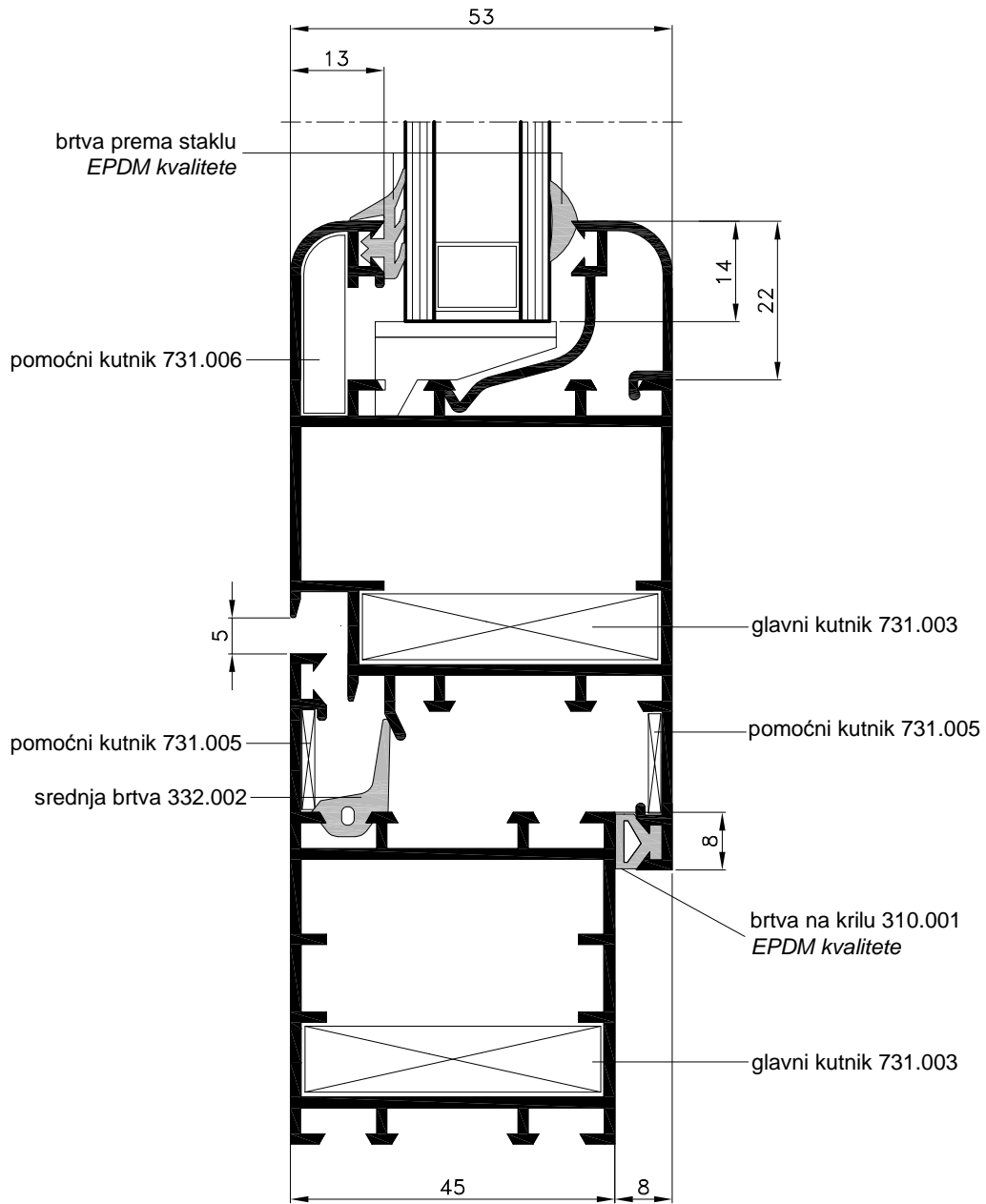



FEAL-poduzeće za preradu aluminija-Široki Brijeg Trn b.b.

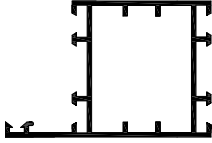
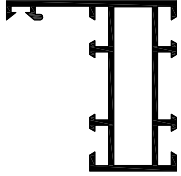
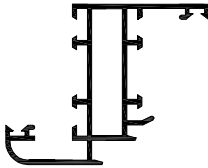
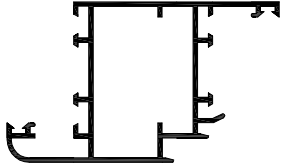
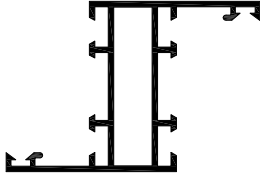
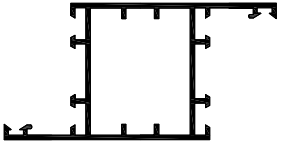
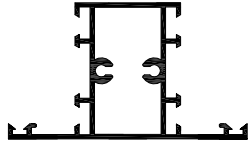
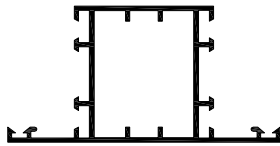
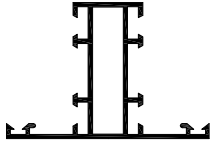

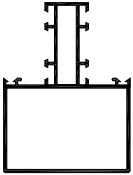

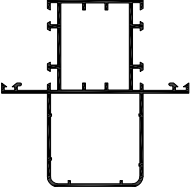
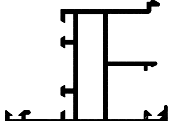







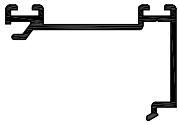

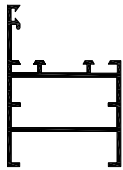

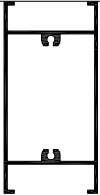

serija **45 DALMO**





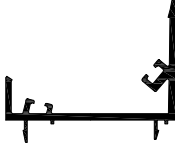
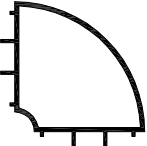



Oznaka	Izgled-presjek	Težina kg/ml	Opseg mm	Ix cm ⁴	Wx cm ³
D45-001		1.028	349		
D45-002		0.772	307		
D45-011		1.014	436		
D45-012		1.271	477		
D45-013		0.886	372		
F-0616		1.134	412		
D45-021		1.027	392		
D45-022		1.148	418		
D45-023		0.886	372		

Oznaka	Izgled-presjek	Težina kg/ml	Opseg mm	Ix cm ⁴	Wx cm ³
D45-024		1.642	461		
D45-025		1.953	554		
D45-026		2.001	545		
D45-027		1.687	861		
D45-030/A		0.937	510		
D45-040		0.285	167		
D45-041		0.307	180		
D45-042		0.295	173		
D45-043		0.304	187		

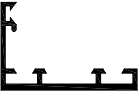
Oznaka	Izgled-presjek	Težina kg/ml	Opseg mm	Ix cm ⁴	Wx cm ³
D45-050		0.588	285		
D45-053		0.169	98		
D45-054		0.386	213		
D45-055		0.113	53		
D45-070		0.903	333		
D45-071		0.229	133		
D45-072		1.295	357		
D45-074		0.570	195		
D45-075		0.451	215		

Oznaka	Izgled-presjek	Težina kg/ml	Opseg mm	Ix cm ⁴	Wx cm ³
D45-076		0.307	164		
P45-631		0.482	176		
P45-641		0.326	151		
M45-752		0.510	242		
M45-754		0.932	248		
060 353		0.825	225		
060 350		0.285	107		
F-0228		0.153	68		
Z40-657		0.186	73		

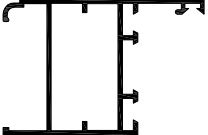
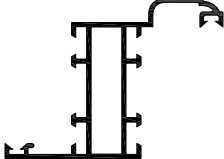
Oznaka	Izgled-presjek	Težina kg/ml	Opseg mm	Ix cm ⁴	Wx cm ³
F-0681		0.920	304		
F-0714		0.895	294		
D45-057		0.475	222		
D45-045		0.293	180		
D45-052		0.567	283		
D45-077		0.343	212		
D45-079		1.202	327		
D45-078		0.915	338		
D45-080		0.948	405		

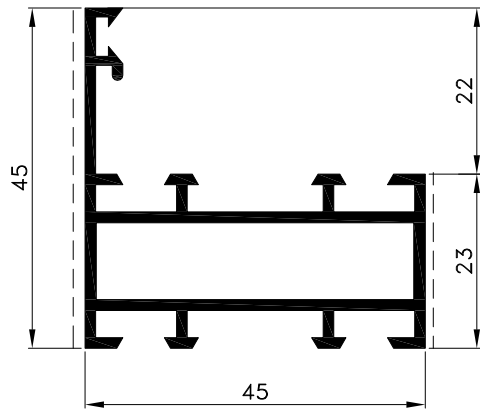

D45-002

težina: kg/ml 0.772
svj.povr. mm 68

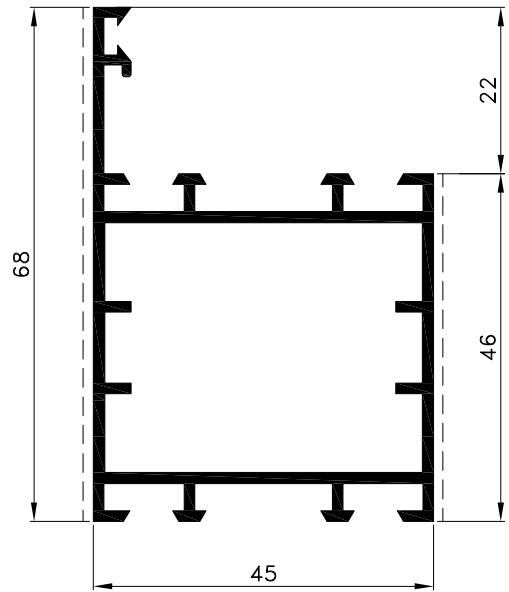

D45-001

težina: kg/ml 1.028
svj.povr. mm 114

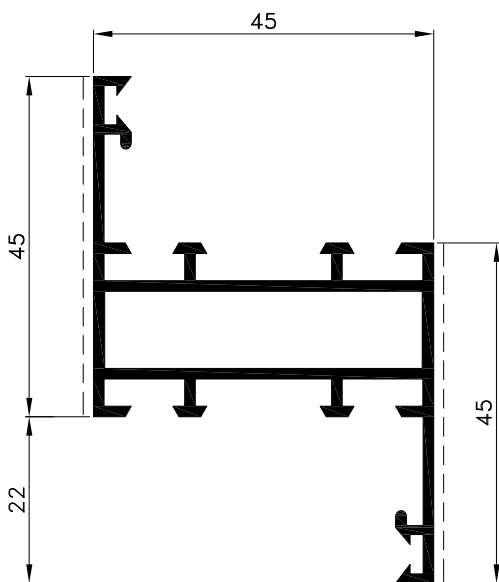

D45-013

težina: kg/ml 0.886
svj.povr. mm 90

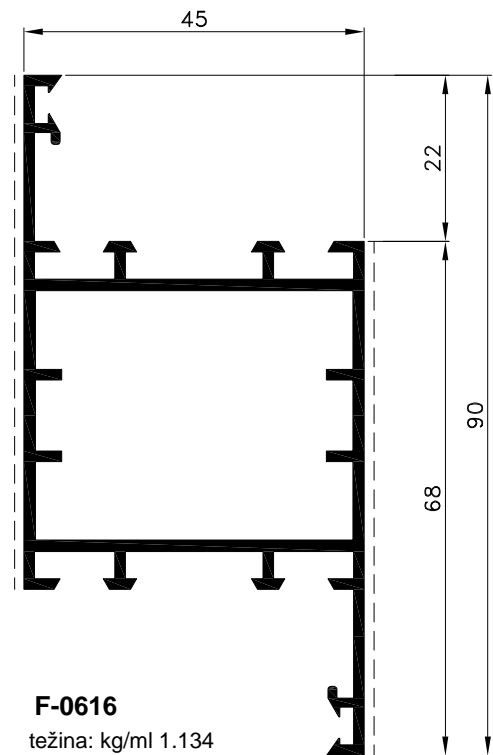

F-0616

težina: kg/ml 1.134
svj.povr. mm 136

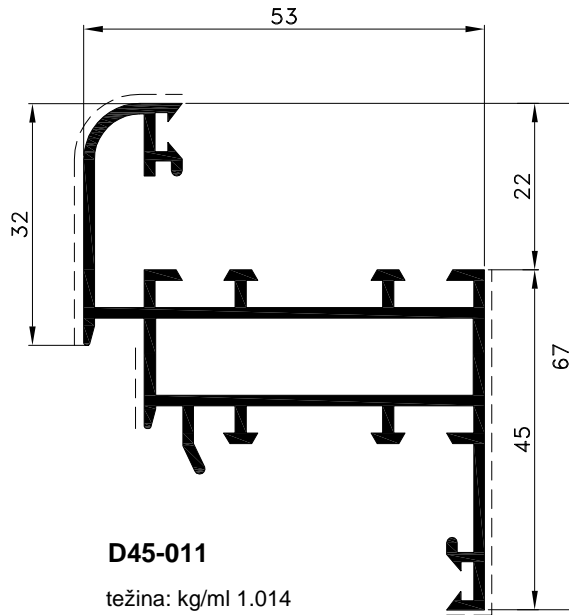

D45-011

težina: kg/ml 1.014
svj.povr. mm 104

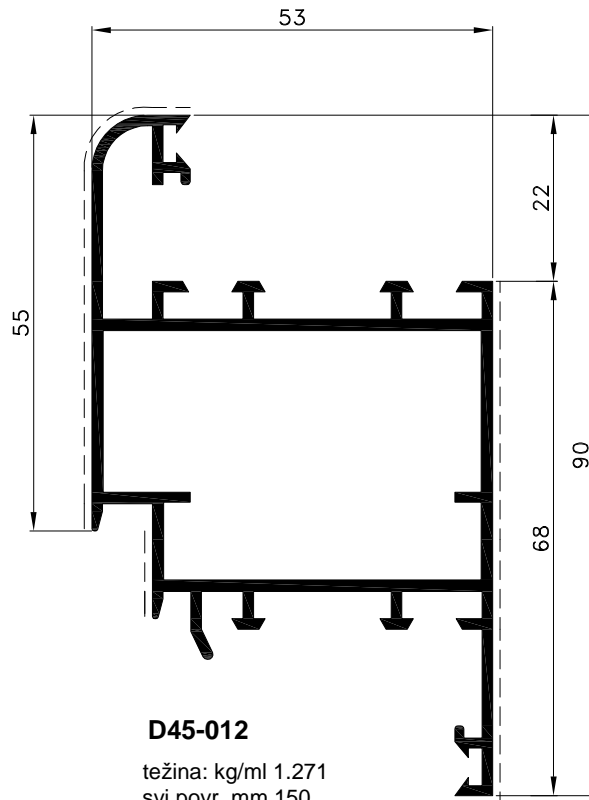

D45-012

težina: kg/ml 1.271
svj.povr. mm 150

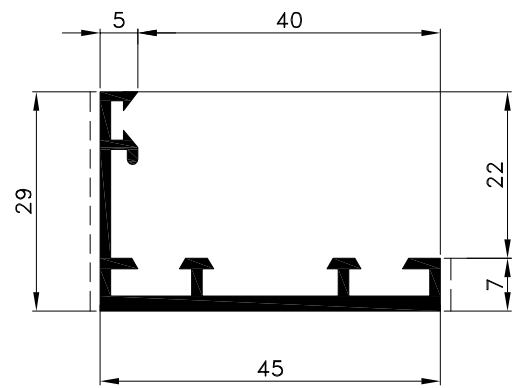
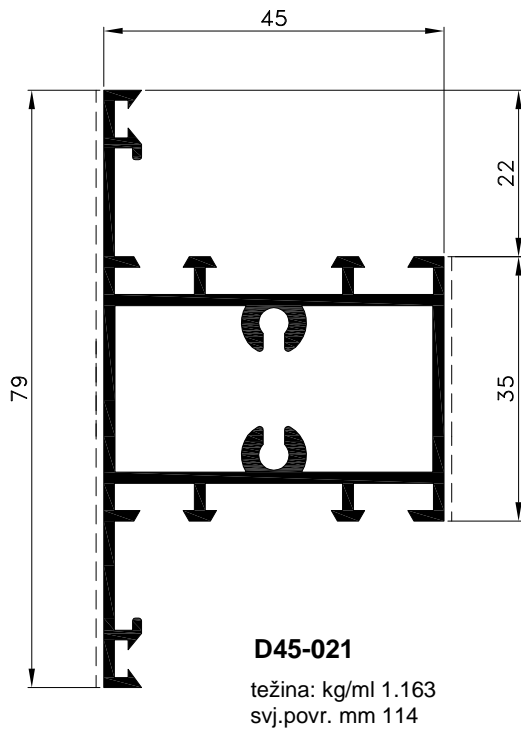
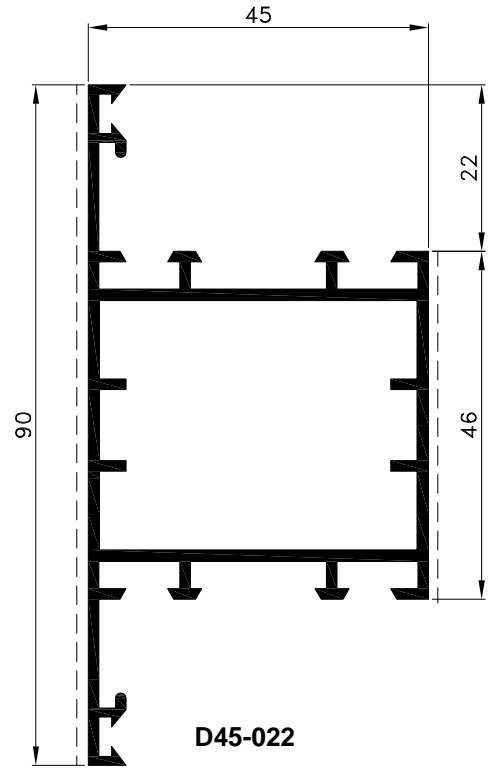
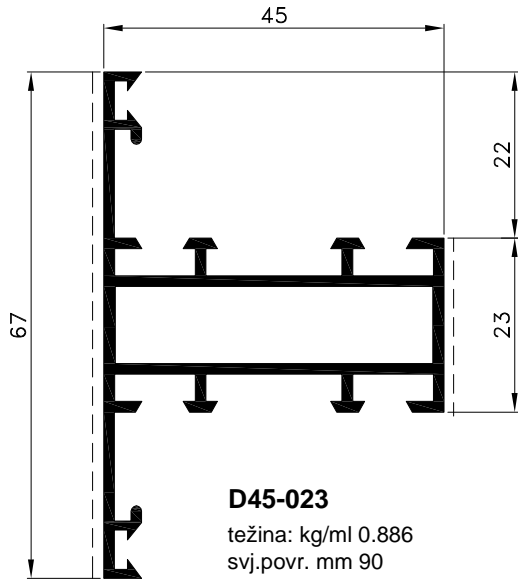

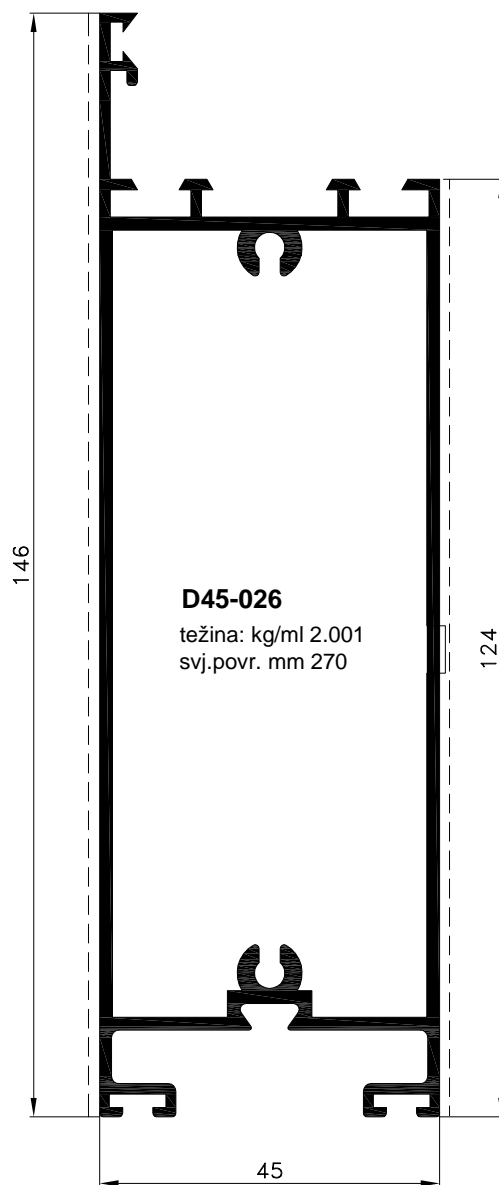
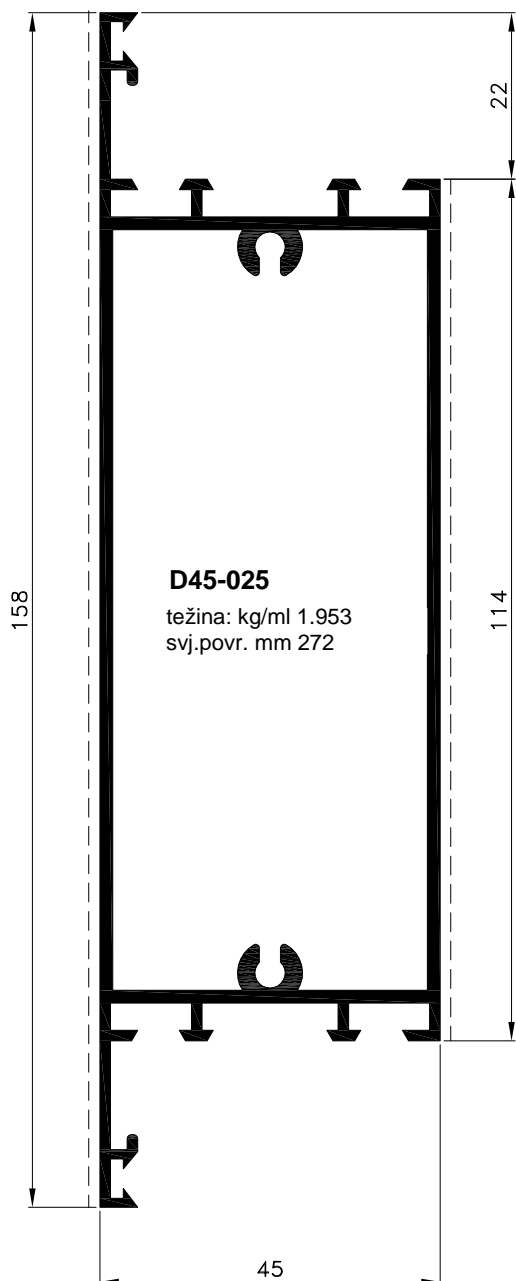

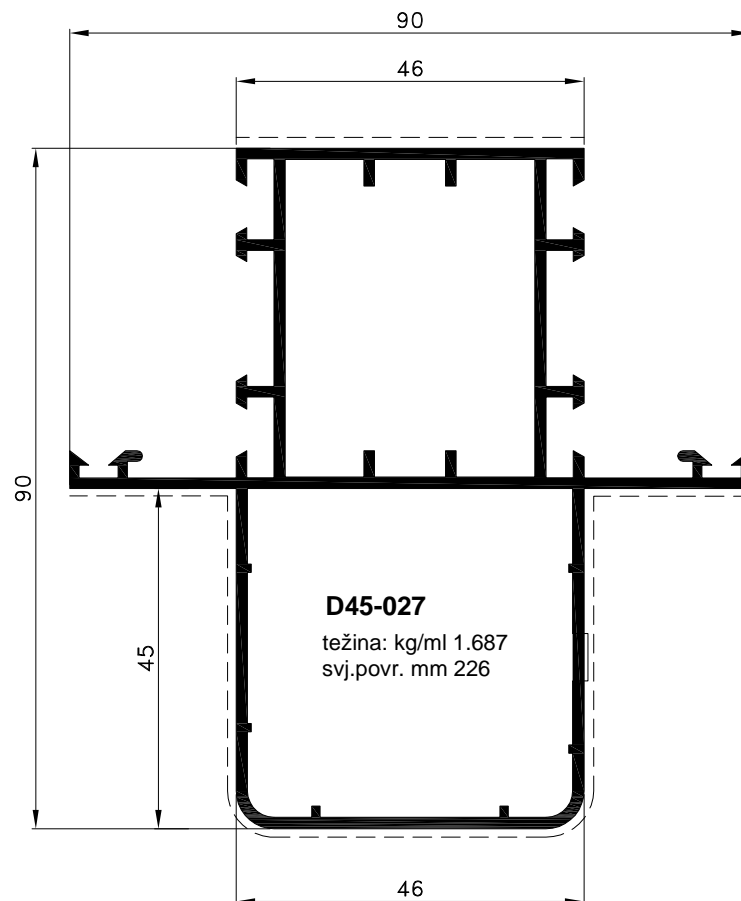
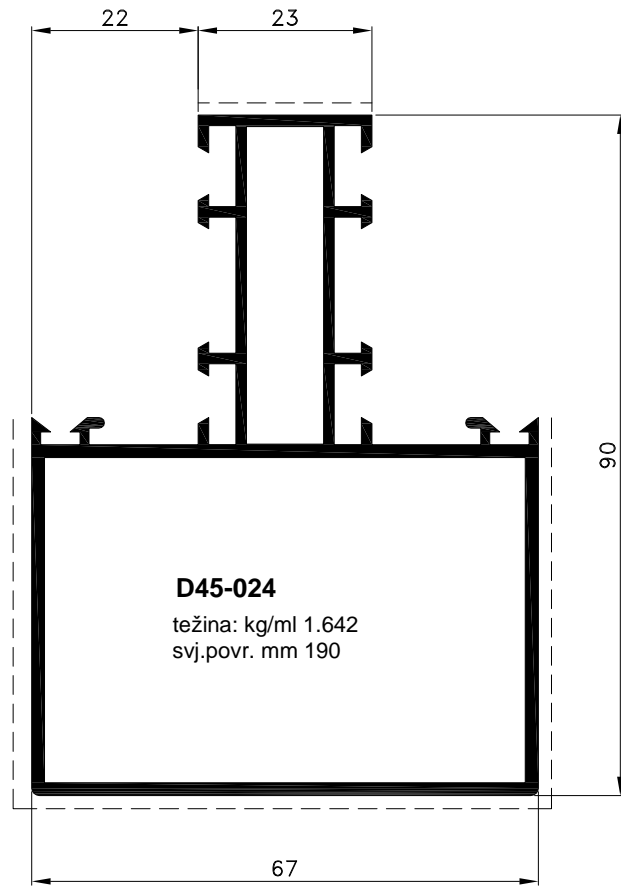

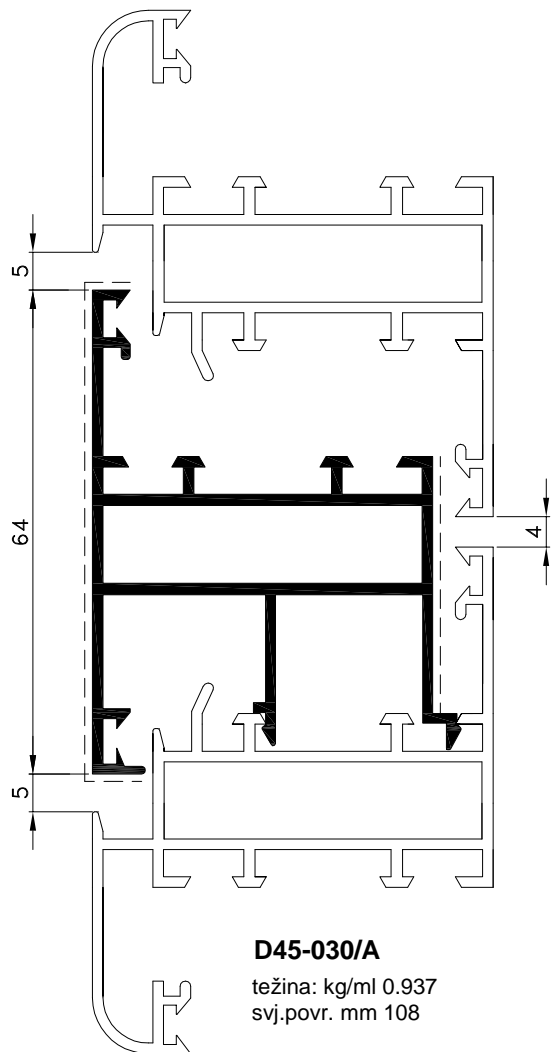

D45-030/A
težina: kg/ml 0.937
svj.povr. mm 108

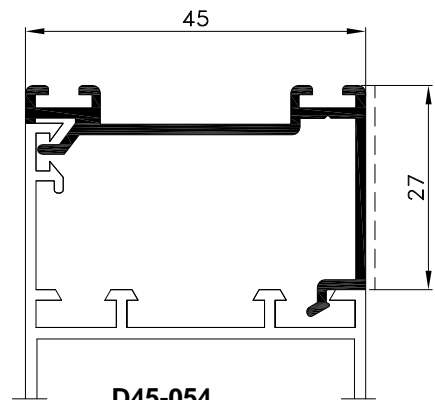

D45-054
težina: kg/ml 0.386
svj.povr. mm 32

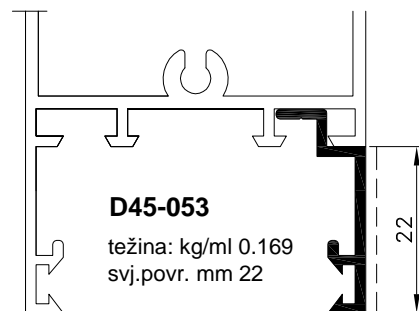

D45-053
težina: kg/ml 0.169
svj.povr. mm 22

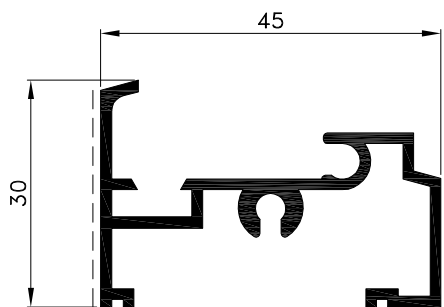

D45-050
težina: kg/ml 0.588
svj.povr. mm 46

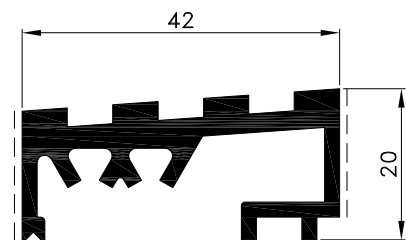

060 353
težina: kg/ml 0.825
svj.povr. mm 34

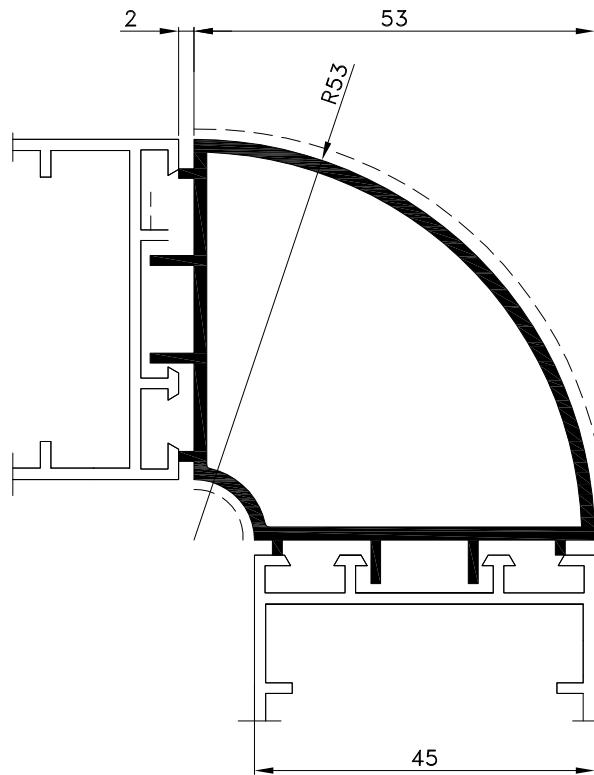

M45-754

težina: kg/ml 0.932
svj.povr. mm 95

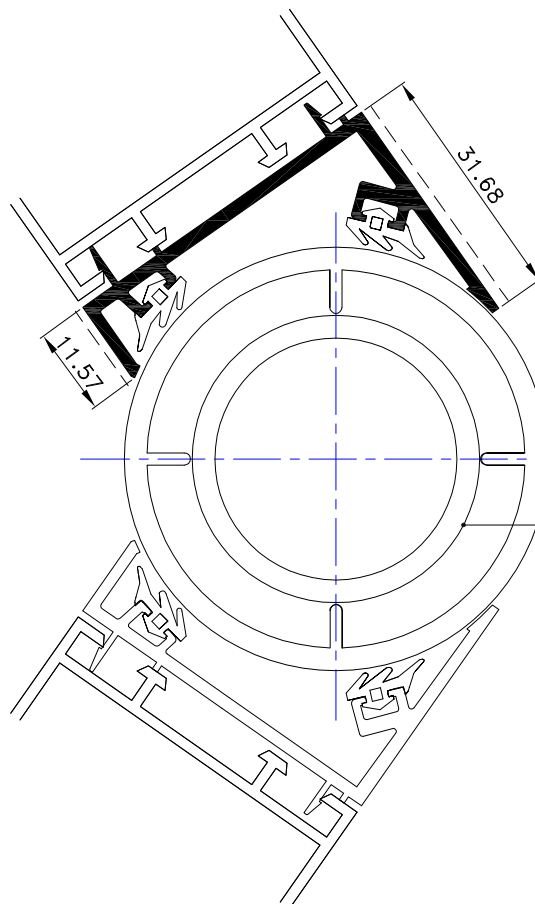

M45-752

težina: kg/ml 0.510
svj.povr. mm 43

F-0352/A

težina: kg/ml 1.445

HS-38

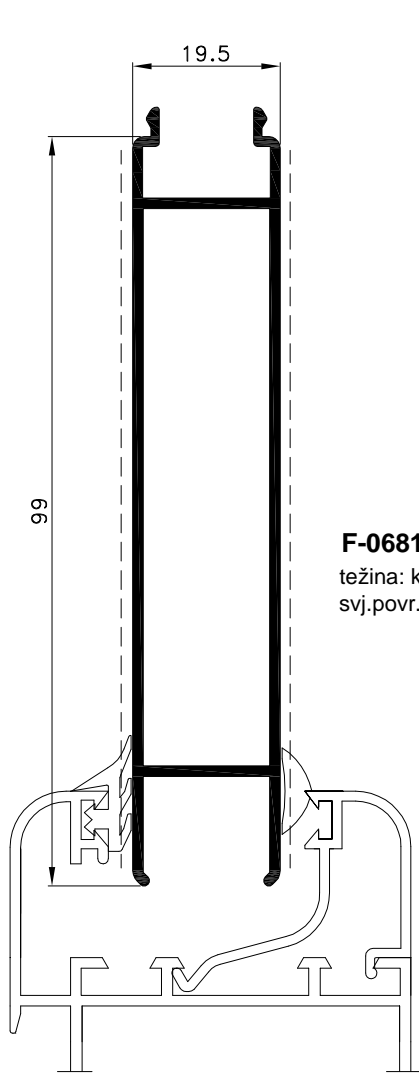

F-0681
težina: kg/ml 0.920
svj.povr. mm 195

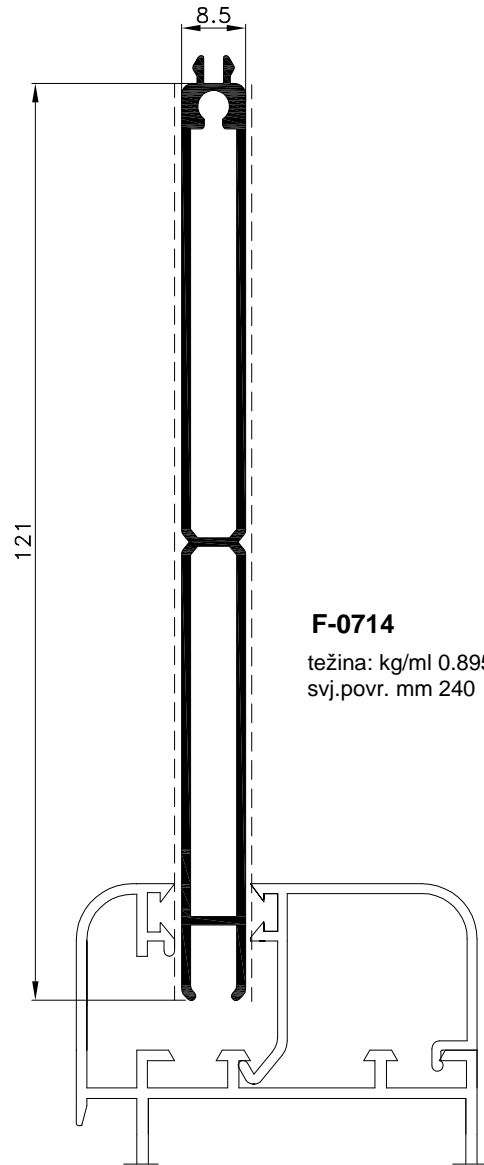

F-0714
težina: kg/ml 0.895
svj.povr. mm 240

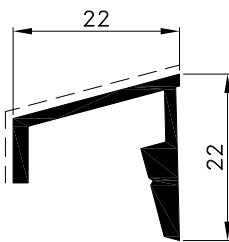

060 350
težina: kg/ml 0.285
svj.povr. mm 31

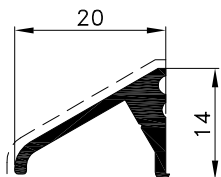

Z40-657
težina: kg/ml 0.186
svj.povr. mm 23

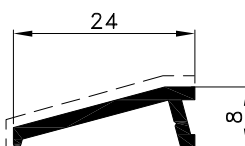

F-0228
težina: kg/ml 0.153
svj.povr. mm 27

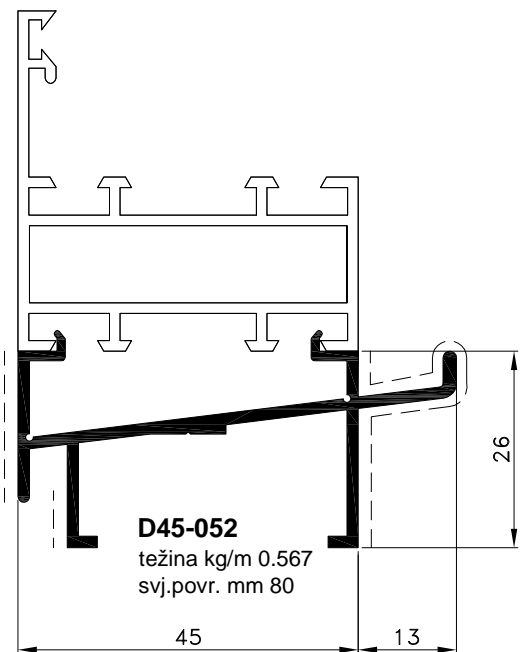

D45-052
težina kg/m 0.567
svj.povr. mm 80

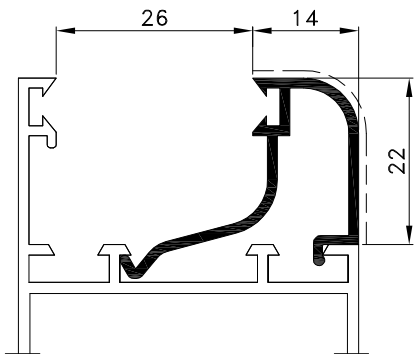

D45-040
težina: kg/ml 0.285
svj.povr. mm 34

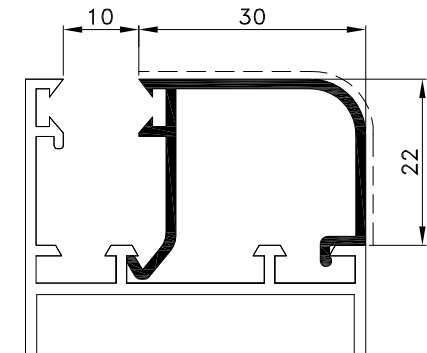

D45-041
težina: kg/ml 0.307
svj.povr. mm 50

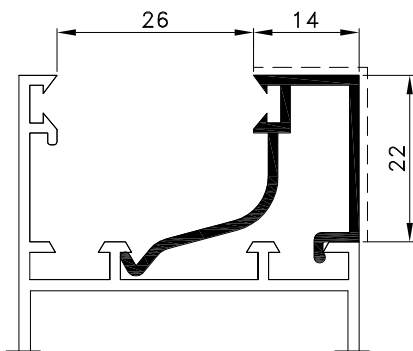

D45-042
težina: kg/ml 0.295
svj.povr. mm 36

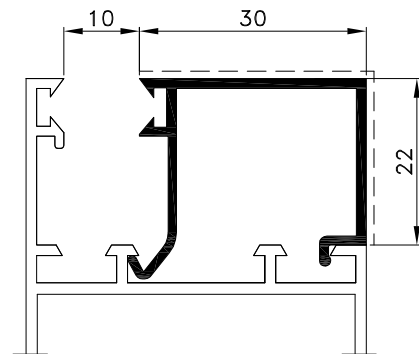

D45-043
težina: kg/ml 0.304
svj.povr. mm 52

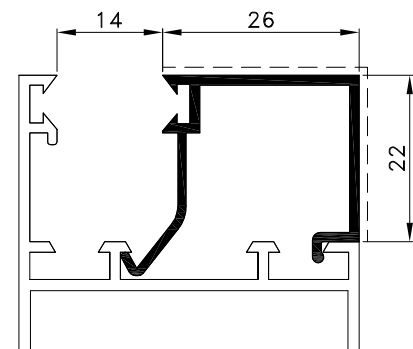





D45-045
težina: kg/ml 0.293
svj.povr. mm 48





CODE	Izgled-presjek	Opis	Materijal	Nap.
115.001.01 02 03		- Dvodijelna šarka - Stara oznaka D-100 (0128 xxx) - Boje: 01- bijela; 02 - siva;03 - crna		
110.005.01 02 03		- Dvodijelna šarka - Stara oznaka D-100 (A 9616 xxx) - Boje: 01- bijela; 02 - siva;03 - crna		
111.010.01 02 03		- Dvodijelna šarka - Stara oznaka D-100 - Boje: 01- bijela; 02 - siva;03 - crna		
111.011.01 02 03		- Trodijelna šarka-češalj - Stara oznaka D-120 - Boje: 01- bijela; 02 - siva;03 - crna		
115.002.01 02 03		- Trodijelna šarka-češalj - Stara oznaka D-120 (0602 xxx) - Boje: 01- bijela; 02 - siva;03 - crna		
110.006.01 02 03		- Šarka za treće krilo - Stara oznaka 501.240.xx (A9626 R xxxx) - Boje: 01- bijela; 02 - siva;03 - crna		
115.003.01 02 03		- Šarka za treće krilo - Stara oznaka 501.240.xx (0143 xxx) - Boje: 01- bijela; 02 - siva;03 - crna		
115.004.01 02 03		- Šarka za vrata - Stara oznaka 280.015.xx (0592 xxx) - Boje: 01- bijela; 02 - siva;03 - crna		
113.009.01 02 03		- Šarka za vrata - Stara oznaka 280.015.xx (Max 3D68 xxxx) - Boje: 01- bijela; 02 - siva;03 - crna		
731.003		- Kutna spojnica - Stara oznaka: 0432		
731.004		- Kutna spojnica - Stara oznaka: 0432 (AO311)		



CODE	Izgled-presjek	Opis	Materijal	Nap.
731.005		- Pomoćna kutna spojnica - Stara oznaka 502.123.55 (A2181)	PVC	
731.006		- Pomoćna kutna spojnica - Stara oznaka 502.143.45 (P.K široki)	PVC	
710.101		- Veznik - Stara oznaka D-200	Al.	
143.014		- Vezni element ručke za unutra - Stara oznaka 404.110.55 (02385)		
143.015		- Vezni element ručke za vani-grilja - Stara oznaka 404.130.01 (02250)		
143.016		- Vezni element ručke za vani-grilja - Stara oznaka 404.130.01 (02377)		
105.002.01 02 03		- Dvostrana ručka za unutarnje otvaranje - Stara oznaka 503.420.xx (1000 xxxx)		

CODE	Izgled-presjek	Opis	Materijal	Nap.
105.003.01 02 03		- Ručka za vrata - Stara oznaka 290.036.xxx (2462 xxxx) - Boje: 01- bijela; 02 - siva;03 - crna		
100.001.01 02 03		- Ručka za vrata - Stara oznaka 290.036.xxx (A3060 xxxx) - Boje: 01- bijela; 02 - siva;03 - crna		
100.002.01 02 03		- Ručka za vrata - Stara oznaka 290.036.xxx (RV-09-02 xxxx) - Boje: 01- bijela; 02 - siva;03 - crna		
143.017		- Fiksni zapinjač pomoćnog krila - Stara oznaka 403.801.55 (02131)		
143.018		- Zapinjač - Stara oznaka 404.120.55 (02141)		
143.019		- Pojedinačni nasuprotni zasun - Stara oznaka 504.081.55 (A4217)		
143.020		- Pojedinačni nasuprotni zasun - Stara oznaka 504.081.55 (01317)		
143.021		- Umetak za treće klučanje - Stara oznaka 504.103.01 (1343)		

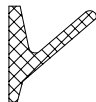
CODE	Izgled-presjek	Opis	Materijal	Nap.
360.001		- Čep za profil D45-030 - Stara oznaka 407.740.55 (A2110)		
360.002		- Čep za profil D45-030 - Stara oznaka 407.740.55 (02439)		
373.003		- Maska za drenažni otvor - Stara oznaka 509.261.55 (2428 xxxx)		
135.010		- Škare utklopnog prozora - Stara oznaka D-300 (02042-veća)		
135.011		- Škare utklopnog prozora - Stara oznaka D-300 (02043-manja)		
144.001		- Škljoca otklopnog prozora - Stara oznaka 503.640.xxxx (01706 xxxx)		

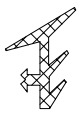
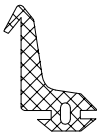
CODE	Izgled-presjek	Opis	Materijal	Nap.
135.001		<ul style="list-style-type: none"> - Bazni mehanizam za o-z - Stara oznaka 04766 		
135.002		<ul style="list-style-type: none"> - Šarke za o-z - Stara oznaka 04721 xxx 		
135.003		<ul style="list-style-type: none"> - Mala škara o-z za krilo od 390-540 mm širine - Stara oznaka 04229 		
135.004		<ul style="list-style-type: none"> - Velika škara za krilo od 540-1000 mm širine - Stara oznaka 04230 		
135.005		<ul style="list-style-type: none"> - Ručka za o-z - Stara oznaka 01094 xxx (1090 xxxx) 		
135.006		<ul style="list-style-type: none"> - Dodatne škarke za krila preko 1000 mm širine - Stara oznaka 04308 		
135.007		<ul style="list-style-type: none"> - Leđno ključanje za o-z - Stara oznaka 04648 		
135.008		<ul style="list-style-type: none"> - Kračuni za pomoćno krilo - Stara oznaka 04265 		
135.009		<ul style="list-style-type: none"> - Šarke za pomoćno krilo - Stara oznaka 04722 xxx 		

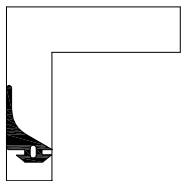
CODE	Izgled-presjek	Opis	Materijal	Nap.
311.011		- Brtva prema staklu-unutarnja. Nosi 2.5 mm. - Stara oznaka G114.2003 (210001125)	EPDM	
311.012		- Brtva prema staklu-unutarnja. Nosi 3/4 mm. - Stara oznaka G114.2004 (210001123)	EPDM	
312.001		- Brtva prema staklu-unutarnja. Nosi 1.5 mm. - Stara oznaka 126 091 (01005)	EPDM	
311.013		- Brtva prema staklu-unutarnja. Nosi 5 mm. - Stara oznaka 126 036 (210000059)	EPDM	
322.003		- Brtva prema staklu-vanjska. Nosi 3 mm. - Stara oznaka G114.2059 (02004)	EPDM	
320.001		- Brtva prema staklu-vanjska. Nosi 3 mm. - Stara oznaka G114.2059 (PR1015-2004)		
332.002		- Srednja brtva - Stara oznaka G114.1.042 (02763)	EPDM	
330.001		- Srednja brtva - Stara oznaka G114.1.042 (PR1010-2763)		

CODE	Izgled-presjek	Opis	Materijal	Nap.
310.001		- Brtva na spoju-unutarnja i vanjska. - Stara oznaka G114.2002 (PR1011-1866)	EPDM	
310.002		- Brtva na spoju-unutarnja i vanjska. - Stara oznaka G114.2002 (PR1012-3866)		
312.002		- Brtva na spoju-unutarnja i vanjska. - Stara oznaka G114.2002 (01866)		
312.003		- Brtva na spoju-unutarnja i vanjska. - Stara oznaka G114.2002 (03866)		
362.001		- Kutni umetak za centralnu brtvu - Stara oznaka 520.042.55 (04018)	EPDM	
340.011		Četkasta brtva 7x9 -Stara oznaka: Četkasta brtva 7x9	EPDM	
312.004		- Brtva na spoju-unutarnja i vanjska. - Stara oznaka 02405 - Brtva za utiskivanje	EPDM	

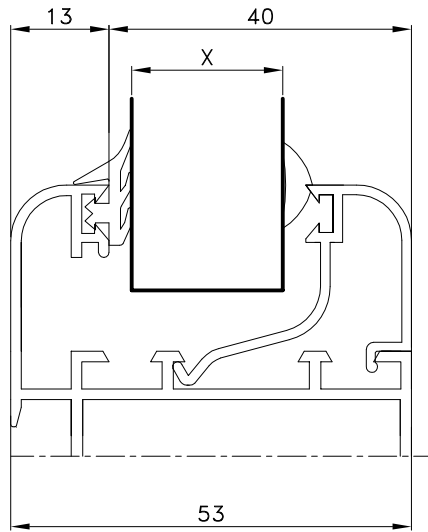

Ispuna X	Vanjska brtva	Unutarnja brtva	Lajsna	
3-4	322.003	311.012		
4-5	3200.003	311.011		
6	322.003	312.001		
7-8	322.003	311.012		
8-9	322.003	311.011		
10	322.003	312.001		
18	322.003	311.013		
19-20	322.003	311.012		
21	322.003	311.011		
22	322.003	312.001		

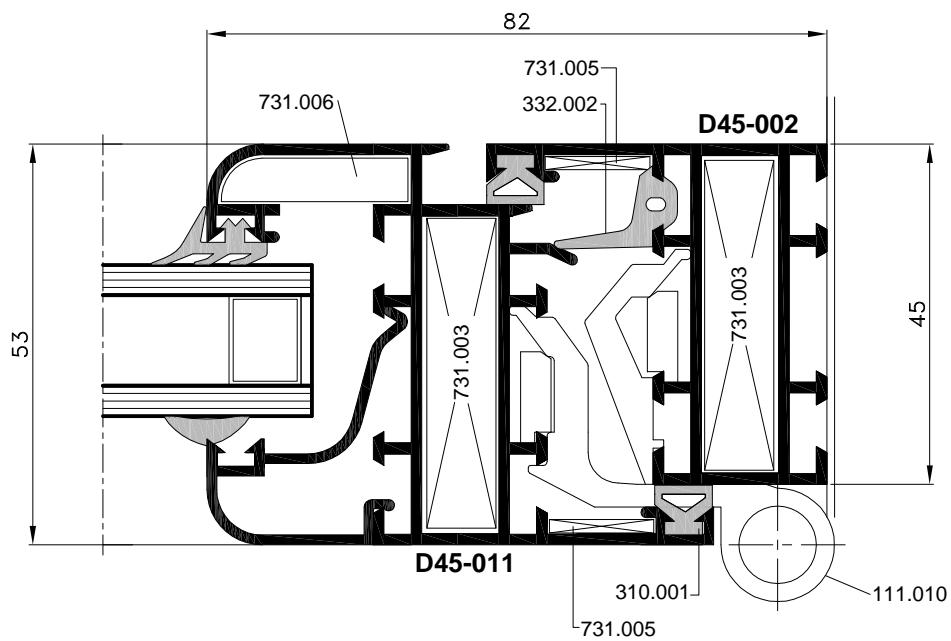
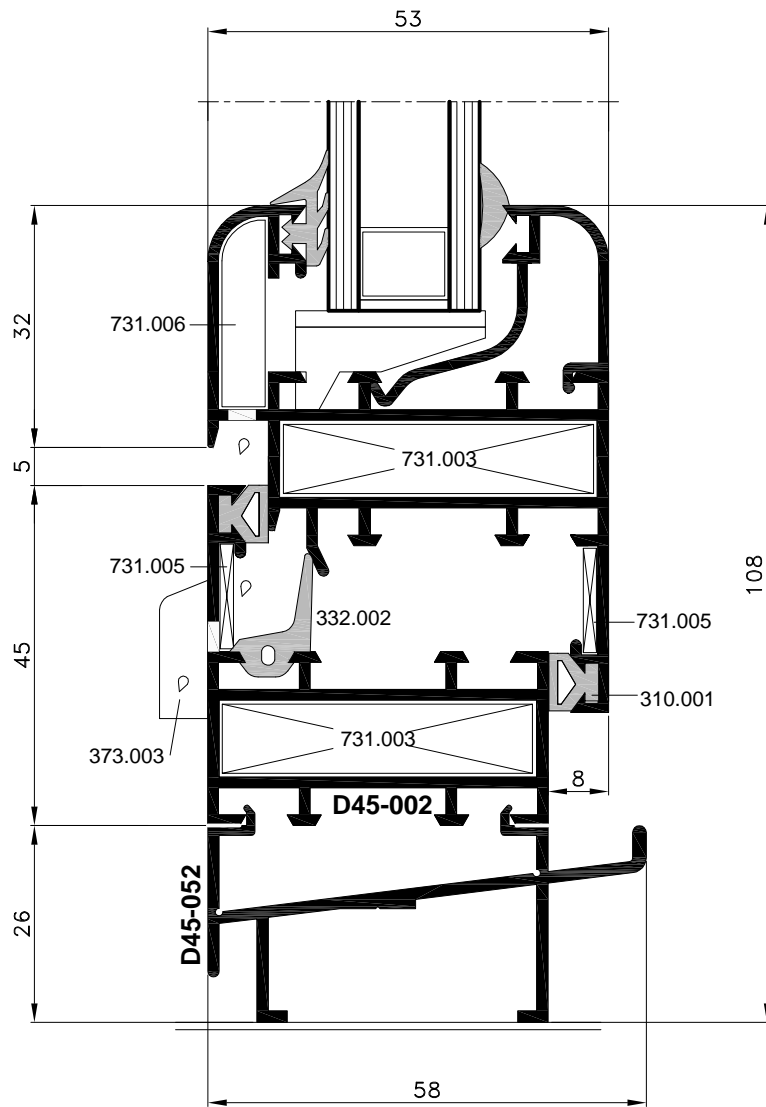
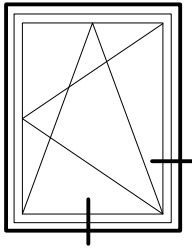

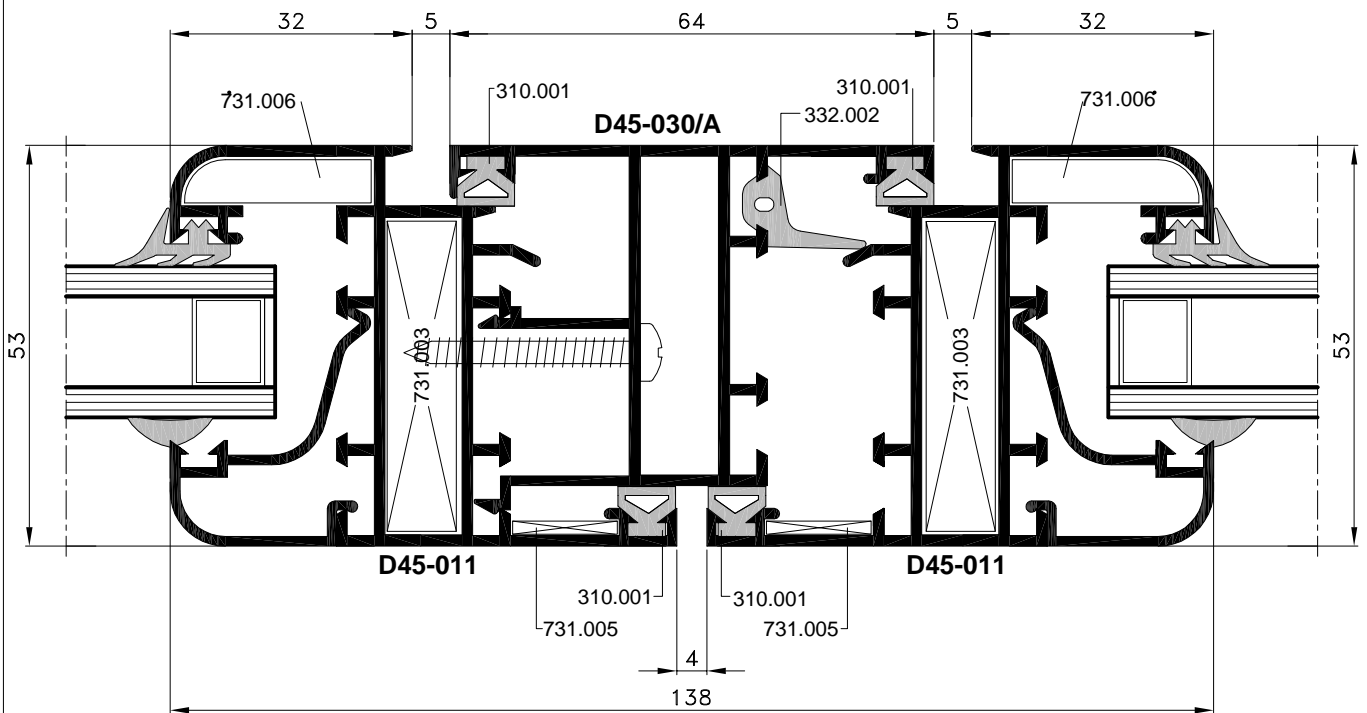
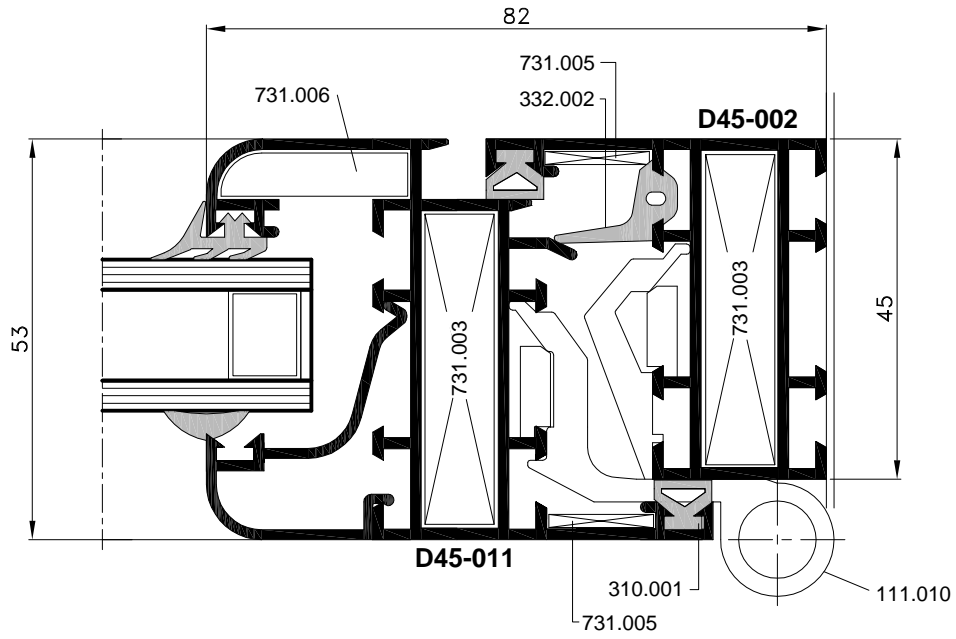
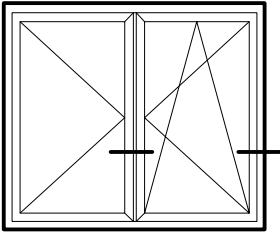

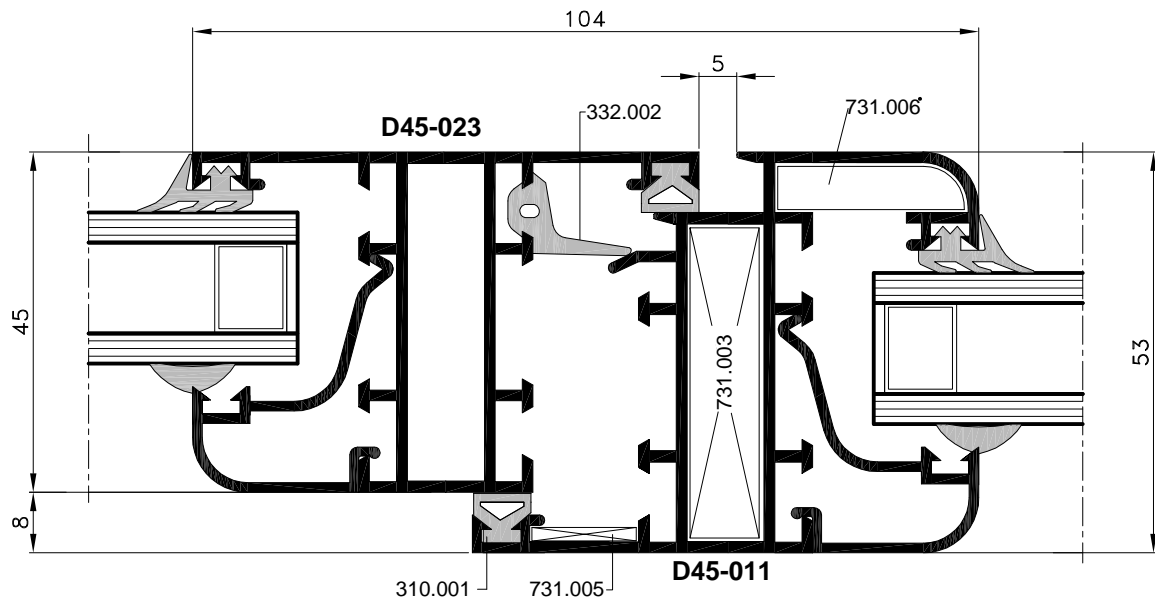
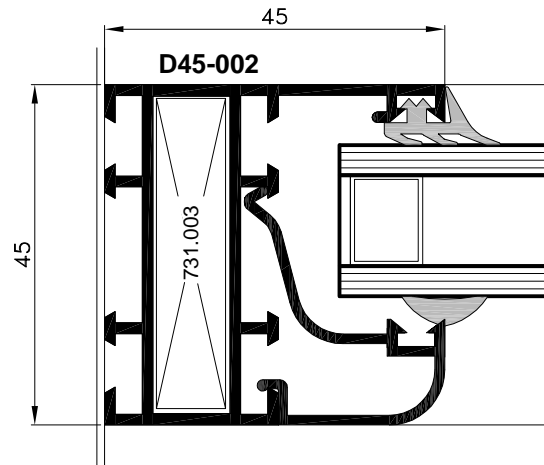
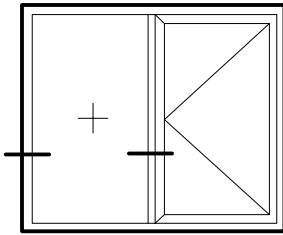

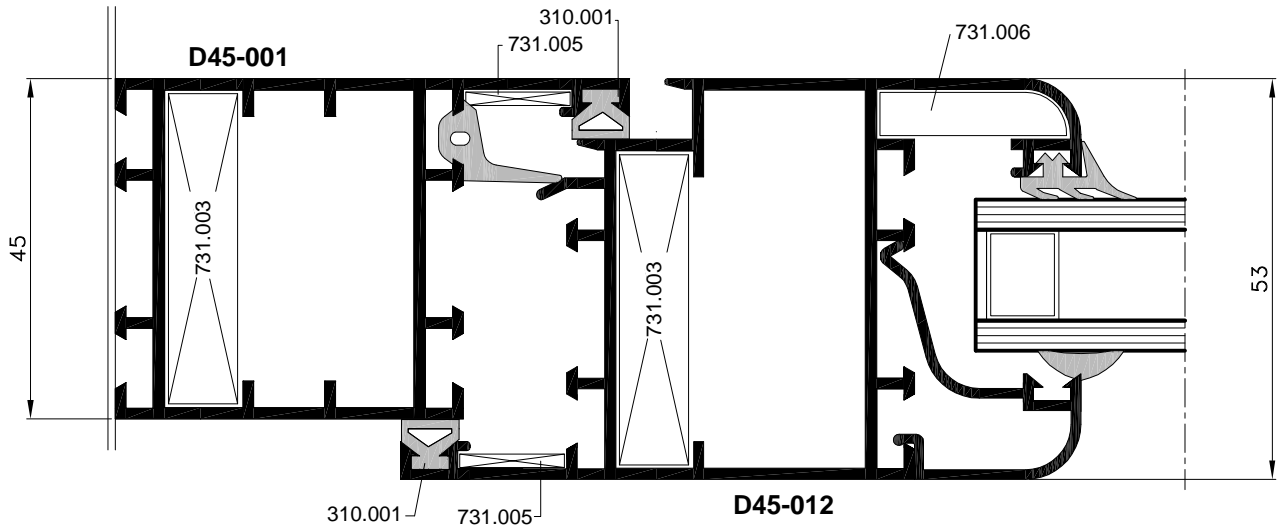
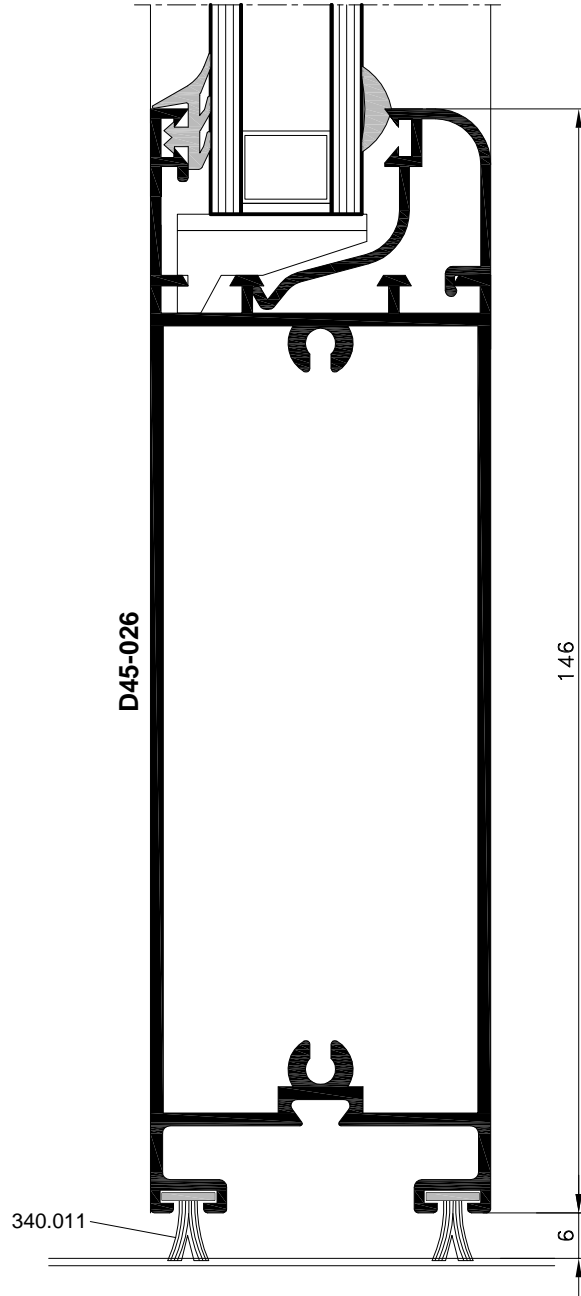
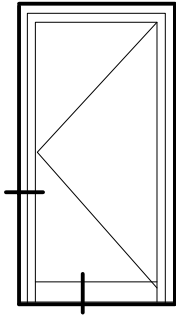

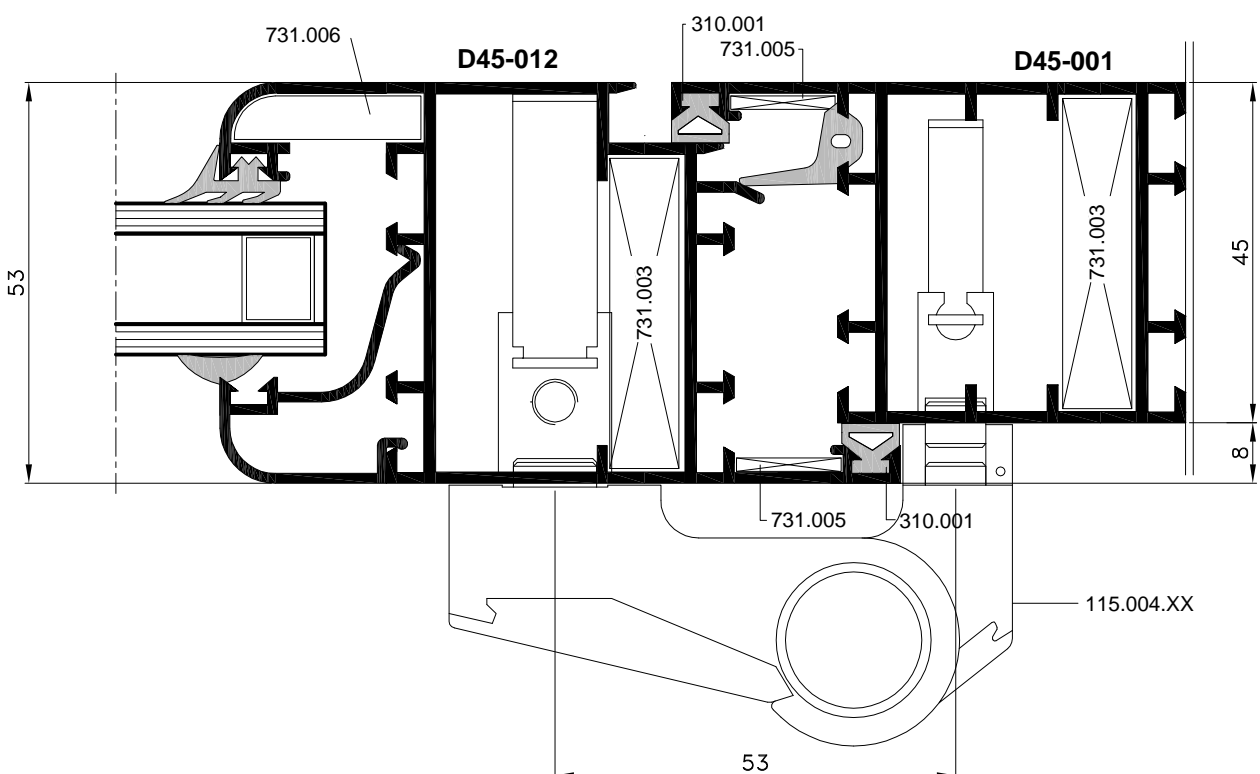
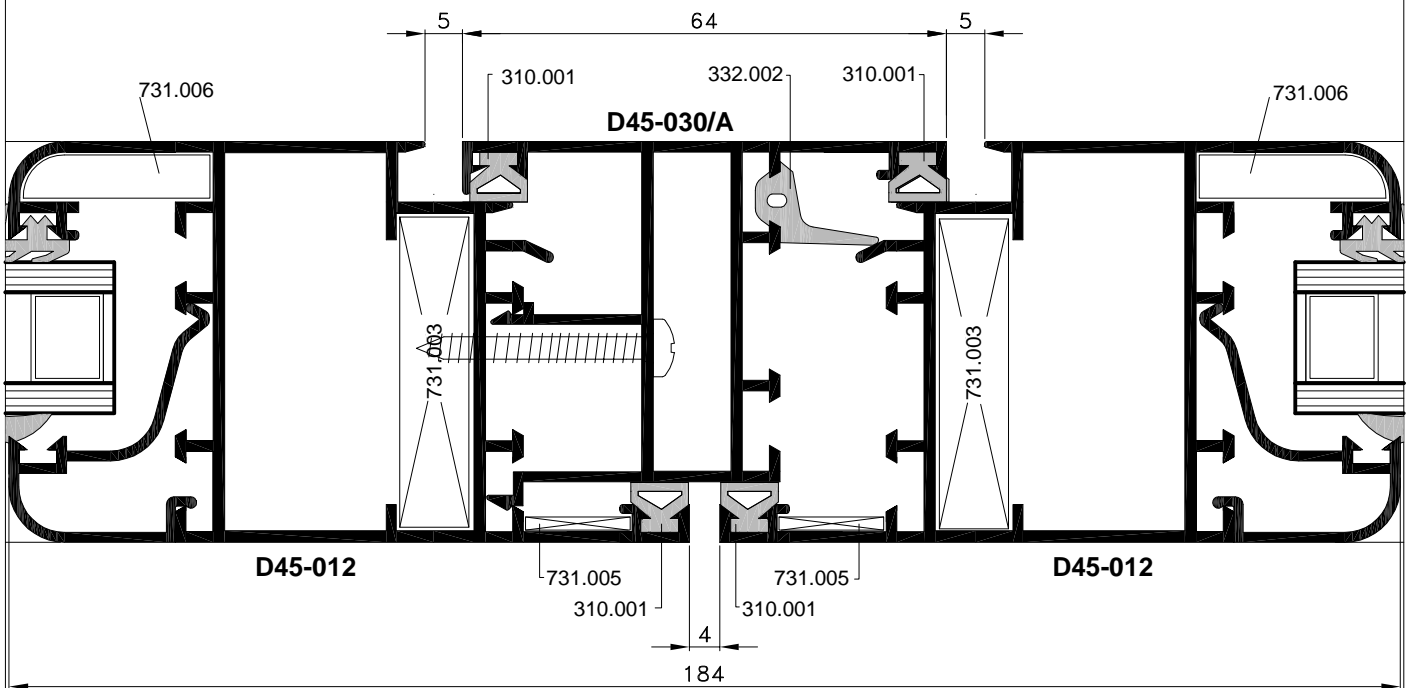
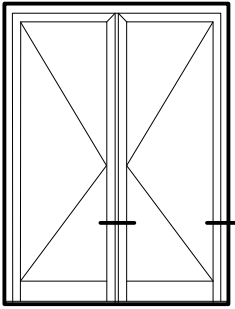

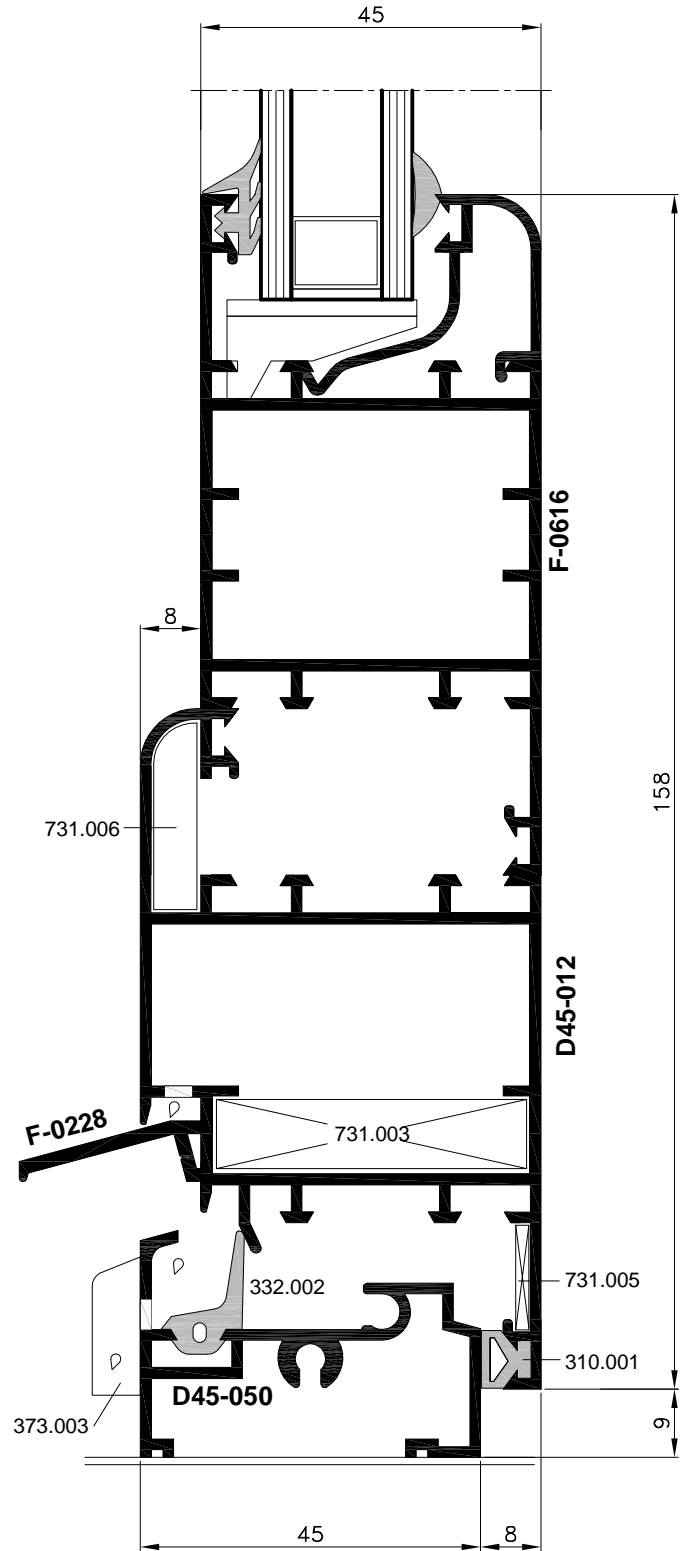
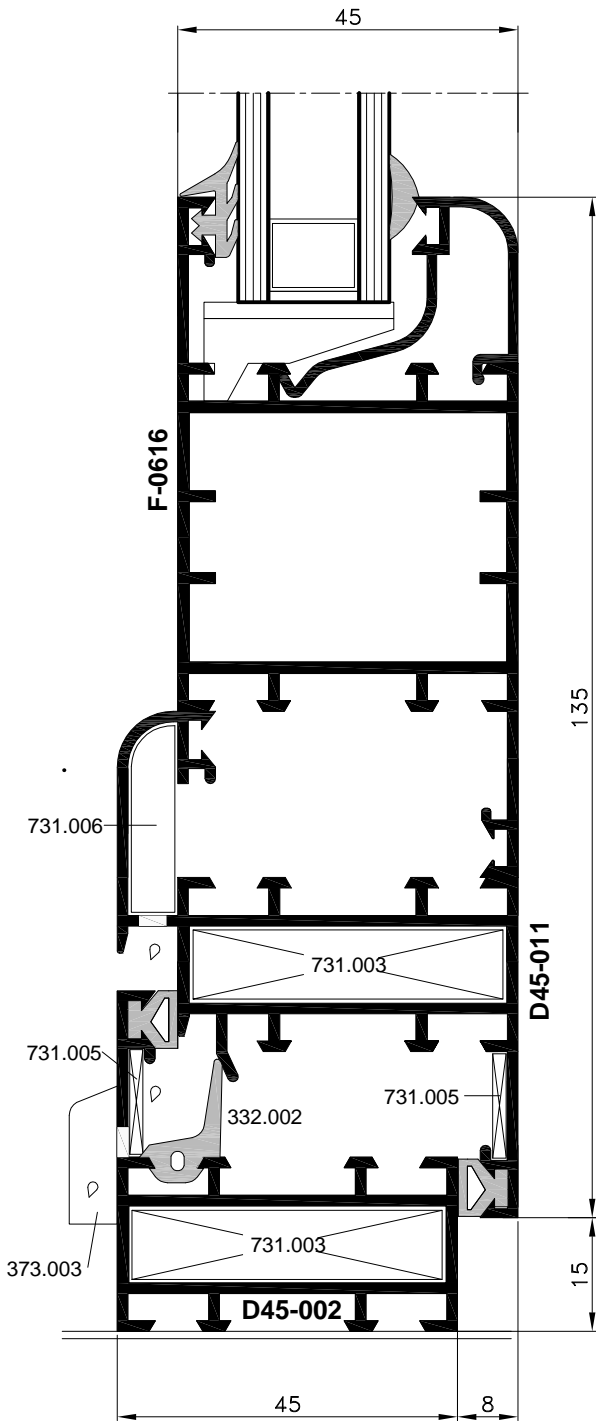
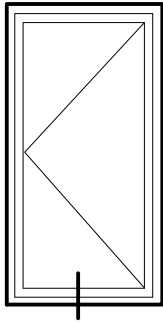

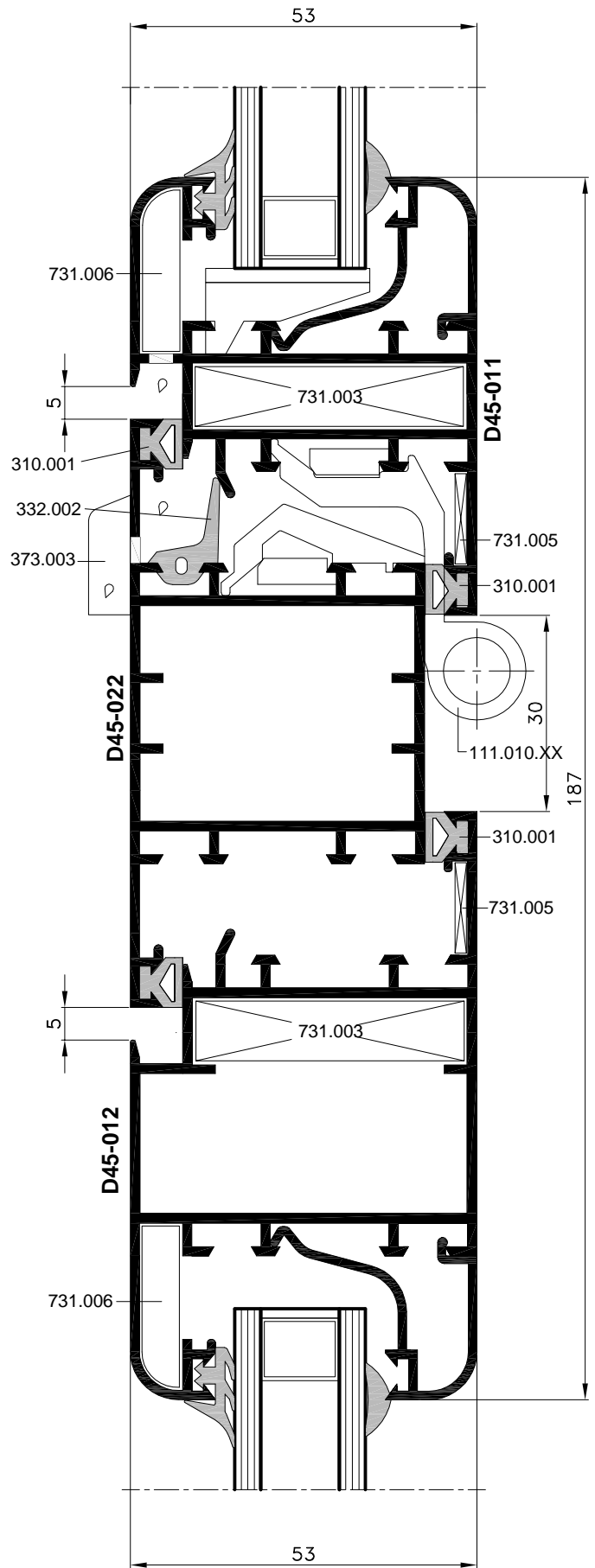
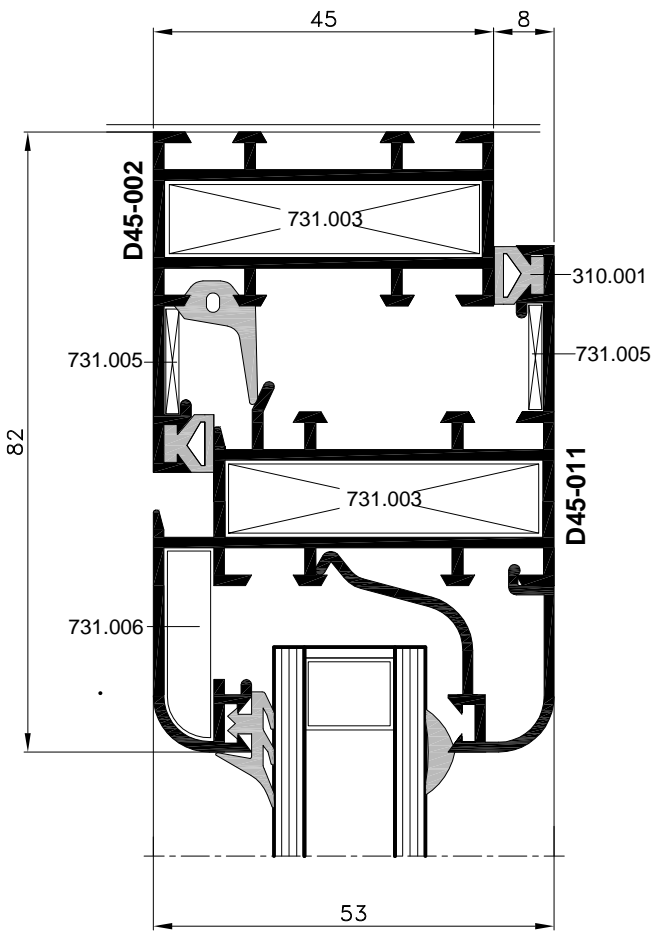
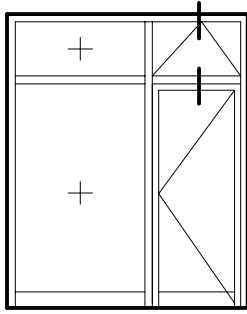

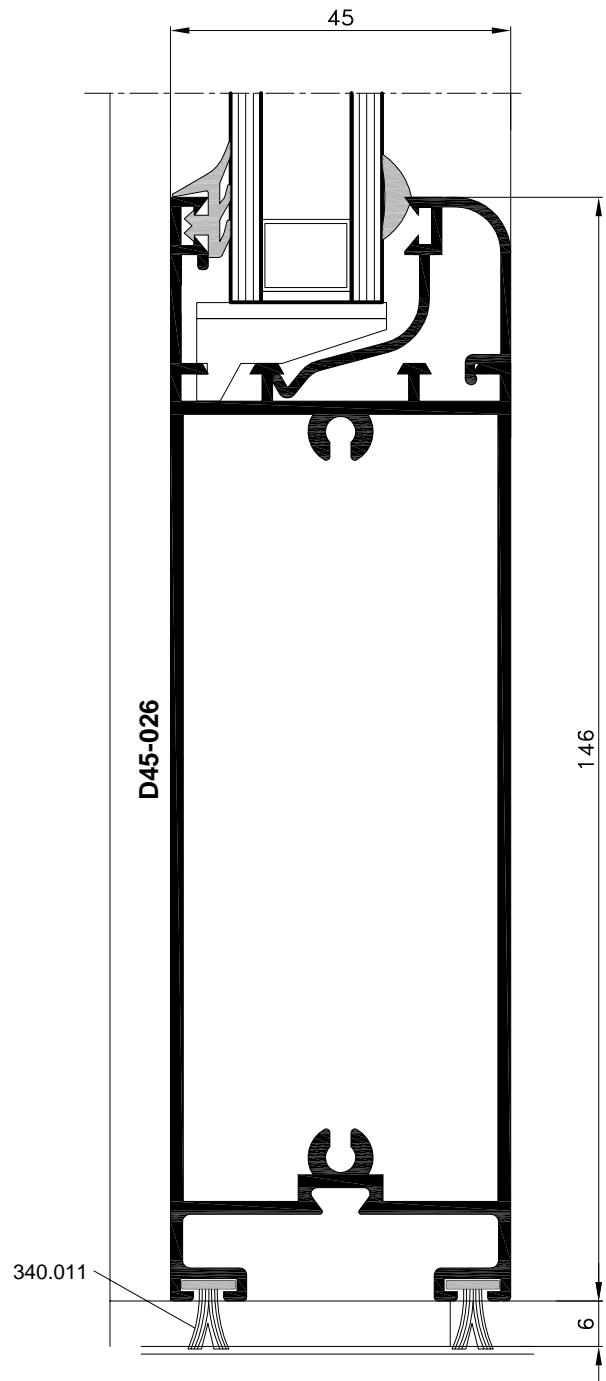
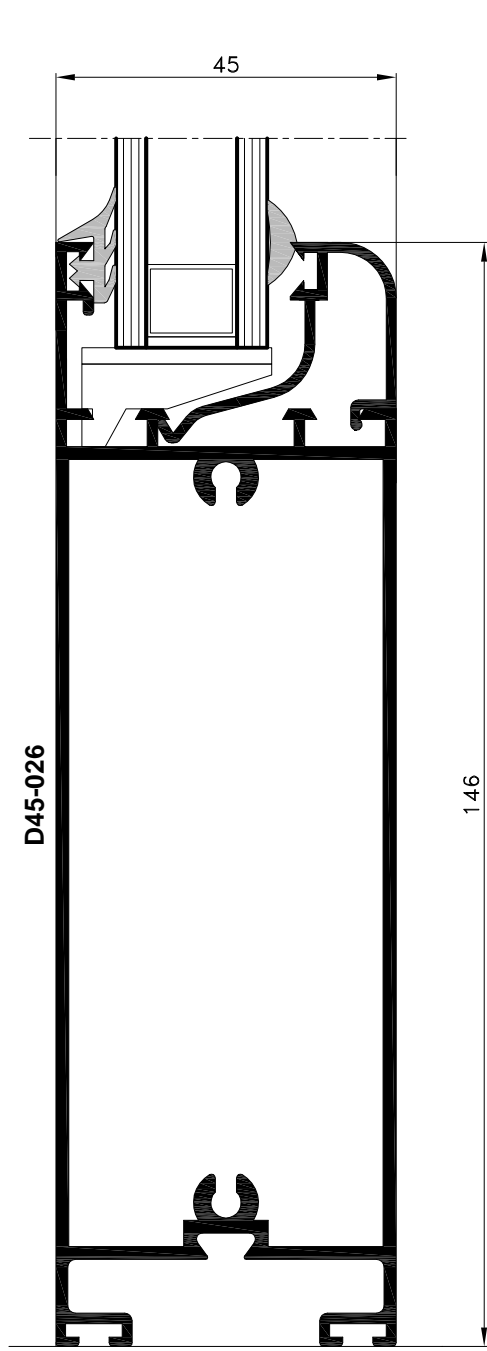
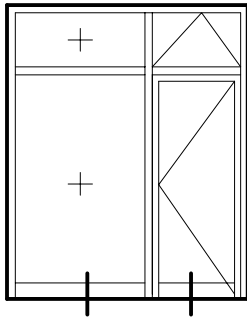

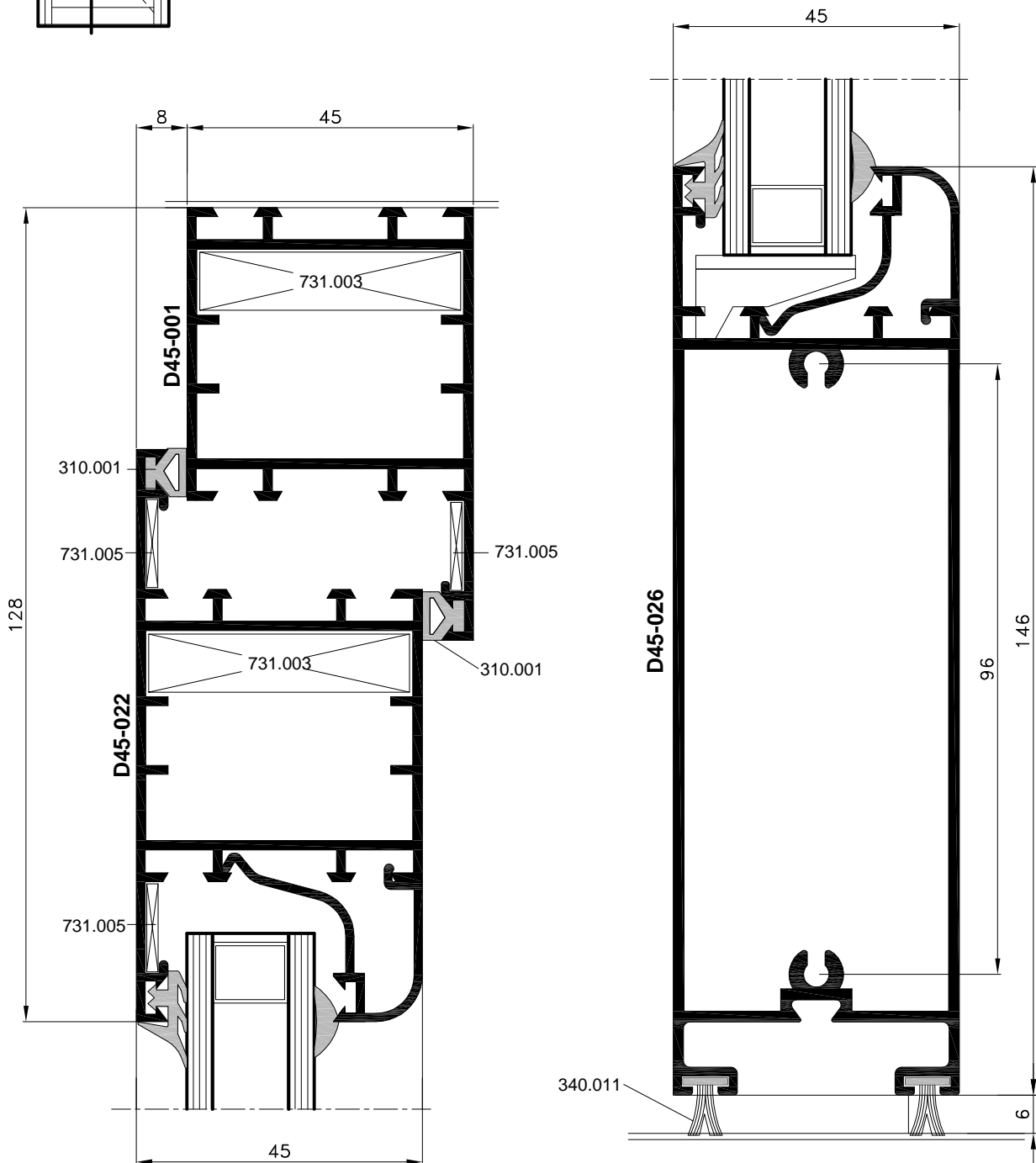
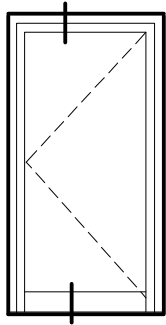

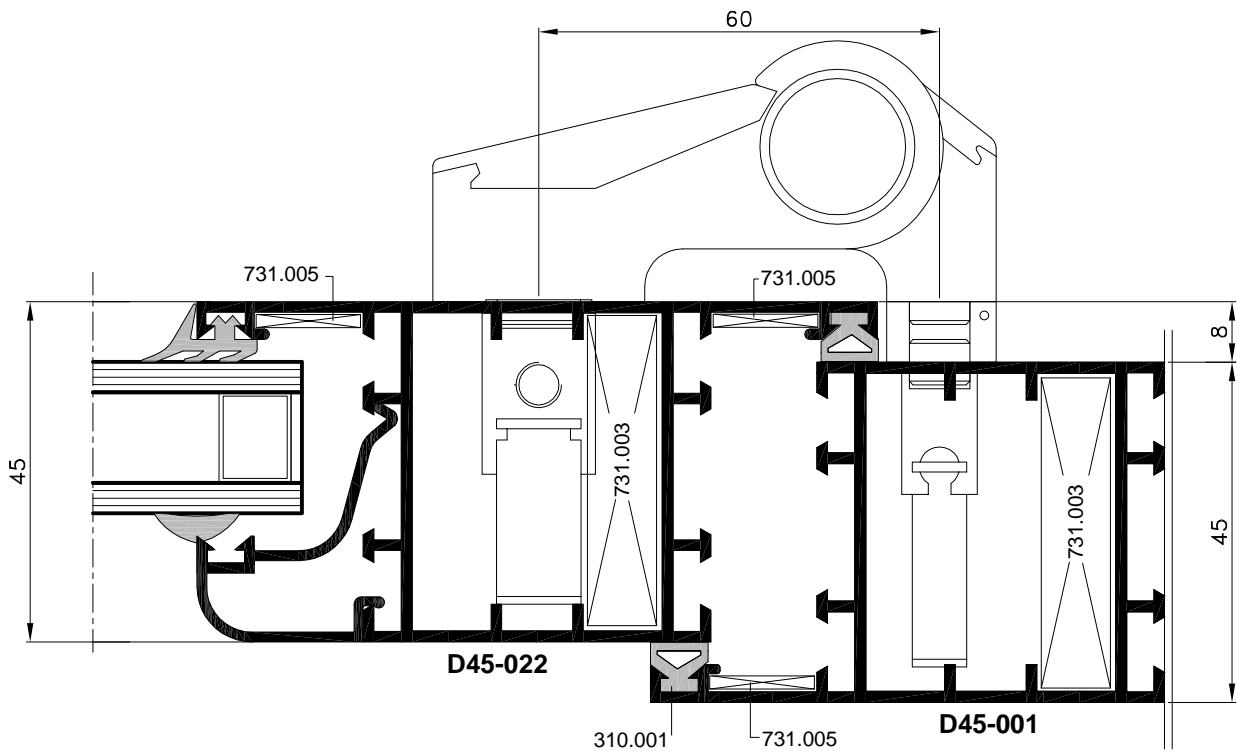
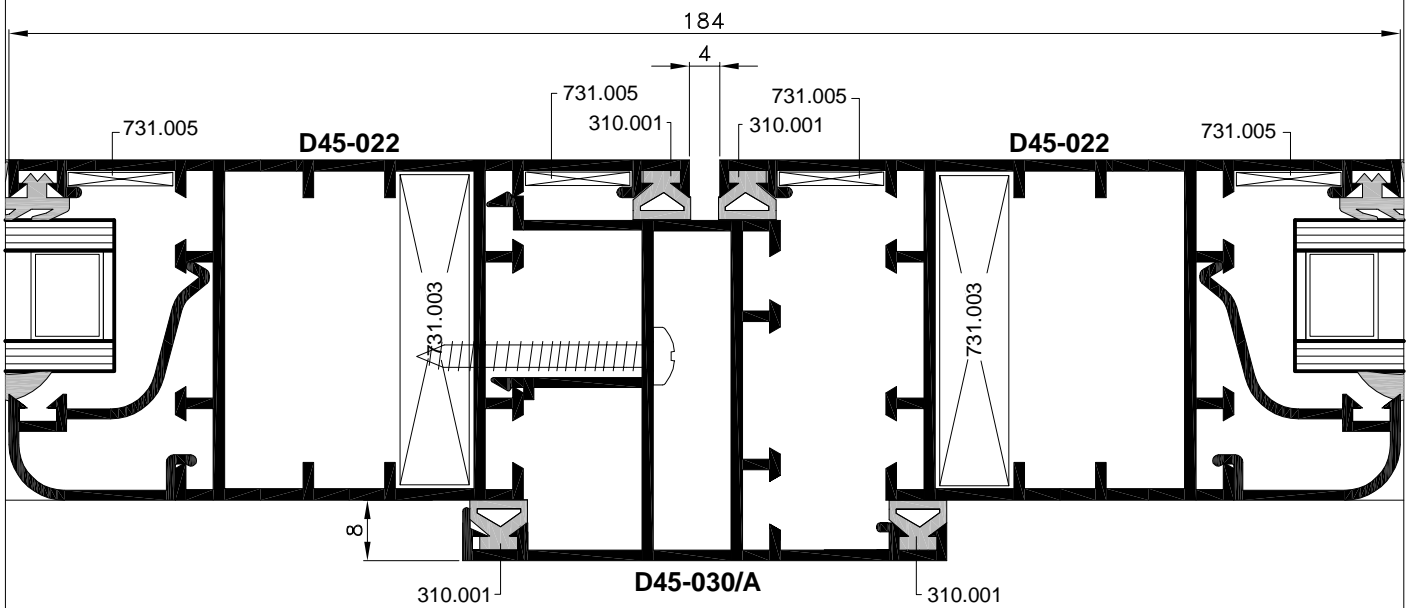
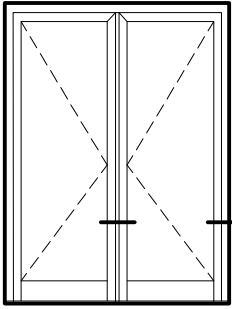

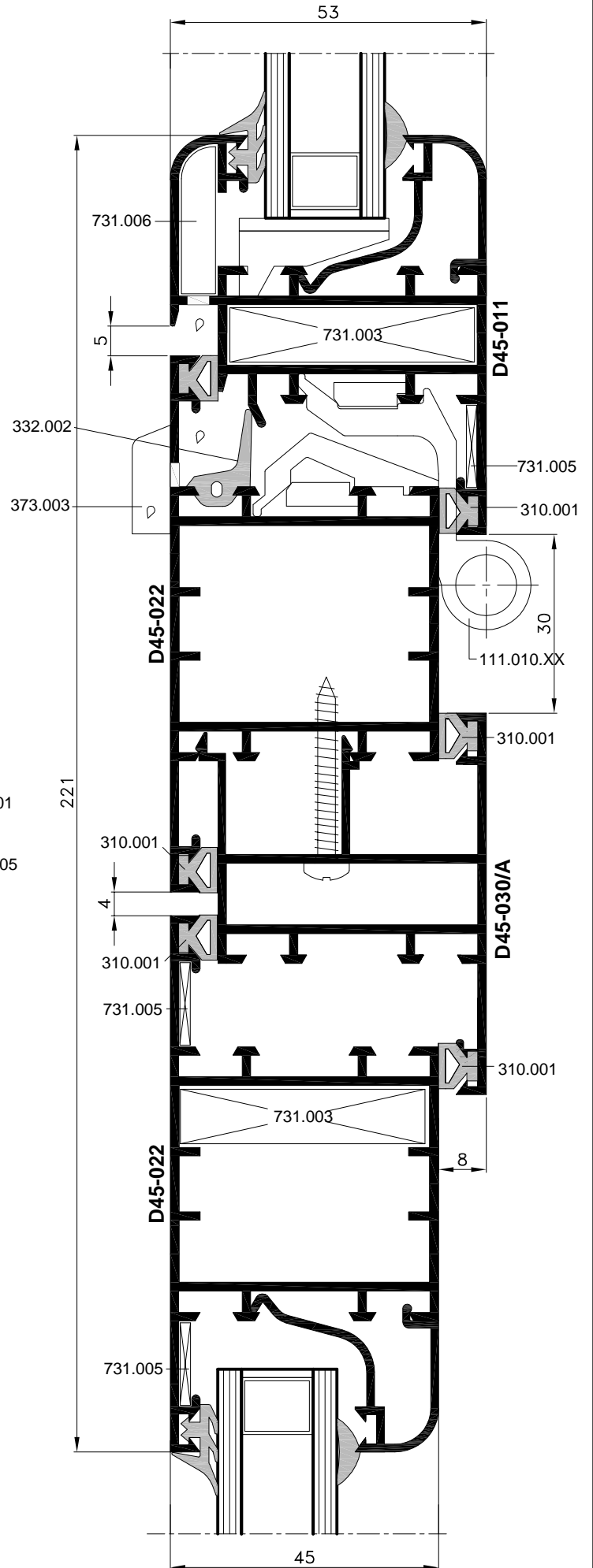
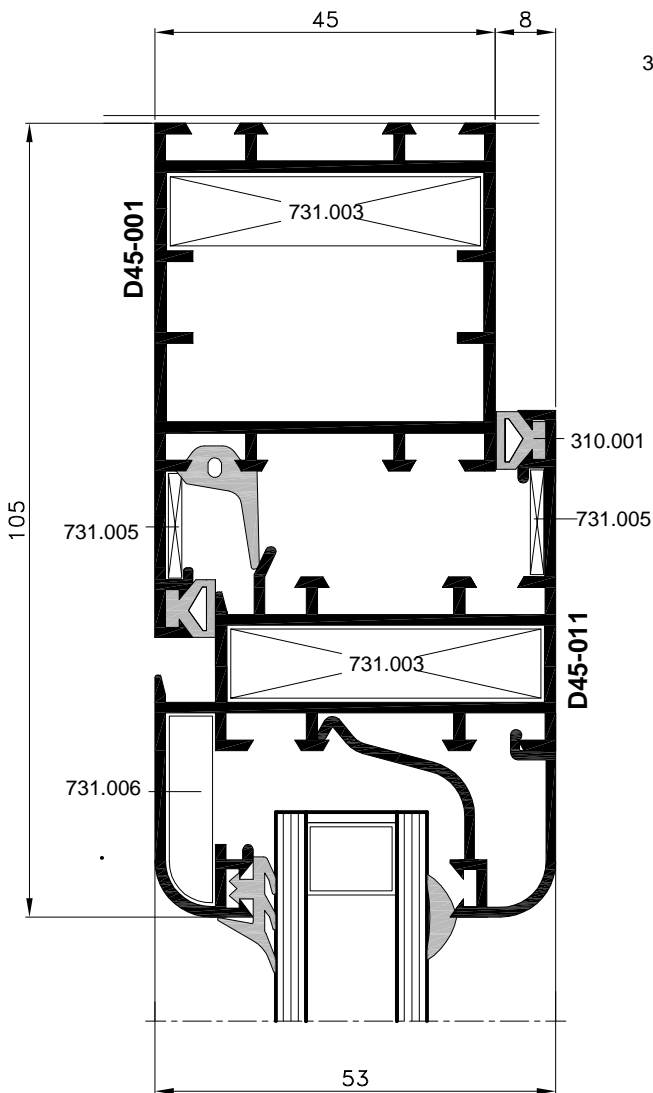
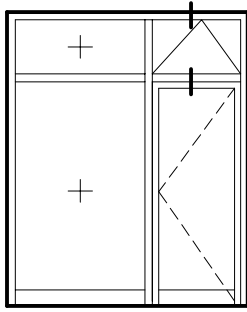

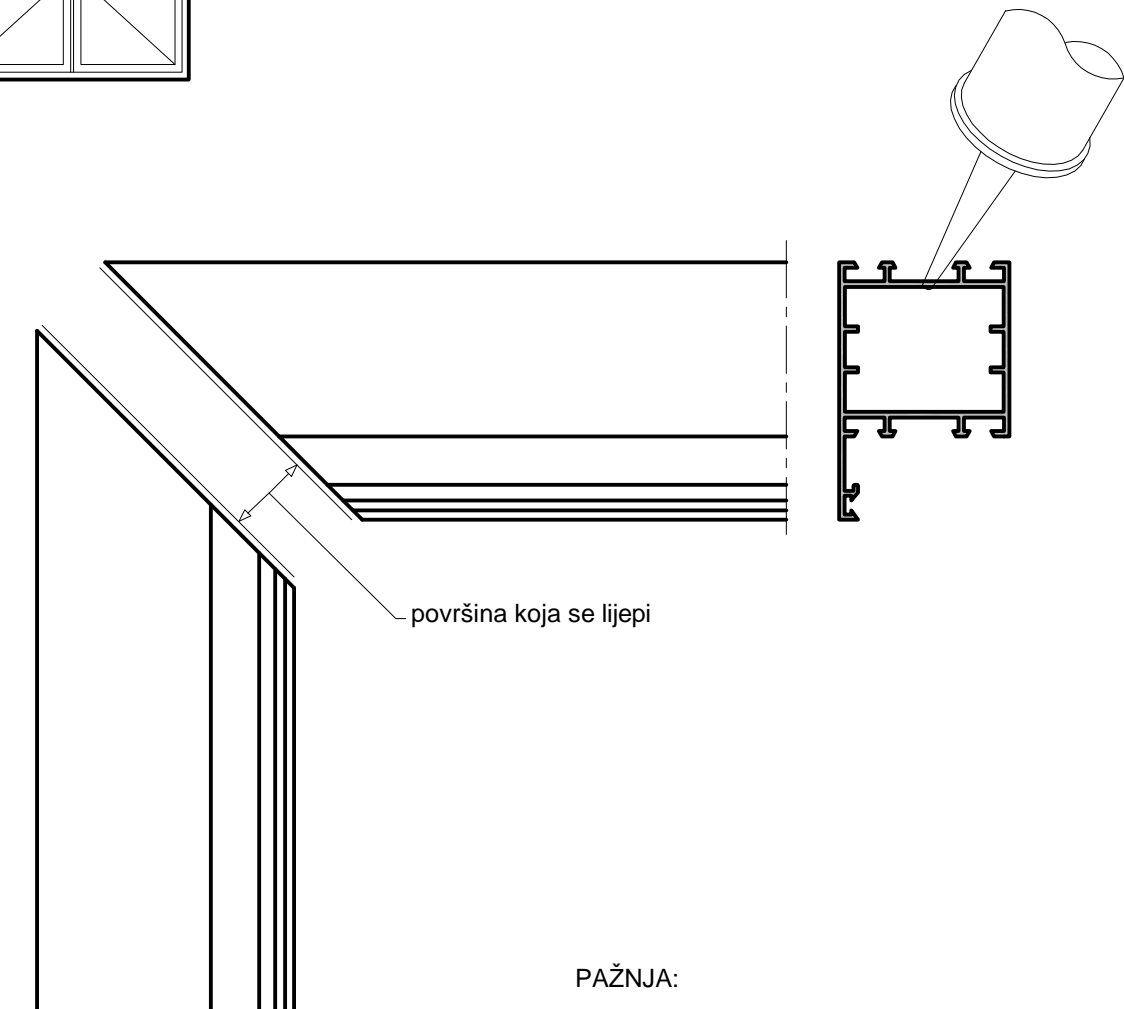
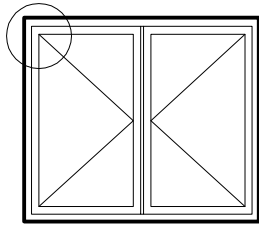

površina koja se lijepi

PAŽNJA:

Prilikom sklapanja-montaže profila na mjestima veze profila kutnikom, sve dodirne površine profila sa profilom kao i površine dodira profila sa kutnikom lijepiti i zapuniti dvokomponentnim kitom radi osiguranja zaptivenosti spoja.

